

METROLINK®



Southern California Regional Rail Authority

SCRRA CADD MANUAL

AUGUST 2016



Table of Contents

1.0	PRESENTATION AND DRAFTING GUIDELINES	1
1.1	POLICY	1
1.1.1	General.....	1
1.1.2	Purpose	1
1.1.3	Changes/Updates	1
1.1.4	Reference Standards	2
1.1.5	Acronyms.....	3
1.2	GENERAL DEFINITIONS	5
1.2.1	Addendum (Addenda).....	5
1.2.2	CADD.....	5
1.2.3	CAE	5
1.2.4	Change Order	5
1.2.5	Conformed Documents	5
1.2.6	Drawing Types	5
1.2.7	Electronic Data Files	7
1.2.8	Design Sketch.....	7
1.2.9	Design Consultant/Station Designers/General Engineering Consultant.	7
1.3	PROCEDURES	8
1.3.1	General Requirements	8
1.3.2	Original Documents.....	8
1.3.3	Drawing Preparation	8
1.3.4	Drawing Size.....	8
1.3.5	Drawing Orientation	8
1.3.6	Key Plans.....	9
1.3.7	North Arrows.....	9
1.3.8	Graphic Scales.....	10
1.3.9	Drawing Layout.....	11
1.3.10	Notes Layout.....	12
1.3.11	Match Lines.....	12
1.3.12	Prohibited Techniques	13
1.3.13	Sequence of Drawings in Contract Documents	13
1.4	DRAWING FORMAT	15
1.4.1	Cover Sheet.....	15
1.4.2	Title Sheet.....	15
1.4.3	Index of Drawings	15
1.4.4	Layout Index/Key Map	16
1.4.5	Abbreviation Sheet.....	17
1.4.6	Symbols Sheet.....	17
1.4.7	General Notes Sheet.....	17
1.4.8	Existing Topography Plans.....	17
1.4.9	Right-of-way.....	18
1.4.10	Civil Drawings	18
1.4.11	Utilities	27
1.4.12	Street Lighting and Traffic Signal Drawings.....	31
1.4.13	Trackwork	31



1.4.14	Geotechnical.....	32
1.4.15	Structural Drawings.....	32
1.4.16	Architectural Drawings.....	34
1.4.17	Illuminated Signs, Signage and Graphics.....	36
1.4.18	Landscaping.....	37
1.4.19	Signing and Pavement Marking.....	37
1.4.20	Mechanical Drawings.....	37
1.4.21	Electrical Drawings.....	38
1.4.22	Systems.....	40
1.5	DRAWING BORDER AND TITLE BLOCK	45
1.5.1	Abbreviations.....	45
1.5.2	Drawing Title Box.....	46
1.5.3	Contract Number Box.....	47
1.5.4	Drawing Number Box.....	47
1.5.5	Sheet Number Box.....	48
1.5.6	Revision Level Box.....	48
1.5.7	Scale Box.....	48
1.5.8	Design Engineering Consultant Box.....	49
1.5.9	Professional Seal Box.....	49
1.5.10	Design/Drawn/Checked/Approved Boxes.....	49
1.5.11	Date Box.....	50
1.5.12	Revision Block Box.....	50
1.5.13	Plot Stamp.....	51
1.6	SPECIFIC REQUIREMENTS.....	52
1.6.1	Linework.....	52
1.6.2	Lettering - General.....	52
1.6.3	Abbreviations.....	54
1.6.4	Graphic Symbols.....	55
1.6.5	Notes.....	55
1.6.6	Scales.....	55
1.6.7	Passenger Stations.....	62
1.6.8	Match Lines.....	62
1.6.9	Column Line Designations.....	62
1.7	DIMENSIONING.....	63
1.7.1	General.....	63
1.7.2	Location of Dimensions.....	64
1.7.3	Units of Measure.....	64
1.8	SECTION, DETAIL AND ELEVATIONS DESIGNATION.....	65
1.8.1	Sections.....	66
1.8.2	Details.....	67
1.8.3	Section, Details and Elevation Designation.....	68
1.8.4	Symbol Designation.....	68
1.8.5	Similar Sections.....	69
2.0	CADD GUIDELINES AND CRITERIA.....	70
2.1	PURPOSE.....	70
2.2	CADD QUALITY CONTROL.....	70



- 2.3 SOFTWARE 70
- 2.4 HARDWARE 71
- 2.5 DRAWING TYPES 71
- 2.6 FILE ORGANIZATION AND REQUIREMENTS 72
 - 2.6.1 Three Dimensional Files..... 72
 - 2.6.2 Contract Files..... 73
 - 2.6.3 Logicals..... 73
 - 2.6.4 Border File 73
 - 2.6.5 Seed Files..... 75
 - 2.6.6 Working Units..... 77
 - 2.6.7 Global Origins 77
 - 2.6.8 Structuring Project Files 78
- 2.7 FILE NAMING POLICIES 79
 - 2.7.1 General 79
 - 2.7.2 File Naming Procedures..... 80
 - 2.7.3 Contract Number..... 80
 - 2.7.4 Model File (Reference File) 80
 - 2.7.5 Xref (External References)..... 81
 - 2.7.6 Contract Drawing Files 81
- 2.8 DESIGN FILE NAMES 83
 - 2.8.1 Geographical and Non-Geographical Files..... 83
- 2.9 SPECIAL CONDITIONS 84
 - 2.9.1 Multiple Sub-Contracts 84
 - 2.9.2 Other Contract Reference Files..... 85
- 2.10 FILE EXTENSIONS 85
 - 2.10.1 Design Files 85
 - 2.10.2 Other than Design Files 85
- 2.11 LEVEL ASSIGNMENTS 86
 - 2.11.1 Definitions 87
 - 2.11.2 Categories 88
 - 2.11.3 Cell Library Names..... 89
 - 2.11.4 Cell Names 89
- 2.12 DIMENSIONING 89
 - 2.12.1 Dimension Style 90
- 2.13 TEXT 90
 - 2.13.1 General 90
 - 2.13.2 Justification 90
 - 2.13.3 Fonts..... 90
 - 2.13.4 Text Sizes 91
 - 2.13.5 Text Color 91
 - 2.13.6 Text Line Styles 91
 - 2.13.7 Enter Data Fields 91
- 2.14 ELEMENTS 91
 - 2.14.1 General 91
 - 2.14.2 Line Styles 92



- 2.14.3 Line Weights93
- 2.14.4 Color Table93
- 2.15 PATTERNING** 93
 - 2.15.1 Linear Patterning.....93
 - 2.15.2 Area Patterning.....93
- 2.16 SCREENING** 94
- 2.17 TERMINATORS**..... 94
 - 2.17.1 Line Terminators94
 - 2.17.2 Leader Lines94
 - 2.17.3 Pen Tables.....94
- 2.18 PLOTTING** 95
 - 2.18.1 Batch Plotting.....95
- 2.19 SUBMITTAL REQUIREMENTS** 95
 - 2.19.1 Guidelines.....95
 - 2.19.2 Checking Procedures.....95
- 2.20 CADD DATA IS A CONTRACT REQUIREMENT** 97
- 2.21 BACKUP AND ARCHIVING**..... 97
- 3.0 REVISION GUIDELINES AND CRITERIA** **98**
 - 3.0 REVISIONS** 98
 - 3.0.1 General98
 - 3.0.2 Applicability98
 - 3.0.3 Approvals.....98
 - 3.0.4 Revision Symbols98
 - 3.0.5 Revision Block100
 - 3.0.6 Revision Procedure.....101
 - 3.0.7 Issue and Revision Dates.....102
 - 3.0.8 Revision Descriptions.....102
 - 3.1 STANDARD AND DIRECTIVE DRAWINGS** 103
 - 3.1.1 Incorporating Standard & Directive Drawings Into Contract Drawings 103
 - 3.1.2 Changes to Standard and Directive Drawings103
 - 3.2 REVISIONS TO SEALED DOCUMENTS** 104
 - 3.2.1 Revisions by Others104
 - 3.2.2 Process.....104
 - 3.2.3 Revisions to a Standard Drawing104
 - 3.3 REFERENCE DRAWINGS**..... 104
 - 3.4 INSTALLATION DRAWINGS** 105
- 4.0 USER APPENDIX**..... **106**
 - APPENDIX 1 – ADDITIONAL DISCIPLINE CODE DESIGNATORS 107
 - APPENDIX 2 - SCALE FACTOR CHART (ENGLISH)..... 109
 - APPENDIX 3 - PEN TABLE DEFINITION (MICROSTATION)..... 110
 - APPENDIX 4 - LINE WEIGHTS TO PEN WIDTHS..... 116



APPENDIX 5 – SCRRA DISCIPLINE LEVELS..... 117

APPENDIX 6 - NATIONAL CADD STANDARD LEVEL NAMES..... 132

APPENDIX 7 – LINE WEIGHT PLOTTING CONFIGURATION 155

APPENDIX 8 – CUSTOM LINE STYLE (LC) SPECIFICATION 156

APPENDIX 9 – GRAPHIC SCALES 157

APPENDIX 10 – SAMPLE SCRRA BORDER AND TITLE BLOCK..... 158

APPENDIX 11 – SAMPLE SCRRA BORDER AND TITLE BLOCK 159

APPENDIX 12 – SAMPLE INDEX OF DRAWINGS 160

APPENDIX 13 – SAMPLE INDEX OF DRAWINGS 161

APPENDIX 14 – SAMPLE PLAN AND PROFILE 162

APPENDIX 15 – SAMPLE PLAN AND PROFILE 163

APPENDIX 16 – SAMPLE PLAN AND PROFILE 164

APPENDIX 17 – SAMPLE FULL PROFILE 165

APPENDIX 18 – SAMPLE TITLE PAGE 166



1.0 PRESENTATION AND DRAFTING GUIDELINES

1.1 POLICY

1.1.1 General

It is the policy of the Southern California Regional Rail Authority (SCRRA) that all drawings developed for the Metrolink Stations, Track and Facilities Construction Contracts shall be in Computer Aided Design and Drafting (CADD) format and comply with uniform standards for presentation, planning, drafting, and revising drawings.

These presentation drafting guidelines, CADD guidelines, and revision guidelines are prepared exclusively for and shall apply to all work performed by consultants, SCRRA in-house designers sub-consultants and contractors providing CADD deliverables to SCRRA. They shall, in addition, apply to any other work so designated by SCRRA, unless the SCRRA Director of Engineering and Construction specifically provides in these standards, or in writing, an exemption. These standards shall apply to all contract drawing documents.

Managers, engineers, architects, CADD users, technicians, and designers are responsible for adhering to the criteria as presented in this manual.

1.1.2 Purpose

The purpose of this manual is to provide consultants, sub-consultants and contractors with the SCRRA requirements to produce a set of architectural/engineering construction drawings that are immediately recognizable and legible. The individual drawings shall be clean and neatly organized. They shall contain sufficient information to clearly indicate the design intent, without being cluttered. Clarity of intent shall be enhanced by the use of a consistent graphical presentation. Related information shall be grouped together in the drawing set and be adequately cross-referenced. Standard drawing items such as north arrows, notes, and titles shall be placed in the same location on each drawing. Consistency of “style” shall be evident across disciplines and throughout the entire drawing set. The drawings should have the same general appearance without reflection on individual style.

The purpose is to establish uniform presentation standards and criteria for drafting, drawing size, title block, etc., for all project drawings produced by consultants, sub-consultants and contractors providing CADD deliverables to SCRRA.

1.1.3 Changes/Updates

The most recent date shown in the lower right hand footer of each page is the effective date of this Manual. The most recent effective date shall supersede all previous versions. Revisions and updates to the Manual will be posted on the Metrolink website www.metrolinktrains.com. Users of this Manual shall be solely responsible for checking the website and utilizing the latest version.

Those individuals who regularly use this Manual can provide valuable assistance in identifying needed updates and improvements. Forward any suggested changes or suggestions to this Manual to the Assistant Director, Standards and Design for



consideration. Suggested changes or suggestions should be submitted in writing by completing **SCRRA Form DPM-32: DPM Manual Comments Form**. Each suggested change will be reviewed and responded to by a committee of SCRRA managers shown on **SCRRA Form DPM-13: Request for Special Design Consideration Form**. If SCRRA committee agrees with the suggested change, the Manual will be updated to reflect the change in the next revision. Corrections of any typographical errors contained herein that do not materially and significantly affect criteria will not require approval by the SCRRA committee. **The current effective date of these Guidelines shall be August 2016.**

1.1.4 Reference Standards

The following is a general listing of specific design criteria, which shall be adhered to. This list is by no means comprehensive and other standards may apply.

The design shall meet all applicable parts of the State of California general laws, California Public Utilities Commission (CPUC) requirements, FRA safety requirements, and the specific project requirements. Where any conflict in criteria exists, the stricter criteria shall govern.

Unless specifically noted otherwise in these criteria, the latest edition of the standard, code, or guideline that is applicable at the time the design is initiated shall be used. If a new edition of or amendment to a standard, code, or guideline is issued before the design is completed, the design shall conform to the new requirements to the extent approved or required by the agency enforcing the standard, code, or guideline changed.

Industry Standards

The most recent editions of the following publications and documents were used:

- A. AASHTO - American Association of State Highway and Transportation Officials
- B. ADA - Americans with Disabilities Act
- C. AREMA - American Railway Engineering and Maintenance-of-Way Association (AREMA) Recommended Practice
- D. Cal/OSHA - State of California Division of Occupational Safety and Health safety orders
- E. Caltrans - Caltrans Highway Design Manual (HDM)
- F. CBC - California Building Code
- G. CPUC - California Public Utilities Commission General Orders
- H. FRA - Federal Railroad Administration, Track Safety Standards, particularly 49 Code of Federal Regulations (CFR) 213, 214, 234, and 236
- I. FTA - Federal Transit Administration, Federal Highway Administration (FHWA)
- J. "Greenbook" Standard Specifications for Public Works Construction, written and promulgated by Public Works Standards, Inc.
- K. Government Codes of the State of California
- L. UBC - Uniform Building Code, including seismic requirements
- M. 49 CFR 195, Transportation of Hazardous Liquids by Pipeline



SCRRA Standards

SCRRA has developed a number of standard plans, specifications, and manuals that shall be applied to this project. In particular, standard plans and specifications shall be used wherever possible to reduce engineering and construction costs. All standards and manuals shall be adhered to throughout this project unless waived in writing by SCRRA Director of Engineering and Construction.

- A. SCRRA Engineering Standards
- B. SCRRA Standard Specifications
- C. SCRRA Design Criteria Manual
- D. SCRRA Design Procedures Manual
- E. SCRRA Design Quality Assurance Manual
- F. SCRRA CADD Standards
- G. SCRRA Track Maintenance, Right-of-Way and Structures Engineering Instructions
- H. Standard Operating Procedures (SOPs)

SCRRA Guidelines

The following SCRRA documents will also be referenced and revised as appropriate:

- A. SCRRA Highway-Rail Grade Crossings Recommended Design Practices and Standards Manual
- B. Grade Separation Guidelines
- C. Excavation Support Guidelines
- D. Landscape Design Guidelines
- E. Rails-with-trails Design Guidelines
- F. Quiet Zone Implementation Guidelines and Procedures
- G. SCRRA Temporary Traffic Control Guidelines

SCRRA Design Procedures Manual

The overall design process will follow the steps defined in the SCRRA Design Procedures Manual, which defines the required submittals, deliverables, and reviews. The manual also defines the development of specifications and estimates. As previously noted, the design shall incorporate existing SCRRA standards, plans, and specifications.

1.1.5 Acronyms

The following acronyms are used in this Manual:

ACI	American Concrete Institute
AIA	American Institute of Architects
AISC	American Institute of Steel Construction
ANSI	American National Standards Institute
APWA	American Public Works Association
AREMA	American Railway Engineering and Maintenance of



	Way Association
ASHRAE	American Society of Heating, Refrigerating, and Air Conditioning Engineers
ASME	American Society of Mechanical Engineers
ASTM	American Society for Testing and Materials
ATP	Automatic Train Protection
ATO	Automatic Train Operations
ATS	Automatic Train Supervision
BNSF	Burlington Northern & Santa Fe Railway
Caltrans	California Department of Transportation
C&S	Communications and Signals
CADD	Computer-Aided Drafting and Design
CAE	Computer Assisted Engineering
CFR	Code of Federal Regulations
CPUC	California Public Utilities Commission
CTO	Contract Task Order
DOC	Dispatch and Operations Center
FCC	Federal Communication Commission
FRA	Federal Railway Administration
GEC	General Engineering Consultant
IEEE	Institute of Electrical and Electronic Engineers
IFB	Invitation for Bids
METRO	Los Angeles County Metropolitan Transportation Authority
MOC	Metrolink Operations Center
MSF	Melbourne Maintenance Support Facility
NAD	North American Datum
NAVD	North American Vertical Datum
NCTD	North County Transit District
NEC	National Electrical Code
NIS	Not In Contract
NTS	Not to Scale
OCTA	Orange County Transportation Authority
OSHA	Occupational Safety and Health Administration
PE	Preliminary Engineering
PTC	Positive Train Control
RCTC	Riverside County Transportation Commission
ROW	Right-of-Way
SANBAG	San Bernardino Associated Governments
SCRRA	Southern California Regional Rail Authority
SSPWC	Standard Specifications & Plans for Public Works Construction
UP	Union Pacific Railroad
USA	Underground Service Alert
VCTC	Ventura County Transportation Commission



1.2 GENERAL DEFINITIONS

1.2.1 Addendum (Addenda)

Written or graphic instrument(s) issued during the bidding period to modify or interpret the bidding documents, including drawings and specifications. Modifications may include additions, deletions, clarifications, or corrections. Addenda involving drawings may be executed by written description only or include reissue of modified or new drawings. Addenda become part of the contract documents when the construction contract is executed.

1.2.2 CADD

Computer Aided Design and Drafting used in the design and production of contract drawings. Within the Context of this document, CAD and CADD are equivalent terms.

The SCRRA accepted CADD software shall be Microstation V8i (or latest) a registered trademark of Bentley Systems, Inc.

It is recommended to use only one software platform per project. However, if a different case arises, the consultant should get appropriate approval from SCRRA and will become responsible for any translation.

1.2.3 CAE

Computer Assisted Engineering.

1.2.4 Change Order

Documents issued to the contractor by the SCRRA to modify the contract.

1.2.5 Conformed Documents

Documents that have been modified to incorporate all issued changes. Construction/procurement documents are generally conformed following award to incorporate all addenda, issued during the bid period.

1.2.6 Drawing Types

A. Approved Drawing

A drawing that has been reviewed and approved for issue by General Engineering Consultant (GEC) and its sub-consultant or joint venture home office, and whose content has been approved by SCRRA.

B. Baseline Drawing

A final camera-ready drawing approved by SCRRA fully prepared and submitted for initial issue at the contract advertising period.

C. Conceptual Drawing

A drawing originated to clarify concepts and use for reference and studies. All conceptual drawings will be assigned preliminary engineering numbers. If the



conceptual drawings become the basis for final design, all approval blocks must be completed and a place for SCRRA approval shall be provided.

D. Contract Drawing

A drawing included in bid and awarded contract package. Used in this section to include any drawing behind a drawing package cover sheet.

E. Controlled Drawing

Those drawings for which a formalized change process for revisions/updates after initial issue is required.

F. Detail Drawing

A drawing that illustrates the design in greater detail and will also become a part of a construction or procurement contract. As such, application of these procedures is mandatory. Examples include:

1. Architectural Details
2. Fencing Details
3. Structural Details
4. Isometric

G. General Drawing

A drawing that is part of a construction or procurement contract. As such, application of these procedures is mandatory.

H. Preliminary Engineering (PE) Drawing

A drawing that results from the conceptual phase and will serve as a basis for the development of final design drawings. These drawings reflect approximately 30% of the overall design completion. The information contained in these drawings is considered preliminary and is provided for further refinement. All information contained in these drawings must be verified during the final design prior to inclusion into construction documents.

I. In-Progress, Pre-Final and Final Drawing

Drawings submitted for In Progress (60%), Pre-Final (90%) and Final (100%) design review. The level of completion shall be as defined in the contract.

J. Project Record / As-Built Drawing

Drawings that have been modified to accurately reflect as-built conditions. These drawings incorporate all changes made during the construction phase of the work. These drawings are prepared in accordance with as-built records provided by the contractor and resident engineer. Any drawing that is prepared by modifying the original contract documents and are subsequently stamped "As-Built" or "Record" and dated. All such changes shall be incorporated in to the final CAD files.



K. Reference Drawing

A drawing from another contract or prepared by an outside source, which is included in a contract package for reference use only, and is marked “FOR REFERENCE ONLY, NOT FOR CONSTRUCTION”. Reference drawings are not required to comply with these procedures. Reference drawings in this context do not refer to CADD reference files.

L. Shop Drawing

Detail drawings showing individual items/components that are utilized and prepared by the fabricator to be used in the assembly of the specific item or structure.

M. Standard Drawing

A drawing that has been developed by SCRRA or under SCRRA’s direction shall be used as a contract drawing without modification. Use of Standard drawings are for repetitive items in order to obtain uniformity in materials, geometrics, arrangements, details and procedures, and in some instances, such as for utilities, to express prior approval of interested agencies. The applicability of any item shown on a Standard Drawing included in the project drawings shall be determined by the design consultant through reference on the project drawings and by the requirements of the Specifications. All Standard Drawings applicable to the contract work shall be included in the project drawings and/or specifications. Copying of standard items shall be avoided. Items not applicable in a particular contract shall be crossed out or indicated that they are not in the contract; these drawings are to be interpreted in a similar manner as would be done for Standard Specifications. A Standard Drawing shall remain identified in the title block as STANDARD and by the title of the subject matter.

1.2.7 Electronic Data Files

All data files produced in CADD design, including supporting files such as resource files, plot files, and translation files needed to produce contract drawings.

1.2.8 Design Sketch

Sketches are used to illustrate design concepts or to clarify a design intent. These are generally freehand or rough drafted studies. Where a more precise drawing is required for analysis, electronic drafting should be used since this provides the basis for further CADD development. Design sketches retained for record should include names of originator (and drafter if different) and reviewer name, disposition comments and dates. Conceptual Design expressed on sketches (manual or digital) does not need to follow any CADD Standards, unless its purpose is to be reused for construction document phase.

1.2.9 Design Consultant/Station Designers/General Engineering Consultant

Any group, including joint venture members, under contract to SCRRA with a defined scope of services to design a portion of the project or to provide a service to the SCRRA.



1.3 PROCEDURES

1.3.1 General Requirements

Drawings must be accurate in scale and match shown dimensions, be consistent one part with another, and consistent with all design criteria, specifications, and standard and directive drawings. Drafting techniques should be consistent throughout all discipline drawings of a contract set. Drawings will be reduced to half-size 11"x17" and, therefore, appropriate drafting techniques shall be used to ensure legibility and accuracy.

1.3.2 Original Documents

All original controlled documents and their associated CADD files shall be placed in the custody of SCRRA upon completion of the design and/or construction.

1.3.3 Drawing Preparation

- A. In addition to title sheets, there are four basic types of drawings. They are;
 - 1. Index Sheets
 - 2. Plan and Profile drawings
 - 3. Full grid/cross section/detail drawings
 - 4. Schedule drawings (i.e., Panel, Conduit, Finish, Door, etc)
- B. Some drawings may be prepared with a screened background for clarification
- C. Design and detail drawings shall be prepared using the standard drawing sheet format.
- D. Drawings prepared for other public agencies (such as CPUC) and approved by SCRRA for use and will conform to the medium supplied and required by the particular agency.

1.3.4 Drawing Size

- A. The standard drawing size for all SCRRA contract drawings shall be 22"x34" (ANSI Standard Size D) unless other conditions are specified. PDF files shall be provided in both 22"x34" and 11"x17" format.
- B. Exceptions to the standard drawing size requirement may be allowed in the following case;
 - 1. Drawings prepared on media furnished by other public agencies and included in contract documents distributed by those agencies.
 - 2. Drawings prepared for presentations, exhibits, conceptual design and other graphics not part of construction documents.

1.3.5 Drawing Orientation

All plans in a project depicting the same work area shall have the same scale, orientation and match lines. Drawings shall be oriented to allow increasing stationing to proceed



from the left to the right. All plans on a sheet shall have the same orientation where possible. Refer to [Figure 1.0](#).

All drawings, associated text and dimensions shall refer to [Section 1.7](#) and [Section 2.12](#)

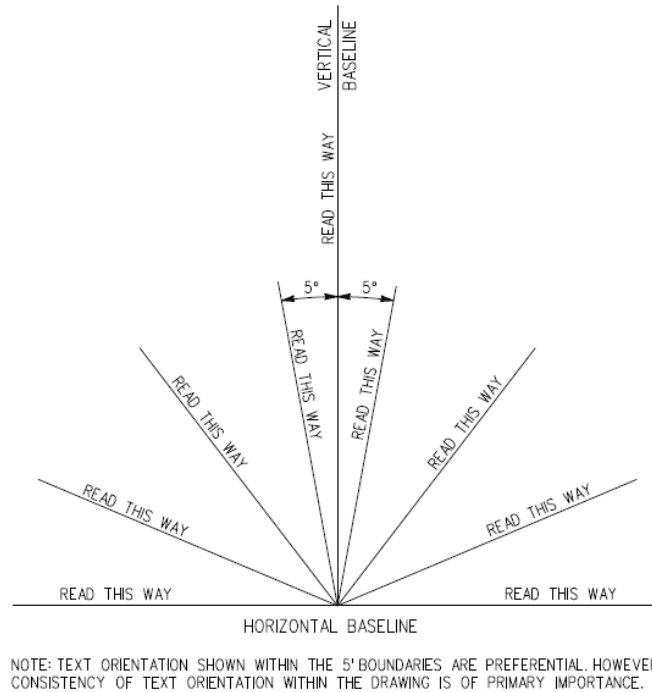

Figure 1.0 Text Orientation

1.3.6 Key Plans

A key plan shall be used, where applicable, to locate the subject of the drawing in relation to the facility or site layout and relationship to other sheets. This plan should be placed in the lower right-hand corner of the sheet, to be visible when the sheet is folded, see [Figure 1.4](#).

1.3.7 North Arrows

All north arrows shall be 2 inches in length (plot scale) as shown on [Figure 1.1](#), and should generally point upward on the sheet or to the right for plans with the EXCEPTION as noted below. When possible, north arrows should not point to the left at an angle greater than 30 degrees.

EXCEPTION: On alignment, railroad trackway, highway and street modifications, and parking lots plans, properly dimensioned and described by stationing limits, north arrow should be oriented and point to true (magnetic) north.

North arrows shall be used to orient all drawings that contain plan views. The location for the north arrow shall be in the upper right hand corner of the drawing. Where drawings contain plan views of differing orientations, the north arrow shall be located in the upper right-hand corner of each view. Refer to User [Appendix 10](#). Use cell, AC=SCRRA NARR from the SCRRA General Cell library.

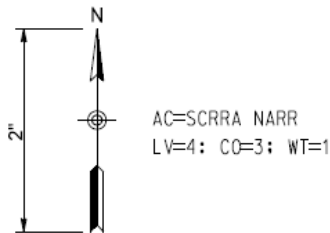

Figure 1.1 North Arrow

1.3.8 **Graphic Scales**

Graphic scales are only required as an aid to assist in scaling and, therefore, are only required on certain types of drawings. These types included: undimensioned project drawings, vicinity maps, drawings produced at irregular scales, civil drawings, utilities drawings, and right-of-way drawings. For different graphic scales, use SCRRA General Cell library, see sample scale in [Figure 1.2](#) below.

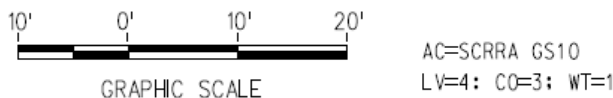

Figure 1.2 Graphic Scale

The basic scale used in each drawing shall be noted in the Border Scale Box. A graphic scale shall be shown as appropriate. The preferred location is above the right side title block clear of the reserved area and below the key plan (if there is one). On a drawing which employs various scales, the scale shall be noted directly below each plan, elevation, section or detail where used, and the entry in the Border Scale Box shall read "AS NOTED". If an elevation, section, etc is not drawn to scale, "NTS" (Not To Scale) shall be placed under its title. When an entire drawing is not drawn to a particular scale, "NTS" shall be shown in the Border Scale Box. For drawings with no scale, the entry shall be "NO SCALE". If the vertical scale is different from the horizontal scale on the same drawing, both scales shall be noted on the Border Scale Box as shown on [Figure 1.3](#).

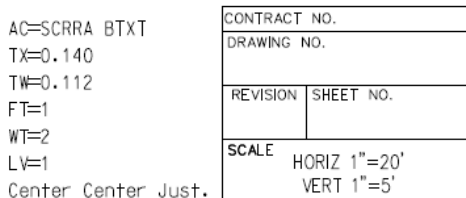

Figure 1.3 Border Scale Box



1.3.9 Drawing Layout

- A. Space shall be reserved above the title block on the right-hand side of a drawing for legends, key plan, graphic scale, (if required) and bills of material. Provide a reserved drawing area 3" long x 1 ½" high in the lower right hand body of the drawing directly above the title block for SCRRA administrative use, see [Figure 1.4](#).

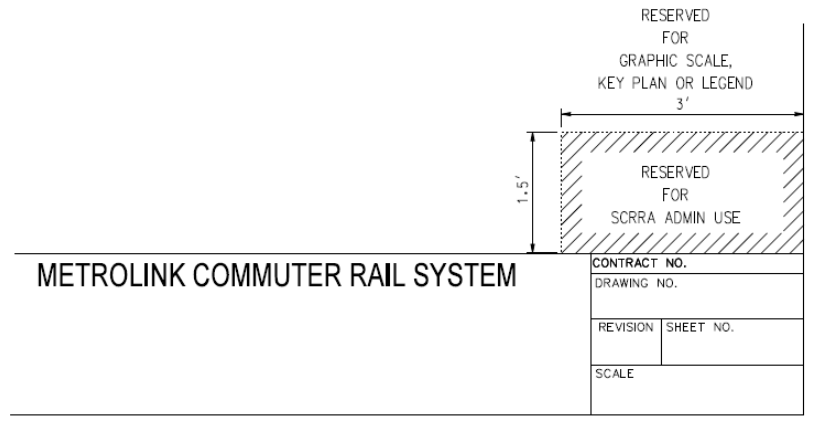

Figure 1.4 SCRRA Administrative Box

- B. The sheet composition shall be simple. Crowding and overlapping of views and details shall be avoided. Details shall be organized so that related details read logically. Group sequencing shall start at the top left of the drawing flowing downward and proceeding left to right. Simple orthographic projection should be used to explain sections. Cutting of complex sections shall be avoided. In general, about one inch of “white space” should separate details, more for sections and elevations.
- C. Where partial views are shown, match lines with reference to matching drawing numbers shall clearly define the limits of work on each sheet.
- D. Dimensions or station match lines shall maintain the continuity of dimensioning of partial plans. If the match line is not on station or grid line, provide dimensioning to the nearest station or grid line.
- E. “N.I.C.” and “Existing” Conditions
 1. Existing – Items or conditions in place at the start of a contract and left in place through completion
 2. N.I.C. – (Not In Contract) New elements or modifications to existing elements that are shown in the drawings but are not part of the contract work.

Every “N.I.C.” and “Existing” item shown on a drawing must be identified. Screening may be used to show existing civil background topography and survey data. Utility drawings may use custom line styles for existing elements. Use



continuous appropriate custom line styles or dash lines to show “N.I.C” and “Existing” conditions.

1.3.10 Notes Layout

Where possible, notes applicable to a whole drawing shall be shown in the upper right hand corner of the drawing, see Figure 1.5. Where this is practical, notes shall be placed at the bottom of the detail drawing.

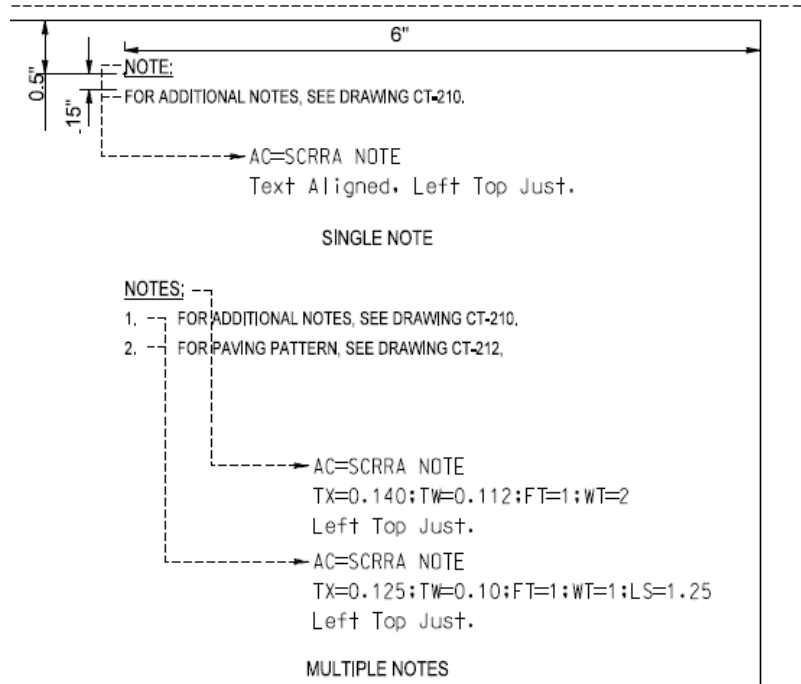

Figure 1.5 Notes Layout

1.3.11 Match Lines

Whenever drawing detail extends across multiple sheets or multiple viewports on the same sheet, match lines shall be provided where the detail begins and ends on each sheet. Match lines shall be in accordance with Figure 1.6. The match line shall be made up of a long dash and two short dashes, repeated as necessary. The long dash shall be 1.5” long with 0.10” space and the short dashes are to be 0.25” long with 0.10” space. One line or two lines of text are acceptable. Match line should be established to be constant across related disciplines, (i.e. architectural, mechanical, electrical, structure or civil. R.O.W. and utilities). Refer to SCRRA General Cell library.

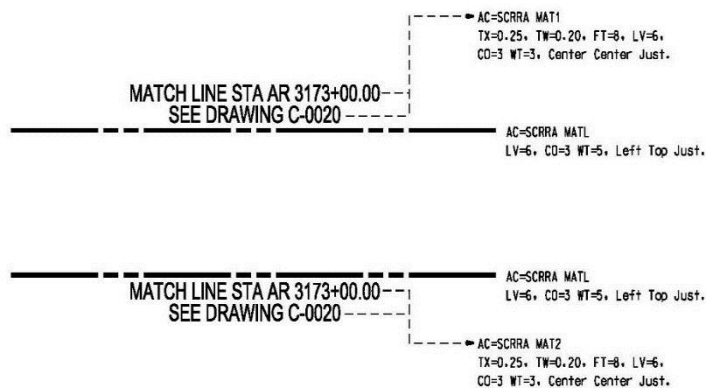

Figure 1.6 Match Lines

If the continuation of the feature is on the same drawing, the label shall read ABOVE/BELOW/RIGHT/LEFT” (for match lines using stationing, the second line shall read “SEE BELOW/ABOVE/RIGHT/LEFT”). Both label lines shall be shown parallel to the match line, outside the limits of drawing coverage with the drawing number being that of the abutting drawing where the feature continues, Match line label text and weight sizes shall be in accordance with [Section 1.6.2](#) and [Table 1.0](#).

1.3.12 Prohibited Techniques

The following drafting techniques are prohibited:

- A. Adhesive or Decals
- B. Adhesive overlays including “zipatone”
- C. Colored paper stock
- D. Colored pencils or markers
- E. Rub-on lettering symbols transfers
- F. Shading
- G. Splicings
- H. Tapes

1.3.13 Sequence of Drawings in Contract Documents

- A. The sequence in which drawings shall be included in all contract document sets prepared for SCRRA shall be as follows;

Common Drawings:

- Cover/Title Sheet
- Index of Drawings
- General Plan/Key Map (Required for more than 10 drawings)



- SCRRA Standard Abbreviations
- SCRRA Standard Symbols
- SCRRA General Notes

Discipline Drawings:

- Construction site plans
 - Existing topography
 - Right-of-way
 - Control surveys
 - Civil
 - Utility
 - Trackwork
 - Geotechnical
 - Structural
 - Architectural
 - Landscaping
 - Mechanical
 - Electrical
 - Traction Power
 - Train Control
 - Communications
 - Automatic Fare Collection (Computer System Engineering)
 - System Integration
 - Reference Drawings (RD drawings)
- B. Within each discipline, the drawings shall be organized as follows;
- General drawings (including abbreviation and symbol sheets if not part of standard drawings) that are discipline specific drawings such as plan, profile and cross sections.
 - Schedules
 - Detail drawings

See [Table 1.1](#) Project Drawing Sheets Order and Scales



1.4 DRAWING FORMAT

1.4.1 Cover Sheet

CADD produced cover showing system map provided by SCRRA as template.

1.4.2 Title Sheet

Every set of contract drawings shall include a Title Sheet in a standardized format that includes the following information:

- A. Submittal Level
- B. Contract Drawings
- C. Contract Number
- D. Contract Title
- E. Date
- F. Volume No.
- G. SCRRA Title and Logo
- H. SCRRA Project Name
- I. Sign-off Blocks, including titles for SCRRA, Consultant and Sub-consultants (if applicable)
- J. Vicinity map showing contract limits and area

1.4.3 Index of Drawings

A standard format for the Index of Drawings can be found on SCRRA General Cell library. See User [Appendix 11](#).

- A. Every set of contract drawings shall include an Index of Drawings. The index may be included as part of a general reference sheet showing notes and a key plan, but it may not be included on the title sheet. The index must always be the first drawing after title sheet. The index shall include the following information as a minimum for each drawing included in the package.
 - 1. Sheet number
 - 2. Drawing number
 - 3. Revision number
 - 4. Title – the drawings shall be categorized by design discipline name.
- B. On large project packages, each sheet, the body of the index shall be portioned into four equally spaced vertical sections. Each section shall consist of four columns headed from left to right as using the cell SCRRA IOD column heading as shown on [Figure 1.7](#).



AC=SCRRA IOD			
TX=0.14, TW=0.112, FT=1, WT=2, LV=45			
SHT	DWG.	REV.	
NO.	NO.	NO.	TITLE

Figure 1.7 Index of Drawings (IOD) Column Heading

- C. The index must reflect the drawing titles accurately and precisely, since it is by reference to the index that the drawings are made part of the contract document. Abbreviations not contained in the drawing titles shall not be used in the index. All

drawings listed in the index that are not included in the in-progress submittals must be marked with a note “Not Included In This Submittal”.

- D. The drawings shall be categorized by design discipline, with all drawings being indexed. Provide a 1” space between last drawing of design discipline and heading of new discipline.
- E. The heading INDEX OF DRAWINGS shall be of text measuring 0.250” high. The text of the column titles shall be 0.140” high and that of discipline headings 0.180” high. The body of the index shall be 0.125” high text. See [Table 1.0](#) on the text fonts and weight.
- F. An adequate blank space shall be provided on each index sheet to permit listing of new drawings that might be generated during the construction phase as design changes occur and are made part of the contract by change order. Blank space requirements shall be between 5 percent and 10 percent of the total index space utilized by the initial issue of project drawings.
- G. Sheet numbers are required on at Final Submittal only and are not required for previous submittals.
- H. Indexes will be updated only when a drawing title is changed; a drawing is added or deleted. When a drawing is deleted from the package, the index may continue to list the drawing number followed by the term “NOT USED” in the drawing title and a change identifier. The entire line will be bubbled.
- I. Drawing Numbers

Drawings will be numbered sequentially under standard alphabetical discipline codes. Numerical sequence will be 3 digits and a “.01” extension. The decimal position will be used for drawings added and inserted after Conformed submittal.

Example: A-023.01 (inserted between A-023 and A-024 after Conformed Submittal)

1.4.4 Layout Index/Key Map

All contract drawing sets with more than ten (10) plan and profile sheets are required to provide a cross reference layout index (key map). The cross reference layout index shall



preferably be one sheet showing the alignment through the project area with a graphic indication of the location of all plan drawings, profile drawings, and/or plan and profile drawings. Each sheet location indicated on the index shall be given a Plan Sheet number, and this number shall be placed in the upper right corner of each corresponding sheet. Thus, in addition to the drawing number, each plan (Existing Conditions Plan, Roadway and Track Alignment, Drainage, etc.) related to a particular section of the line shall have the same number defining its location from the layout index.

1.4.5 Abbreviation Sheet

A Standard Abbreviation Sheet provided by SCRRA Director of Engineering and Construction Department shall be included for each discipline. Additional Abbreviation Sheets, if needed, shall be prepared in equally spaced columns defined by vertical lines, 0.70mm wide. Lettering shall be 0.125-inch high. Abbreviations shall be listed alphabetically with a blank space between different letters.

1.4.6 Symbols Sheet

A Symbols Sheet provided by SCRRA Director of Engineering and Construction Department shall be included for each discipline. The symbols depicted shall be used in preparation of Project drawings. Additional symbol sheets shall be prepared in equally spaced columns defined by vertical lines, 0.70mm wide. Lettering shall be 0.125-inch high with double-spaced lines.

1.4.7 General Notes Sheet

A General Notes Sheet may be included. The text shall be in equally spaced columns, starting in the upper left-hand corner. The main text lettering shall be 0.125-inch with headings of 0.140-inch. Single-line spacing shall be used within a given note and a blank space left between each specific note.

1.4.8 Existing Topography Plans

- A. These drawings shall be prepared from the topographic map data supplied by the SCRRA and/or from survey data. Data shown on topographic maps shall be verified by ground survey where necessary to ensure that elevation and dimensional requirements, as well as constructability of the design can be met. The purpose of the existing topography plan is to serve as the background for the project drawing. Refer to [Table 1.1](#) Project Drawing Sheet Order and Scales.
- B. Specific information to be shown includes:
 - 1. Contours and spot elevations
 - 2. Existing buildings, street, sidewalks, retaining walls, fences, trees, etc.
 - 3. Existing property lines and parcel numbers prior to SCRRA acquisition
 - 4. Names of active commercial businesses and public buildings
 - 5. Buildings to be demolished or severed, if any.



1.4.9 Right-of-way

Right-of-way is the composite total requirements of all factors of real property needed to construct, maintain and operate the transit system.

Organization:

The scale for plans normally as a minimum 1"=40'. Each plan shall contain the following;

- A. Delineated street centerline information
- B. Subdivision information
- C. Parcel identification numbers of impacted properties
- D. County Assessor's parcel numbers for impacted properties
- E. Right-of-way needs lines
- F. Impacted parcel property lines
- G. Tabular listing of parcel grantors, areas, estate, to be acquired and acquisition recording information. Also, upper and/or lower limit elevations if applicable.
- H. Benchmark information if vertical limits are shown on the map sheet.
- I. Reference to adjoining sheets shall be shown as required.
- J. Survey Control Monument

1.4.10 Civil Drawings

Organization:

A. Existing Conditions / Demolition Plans

If required, a demolition plan shall be provided showing the existing site conditions as well as identifying each feature within the limits of work which will require either removal, demolition, protection or relocation.

B. Construction Staging Plans

If required, a construction staging plan shall be prepared showing the availability of various portions of the construction site.

C. Worksite Traffic Control Plans

If required, worksite traffic control plans shall be provided by consultants/sub-consultants.

D. Survey Monument Control

This drawing shall include a plan and details of the Primary Control Survey Monuments within the project area which will be required for field layout control. Survey monumentation shall be based on state plane coordinates. The datum used for horizontal and vertical control shall be stated (e.g., NAD83, NAVD88).

E. Alignment Plan and Data

1. Alignment Data: Refer to [Table 1.1](#) Project Drawing Sheet Order and Scales



- a. Data - A schematic plan of the alignment at no scale, shall show the points along the alignment and all coordinates in tabular form.
 - b. Alignment data shall be arranged in tabular form showing horizontal control points. Tables shall contain the stationing and coordinates of each point, as well as all required curve data.
 - c. Curve data, in tabular form, shall be shown on each alignment plan sheet.
 - d. All curvature and tangent to spiral points on the track centerline shall be shown as open circles 0.125" (plot scale) in diameter, and shall be identified by a radial line to the curve labeling the line with the station and pertinent abbreviation.
 - e. The curve number shall be placed in a rectangle alongside the circular curve.
2. Stationing:
- Each 100-foot station shall be identified by a mark 1/4" long (plot scale). Each 500-foot and 1,000-foot station shall be designated by the full station number. For stationing text height refer to [Table 1.0](#).
3. Passenger Stations:
- a. The outline of Metrolink passenger stations shall be shown by one-inch-long dashed lines, separated by a 0.125" space.
 - b. Track lines shall be shown continuous through the station. The station shall be titled "XXXXXX Station" in or near the station outline, for text height see [Table 1.0](#).
4. Streets:
- Streets and highways adjacent to the tracks shall be identified by pavement lines. Lettering for street names in plan views shall be in accordance with [Table 1.0](#).
5. Match lines:
- a. Each sheet shall bear a match line near each end, drawn perpendicular or radial to the track centerline alignment, preferably at a full 100-foot station.
 - b. Match lines shall be established by Civil and be consistent with the utility drawings. Additional match lines are added by other disciplines as necessary (i.e., station plans, station appendages, and systems drawings).
 - c. Match line label text and weight shall be in accordance with [Table 1.0](#). Refer to [Section 1.3.11](#), [Section 1.6.8](#) and [Figure 1.6](#).

F. Typical Sections



Typical sections of the alignment, railroad trackway, highway and street modifications, and parking lots, properly dimensioned and described by stationing limits, shall be drawn on scale in accordance with [Table 1.1](#). Note any difference in horizontal and vertical scales.

G. Plan and Profile

1. Plan:

a. General:

Line Designation, Curvature, and Stationing shall be as described previously except that points of curvature and equation stations shall be identified only by point symbols and proper abbreviations. Stationing shall be omitted at such points. The scale shall be in accordance with [Table 1.1](#) and may also be used for Grading, Paving, and Drainage Plans. Wherever necessary to meet State Standards (i.e. Caltrans Standards), profile elevations shall be provided in Metric and English units.

b. Stations:

The outline of each Metrolink station shall be as previously described. Track lines shall be shown continuously through the station. The station shall be titled as previously described. Parking areas shall be outlined in a single, solid line.

c. Roadways/Streets:

If frontage roads, access roads, relocated streets, etc., are to be constructed, those roads and streets shall be shown by solid lines defining the edges of the proposed alignment. Termination of existing road or street shall be designated by a single, solid, wavy line. If a bridge is shown, either over the rail line or another railroad or road, the bridge shall be outlined by a solid line. The centerline of roads and structures shall be shown as defined.

All structures under/below others shall be outlined by dashed lines.

Show names of major streets and highways. Text size shall be in accordance with [Table 1.0](#).

d. Railroads:

If existing railroads are to be relocated, the new alignment of tracks shall be shown by a line made up of a long dash and short dash repeated. The long dash shall be 1.0" long, and the short dash shall be 0.05" long with 0.05" space.

Show names of names of railroads. Text size shall be in accordance with [Table 1.0](#).

e. Utilities:



Utilities need not be shown on this plan if a separate utility plan is included in the contract. However, major utilities shall be included here.

f. Right of Way/Political Subdivisions:

City and county lines shall be shown by a line made up of a long dash and two short dashes, repeated. The long dash shall be 0.85" long, and the short dash shall be 0.10" long with .05" space with the pattern repeating along each 1.20" of line. Show names of City and County in appropriate locations.

g. Match Lines:

Each sheet shall bear a match line as described in [Section 1.3.11](#) and [Section 1.6.8](#).

2. Profile:

a. Profile Grid:

For profile scale shall be in accordance with [Table 1.1](#). Elevations shall be entered on the left and right side of each profile grid. The horizontal lines with line weight 3 (WT=3) shall be used at values which are multiples of ten feet (or five feet if vertical scale is 1"=5'). Stationing labels shall be entered at the bottom of the profile grid at every 100 feet. The stationing text height and elevations shall be in accordance with [Table 1.0](#). Wherever necessary to meet State Standards (i.e. Caltrans Standards) profile elevations shall be provided in Metric and English units.

b. Track Profile:

(1) The track profile shall be shown by a single solid line, the top edge of which defines the top-of-rail or the top of the lowest rail (in super elevated length of track). Significant points defining changes in grade shall be shown by an open circle 0.125" in diameter. These points shall be identified by a vertical line placed either above or below the profile, (below on a sag curve and above on a summit curve) drawn to the circle showing the station, and the description above the line and the elevation below the line, reading from the right-hand side of sheet, with text size in accordance with [Table 1.0](#).

(2) Points of horizontal curve shall be labeled on the "R" track profile, without the circle, with text size in accordance with [Table 1.0](#).

c. Track Profile Notes:

The profile shall be labeled "TOP OF RAIL" or "T/R" at least once on each sheet. The rate of grade of vertical tangents shall be labeled above each tangent, for example: "+2.5%", using "+" for ascending slopes in the direction of increasing stationing and "-" for descending slopes in the direction of increasing stationing. The length of vertical



curve shall be shown below the profile and as near the PVI as practical. All letters and numbers text size shall be in accordance with [Table 1.0](#).

d. Ground Line:

The profile of the existing ground along the centerline of Metrolink track shall be shown by a dashed line. If the Metrolink line crosses a body of water, the extreme high and low water surface elevations and the profile of the bottom, if it is known, shall be shown. This profile shall be labeled “EXISTING GROUND” or “OG” at least once per sheet, in accordance with [Table 1.0](#) for text size.

The profile of the proposed grade along the centerline of the track shall be shown by a solid line. This profile shall be labeled “FINISHED GRADE” or “FG” at least once per sheet, in lettering as described above for the existing ground line.

e. Structure Type:

If the Metrolink line is at-grade, in cut, or on fill, no special delineation of structure type shall be made, except that retaining walls shall be shown with lines identifying tops of walls and tops of footings.

If the Metrolink line is on an aerial structure or bridge, the piers, abutments, and the bottom of the spanning structure shall be shown by a solid line. Where the Metrolink line is in subway or tunnel, the top and bottom of the structure, inside and outside, and the portals shall be shown by solid lines.

f. Stations:

Each Metrolink stations shall be drawn to scale. The sides and ends of the station shall be outlined with solid lines. Interior lines for stations shall be solid lines. The track line shall be shown continuously through the station. The station shall be titled as previously described.

g. Overpasses and Underpasses:

If streets, highways, and railroads cross over or under the Metrolink line, the centerline intersection shall be shown in the profile using a light centerline symbol, and the section of the structure shall be indicated in solid lines for proposed structures and shaded dotted line for existing structures, The name of the street, highway, and railroad shall be noted vertically along the centerline symbol in letters 0.14" high (plot scale). If the structure exists, it shall be labeled “existing.” All existing or proposed track clearances shall be indicated.

h. Utilities:

All major underground utilities lines, such as sewers, storm drains, water mains, oil pipelines and fiber optic cables, shall be shown in



profile crossing the Metrolink line. A note stating that locations are not accurate maybe included.

i. Match Lines:

Vertical match lines shall be designated as in [Section 1.3.11](#) and [Section 1.6.8](#). In addition, the elevation of the profile grade shall be shown at each match line.

j. Profile Grade Elevations:

Profile grade elevations at even 100-foot intervals, at each end point of vertical curves, grade breaks and, at the beginning and end of the project, shall be shown along grid lines at the bottom of the profile grid.

H. Project Cross Sections

1. Cross sections at uniform intervals shall be drawn to indicate construction details such as outline of track features, i.e. ballast, sub ballast, ties, rail etc and limits of earthwork. Refer to [Table 1.1](#) for recommended scale.
2. Trackway and roadway cross sections shall be perpendicular to the centerline of the "R" track or center of roadway and generally shall be taken at 50-foot intervals and at sharp breaks in the terrain. In terrain where the difference in elevation between the profile grade line and the ground surface varies uniformly, cross sections may be taken at 100-foot intervals.
3. Utilization of data from ground survey is preferred to interpolate the existing contours for showing existing ground line.
4. Cross sections shall be done at locations of major utilities or where there may be conflicts with existing structures.

I. Grading, Paving, and Drainage Plans

1. Purpose:

The primary purpose of grading, paving, and drainage plans is to define construction along the trackway and at parking lots, access roads, city and county streets, highways, etc., adjacent to the Metrolink line. These drawings are for construction of new or restoration of existing facilities.

For scales, refer to [Table 1.1](#).

2. Information shown:

- a. Plan shall show outline of structure, street center lines, walls, easement and temporary and permanent needs lines, sidewalks, curbs, alleys, catch basins, retaining walls, manholes, fences, guard rails, and other surface features to be constructed or affected by Metrolink construction. Typical sections, existing and new elevations, cross sections or cross section information, type of pavement, curbs, and other details for areas to be paved, repaved, or restored, shall be



shown or referenced to other plans. Elevations of street surfaces to be matched shall be indicated and existing elevations shall be shown in parenthesis (). The pay limits of areas to be constructed or restored shall be clearly defined and shall include a reasonable area outside the limits of excavation, approximately 15 feet, or more, and areas impacted by utilities relocation(s).

- b. Drainage information shall include layout of new and relocated utility facilities with “join existing” points clearly marked. Show size and material of pipes and types of channels and gutters. Cross reference shall be made to profiles and details on other drawings.
- c. Profile shall include cross section of the existing and proposed utilities and, at intervals of 50 feet and breaks in grade, show original and proposed elevations at points on profile and at edge of restoration. Include existing elevations at flow line.
- d. Paving plans shall include centerline elevations and elevations at each curb line showing flow line or top of curb line unless profiles are shown on Pavement Profiles, Details, and Section Drawings. Curbs shall meet the affected city requirements.
- e. If restoration includes adjoining sidewalk, with or without curb, show areaways, window walls, doorways, RCC gratings, and other pertinent surface features and existing and proposed elevations in sufficient detail to clearly indicate slope and warping of sidewalk to assure that areas are properly drained.
- f. Show control elevations at the tangent points of the street corners or fillets, and at points to be matched.
- g. Breaks in grade in excess of 0.50% require a vertical curve, and both breaks in grade and vertical curves shall be noted.
- h. Locate and note trees to be saved.
- i. Unless notified to the contrary by the Consultant, disturbed areas not to be otherwise altered shall be restored to match the adjoining properties, alleys, and streets.
- j. Unless otherwise shown, restoration work on local streets and highways shall conform to the Terms of Agreement between Metrolink and the agencies and municipalities involved. SCRRA standards and criteria shall be followed for construction within SCRRA right-of-way.
- k. Contours defining finished grades and finished pavement elevations shall be drawn as solid lines. Every ten-foot major contour (e.g., 940, 950, and 960) shall be drawn as a heavy solid line. The minor contour interval shall not exceed two feet, and each major contour shall be labeled at least once on each sheet.
- l. Easement and permanent and temporary needs lines shall be sufficient for proposed Metrolink facilities, utilities, roadway and railroad rearrangements, access, and construction. All points shall be



shown in tabular form on this drawing or on a separate drawing. Tables shall contain the number and coordinates of each point. When easement and needs lines become too extensive and obscure other information to be shown on this plan, it may be advisable to show all property information on a separate RIGHT-OF-WAY plan.

3. Drainage Profiles and Details

- a. Major storm drain profiles shall be drawn to scale in accordance with [Table 1.1](#).
- b. Show types of manholes, catch basins, and inlets. Indicate centerline location of manholes, catch basins, and inlets by station and offsets from baselines established for the project or other dimensions. Indicate material, diameter, bedding, slope, and length of pipes.
- c. Invert elevations for pipes at drainage structures and elevation of grates and manhole covers shall be shown.
- d. Cross-reference shall be made to plan drawings and details not shown on standard drawing.

J. Street and Roadway Pavement Profiles, Details, and Sections

Profiles and miscellaneous sections and details for roadways, streets, curbs, driveways, and parking lots required to define vertical elements shown on pavement and grading plans shall be indicated on the drawings, as follows:

1. Streets and Roadways

a. Profile Grid:

Scale shall be in accordance with [Table 1.1](#). Elevations shall be entered on the left and right side of each profile grid at 1" intervals, where the heavy horizontal lines occur. The heavy horizontal lines shall be assigned values which are multiples of one, five or ten feet, depending on the vertical scale. The lettering for the elevations shall be 0.14" high. Stationing labels shall be entered at the bottom of the profile grid at every 100 feet, increasing from left to right. The lettering for the grid stations shall be 0.18" high. The profile(s) titles shall be labeled "PROFILE @ TOP OF XXXX CURB" OR "PROFILE @ CENTERLINE XXX STREET." The lettering for these labels shall be in accordance of [Table 1.0](#).

b. Street Profile:

- i. The street or roadway profile shall consist of a minimum of three parts, where applicable, consisting of the two curbs and the centerline profiles. Preferably all three profiles shall be shown on the same sheet. The top of curb(s) profile(s) shall be shown by a single solid line, the top edge of which defines the top of the curb. The centerline profile shall also be shown by a single solid line, of the same line weight, representing the street centerline finished grade. Significant points defining changes in vertical grade shall



be shown by an open circle 0.125" in diameter. These points shall be identified by a vertical line placed either above or below the profile line, drawn to the circle. The vertical line shall show the station and label on the left of the vertical line, and the elevation on the right side, reading from the right-hand side of the sheet, with 0.14" high lettering. Horizontal points of curvature, (BCs, ECs, BCRs, and ECRs), shall be shown with an open 0.125" diameter circle, and labeled as above.

- ii. The points of intersection of the profile tangents shall be indicated by an open 1/8 inch triangle. The BVC and the EVC shall be labeled with the station and the elevation. Intermediate stations shall be shown and labeled for vertical curves longer than one hundred feet. Between the limits of the vertical lines defining the BVC and the EVC, the vertical curve length and station and elevation of the PVI shall be shown conveniently above or below the profile. Vertical grade breaks with an algebraic difference of less than 0.5% do not need to be connected with vertical curves. Lettering for the vertical curve information shall be 0.14" high. (Occasionally these criteria may be superseded by the governing City, County, or agency ultimately owning the improvements as defined in the Terms of Agreement between SCRRA and the agencies and municipalities involved.)
 - iii. For clarity, the lengths of curb returns at street corners shall be shown, straightened out, to scale, either on the main profile(s), or on insets on the sheet, or on a separate sheet(s). The BCR/ECR of the intersecting street shall be labeled with the correct street name, station and elevation, as well as the station and elevation of the street being profiled. The BCR and ECR shall be designated with circles, as described on previous page. The curb return(s) shall be broken into four (4) equal parts between the BCR and ECR, and designated with vertical lines intersecting the profile line. The vertical lines intersecting the profile line need not have the 0.125" circle on the profile. The spaces between the vertical lines on the curb return shall be labeled $\Delta/4$, and elevations assigned to each of these quarter points.
- c. Street, Roadway Profile Notes:
- i. The profile shall be labeled "TOP OF NEW CURB" and "FINISHED CENTERLINE ELEVATION," as appropriate. (The centerline symbol may be used in lieu of spelling out the words). Where joining existing improvements, the existing elevations shall be shown in parenthesis (), and the station and the word(s) JOIN shall be shown on the profile. The rate of grade of the vertical tangents shall be labeled above each tangent line, using "+" for ascending slopes in the direction of increasing stationing, and using "-" for descending slopes in the direction of increasing stationing. The rates of grade shall be shown as a percentage, representing the change in vertical elevations per 100 feet. The rate shall be shown as numbers followed by a percent (%) sign.



The use of “s” is reserved for open channel flows, and shall not be used on street profiles. All lettering shall be in accordance of [Table 1.0](#).

- ii. The profile of the existing street centerline shall be shown by a dashed line. This profile shall be labeled “CENTERLINE EXISTING GRADE” at least once per sheet. (The symbol for centerline may be used in lieu of the words centerline.) The profile(s) of the existing ground line or existing top of curb(s) under the proposed curb line(s), shall be labeled “EXISTING GRADE” or “TOP OF EXISTING CURB,” as appropriate.

d. Sections and Details:

- i. Typical and special sections should be drawn to scale length-wise at no less than 1"=5'. The height may be exaggerated for clarity.
- ii. Details should be provided for clarity. Details not drawn to scale are to be discouraged, except in extreme cases where clarity cannot be adequately shown.

2. Parking Lots and Other Surface Improvements

Generally parking lots and other improved surface areas do not require profiles. Vertical elements to be constructed are better shown and labeled on the plan view(s).

a. Section and Details:

- i. At least one typical section shall be shown, cutting through the site. Extra sections shall be cut through the site to show complex grading, walls, slopes, paving or other unique features to adequately provide the contractor information on existing conditions or show how to construct the features.
- ii. Typical and special sections shall be drawn to scale in accordance with [Table 1.1](#). The height may be exaggerated for clarity.
- iii. Details should be provided for clarity. Details that are not shown to scale are discouraged, except in extreme cases where clarity cannot be adequately shown.

K. Standard Drawings

Standard drawings of local jurisdictions shall be used as much as possible. Standard plans shall be included in the project drawings set. Copying of details shall be avoided. Standard drawings shall be part of all disciplines standard drawings placed at the end of each contract.

1.4.11 Utilities

Based on the magnitude of the impact to the existing utilities, a separate set of utility plans may be required as part of the contract drawings. It is the Designer’s responsibility to coordinate the scope with the SCRRA’s Project Manager.



A. Standard Utilities Abbreviations, Symbols and General Notes

The Standard Utilities Abbreviations, Symbols Drawing(s) will include abbreviations and symbols that pertain to utilities. These drawings shall be prepared by the Designer. Standard drawings shall be part of all disciplines standard drawings placed at the end of each contract.

B. Composite Plan or Existing Utility Plan

1. Purpose:

Composite utility plans shall be prepared to show the interrelationship of existing utilities and streets in the project area. Utilities shall be designated as existing or abandoned, and the type, size, and material of each shall be indicated using the symbols shown on the Utility Abbreviations, Symbols, and Standard Drawings.

Where the size warrants, facilities shall be drawn to scale. Unless otherwise indicated, the centerline of the utility will be used for scale reference.

2. Utilities to be shown:

The following utilities, including their ancillary facilities, shall be shown on the drawings:

- a. Underground and overhead electrical facilities including all services
- b. Water mains as well as domestic and fire services
- c. Sanitary sewer lines including house connections and all appurtenances
- d. Storm drain facilities
- e. Underground and overhead copper and fiber optic facilities
- f. Gas mains including all services and appurtenances
- g. Underground and overhead cable television facilities
- h. Fuel or oil lines
- i. Underground and overhead street light and traffic signal facilities
- j. Railroad communication and signal cables
- k. Miscellaneous e.g. abandoned utility lines, cables, pipes, manholes, vaults, railroad tracks, and any substructure related to utilities that is being impacted by the Metrolink facilities.

3. Utility designations, utility line codes and text:

- a. Utility line designations shall be placed horizontally and perpendicular to right or left borders. When descriptive



information is required, place directly above that specific utility facility.

- b. Flag all sewer manholes, labeling top (RIM) and invert in the manner described in the utility abbreviation and notes shown on the Standard Drawings.
- c. For line designations and necessary descriptive information, use the following:
 - (1) 1"=40': 0.125" high text or H = 0.125
 - (2) 1"=20': 0.14" high text or H = 0.140
- d. On scale 1"= 20', lines outlining existing utility facilities shall be dashed lines 1-1/2" long with a 1/10" space between lines. Major underground utilities, 24" and larger on scale 1"=20', and 36" and larger on scale 1"=40', shall be shown with a dashed double line. Major overhead lines shall have a line width greater than that shown for the underground utility lines.

4. Scale:

Refer to [Table 1.1](#).

C. Composite Utility Rearrangement Plan

1. Purpose:

Composite Utility Rearrangement Plans shall show all existing facilities, temporary and permanent rearrangements. These drawings are to ensure that no conflicts are inadvertently designed into the project and that adequate space is available for construction of each utility.

2. Scale:

Refer to [Table 1.1](#). The scale of the composite rearrangement plans shall match the scale of the existing utility plans.

3. General:

Composite utility rearrangement plans shall be prepared using screened copies of the composite existing utility plans for base sheets.

These plans shall show all utility rearrangements with sufficient designations to identify each utility line and structure. Descriptive notes and information shown on individual utility rearrangement plans shall not be repeated on the composite plans. Existing utility lines and notes shall be lighter than proposed utility lines and notes.

D. Utility Rearrangement Plans, Profiles, and Details

1. Purpose:

Utility rearrangement plans, profiles, and details shall be prepared based upon coordinated agreements with utility owners and as authorized by



SCRRA, including utilities relocation work to be performed by other than the facility contractor. Facilities of more than one utility owner may be shown on a set of utility rearrangement plans provided details of each utility network are clear and the plans are not congested. These drawings are for construction of new and restoration of existing utilities or to show utility work to be done within the project area either by the facility contractor or utility owners.

2. Scales:

Refer to [Table 1.1](#).

3. Information Shown:

a. In areas affected by construction, prepare utilities rearrangement plans, profiles, and details if applicable:

- (1) Electrical facilities and all services including new service to Metrolink Station.
- (2) Water mains, as well as domestic and fire services including water lines which will serve the Metrolink Station.
- (3) Sanitary sewer lines, house connections and all appurtenances including sump pump connections (if any) from the Metrolink Station.
- (4) Storm drain facilities including sump pump connections (if any) from the Metrolink Station.
- (5) Telephone copper and fiber optic facilities including all services.
- (6) Gas mains including all services and appurtenances.
- (7) Cable television lines and facilities.
- (8) Street light and traffic signal facilities.
- (9) Railroad communication and signal cables.

b. Utility rearrangement plans shall show only that work pertaining to the utility or utilities indicated by the plan title. The type, size, material, and owner of each utility shall be indicated by the use of the appropriate abbreviations.

c. Proposed utility lines shall be a solid line. Major underground utilities and overhead lines shall be drawn using the legends and labels as shown on the Utility Abbreviations, Symbols Drawings.

d. Existing utility lines and notes shall be lighter than proposed utility lines and notes.



1.4.12 Street Lighting and Traffic Signal Drawings

Preparation of the temporary and permanent traffic signal and street lighting plans will be coordinated by the consultants with the governing municipality.

1.4.13 Trackwork

Organization

- A. Trackwork Installation Contracts
 - a. Trackwork abbreviations, symbols, general notes
 - b. Mainline schematic and special trackwork locations
 - c. Construction staging area plan(s)
 - d. Rail welding site(s)
 - e. Track Drawings
 - (1) Track alignment schematic
 - (2) Track alignment data
 - (3) Track plans
 - (4) Track profiles
 - (5) Track cross-sections
 - (6) Road and walkway plans
 - (7) Road alignment data
 - (8) Road profiles
 - (9) Road cross-sections
 - (10) Yard details
 - f. Mainline track charts
 - g. Special trackwork plans and details
 - h. Track typical sections and details
 - i. Index of reference drawings to be included in package from Facilities contracts
- B. Special Trackwork Procurement Contracts
 - a. Abbreviations, symbols, general notes
 - b. Turnout plans
 - c. Switch plans



- d. Frog plan
 - e. Crossover plans
 - f. Crossing diamond plans
 - g. Guard rails
 - h. Miscellaneous special trackwork details
- C. Scales

Refer to [Table 1.1](#).

1.4.14 Geotechnical

Organization

- A. Location plan boring logs
- B. Log of boring
- C. Scale: Refer to [Table 1.1](#).
- D. Information Shown:
 - a. The streets, major buildings and outline of transit structure. Boreholes shall be located and numbered according to the soils report prepared by the Geotechnical Consultant. Explanation of Geological units, symbols and notes.
 - b. Logs of Borings will be shown on separate drawings prepared by the Geotechnical Consultant.

1.4.15 Structural Drawings

Project drawing sets will not necessarily include all of the sheets listed in this section, depending upon the types of structures involved and the site conditions. The general order of arrangement shall be adhered to; omit those drawings not applicable

There will be three basic groups of structures; a project might contain any combination of the following groups and sub-items:

- A. Structures that follow the alignment such as subway cut-and-cover line, tunnel, aerial line, subway stations, aerial stations, and at grade stations;
- B. Appurtenant facilities such as entrances, ventilation shafts, pump shafts, emergency exits, sub-stations, and buildings.
- C. Special grade separation structures such as overpasses and underpasses, retaining walls, drainage structures, and utilities structures.

Organization

- A. General Structural Notes



The Standard Structural Abbreviations, Symbols, and General Notes sheet will include abbreviations, symbols, and notes that pertain to the structural drawings. Standard drawings shall be part of all disciplines standard drawings placed at the end of each contract.

B. Construction Structures Criteria

These sheets will be for use by the Contractors in arranging and designing their temporary decking and temporary support systems. Included will be criteria for decking loads; sheeting and bracing loads; analysis and design; lateral pressures caused by soil, water, and surcharge; tiebacks; excavation and bracing procedures; allowable bearing values; observation installations; and cofferdam arrangements.

C. Aerial and/or Subway Structure Control Schedules

These drawings will show, in tabular form, the basic data for construction.

D. General Structural Arrangement

In plan, the outline of structure shall be superimposed on a simple outline of the street system. For scale, refer to [Table 1.1](#).

In profile, the ground surface at the centerline of structure, the outline of structure, and the track profile grade line shall be shown. If the profile grade lines of adjacent tracks are not the same, profiles of each track shall be shown. The elevation of top of low-running rail shall be shown to the nearest one-hundredth of a foot at significant locations. For scale, refer to [Table 1.1](#).

E. Underpinning and Protection

The scale of underpinning drawings shall be selected to suit the particular building being underpinned. Drawings shall be complete in detail and shall clearly describe and indicate the method of underpinning to be used or the protection wall systems that might be required. Loads on existing columns and walls to be underpinned shall be shown.

F. Structural Plans

These drawings shall show the concrete outline and reinforcing details necessary to supplement those which are shown on elevations, sections, and details. Show clearance dimensions, tie-ins, joints, openings, rooms, etc. Drawings shall be arranged in sequence starting with lowest level, e.g., foundation plan or track level plan, and progressing to roof level. For scales, refer to [Table 1.1](#).

In some instances, structures might be represented by combination of plans, elevations, sections, and details on the same drawing.

G. Structural Elevations, Sections, and Details

Views shall be referenced to the structural plans and shall show concrete and reinforcing adequate for detailing of reinforcing steel. For scales, refer to [Table 1.1](#).

H. Structural Steel Framing Plans



Show plans of columns, girders, beams, framing relationships, and designation of structural steel members. For scales, refer to [Table 1.1](#).

I. Structural Steel Schedule and Details

Include schedules for columns, girders, and beams in tabular form, and details for joints and splices, end bearings and connections, stiffeners, anchor bolts, studs, base plates, bolting and welding, etc. For scales, refer to [Table 1.1](#).

J. Appurtenant Structures

This grouping pertains to entrances, ventilation shafts and fan rooms, emergency exits, pump stations, etc., which are contiguous to the rail line or station structure. Plans, elevations, sections, and details for each may be shown in the order outlined above or on the same sheet as space needs dictate. For scales, refer to [Table 1.1](#).

K. Special Structures

This grouping includes overpasses, underpasses, nonstandard retaining walls, drainage structures, substations, utilities structures, and other miscellaneous structures not otherwise categorized. Scale shall be selected to suit structure, see [Table 1.1](#).

L. Miscellaneous Iron and Steel

Include details for doors and frames, railings and handrail gratings and support members, ladders and stairs, anchor bolts and inserts, etc. Standards will be provided by SCRRA where feasible. For scales, refer to [Table 1.1](#).

M. Standard Structural Drawings

The standard structural drawings will include standard aerial structures, standard subway structures, and standard structural elements of aerial stations. Detailed information will be presented in tabular form with required plans, sections, etc.

1.4.16 Architectural Drawings

Project drawings will not necessarily include all of the sheets listed. The general order shall be adhered to for uniformity.

- A. Abbreviations, Material Indications and Symbols shall comply with the AIA standards.
- B. Formats for Door Schedules and Finish Schedules shall comply with industry standards.

Organization

A. Site Plans

Site plans include items such as building locations, station entry, emergency exit hatches, train ventilation shafts and grates, property lines, street names and centerline, walkways, curbs, ramps, parking area, drains, light poles and site



furniture such as bike tracks and bike lockers. Station outline shall be shown in dashed line and centerline of track as reference.

B. General Arrangement Plans

All levels of the station shall be shown. Information includes items such as stationing, top of rail elevation, module identification grid, north arrow and sheet identification.

C. Floor Plans and Roof Plans

Floor plans shall include room names, room numbers and door numbers. Show openings at slab with solid line, openings at ceiling and walls with dash line. Plans shall include information drawn by other disciplines but attach as reference and shall not be copied to architectural plans and made active elements. Such elements include floor drainage and equipment pads. Also include information such as column grid, north arrow, key map, wall material indications, sections and enlarged plans detail designations.

Roof plans shall show direction(s) of slope(s), if any, roof penetrations, material callouts, and other features and necessary information including relevant dimensions and detail references.

The scale of floor and roof plans shall be 1/8"=1'.

D. Longitudinal and Transverse Sections

One longitudinal section and sufficient number of transverse sections shall be provided to depict building compositions in sections through track/platform and mezzanine levels. Sections shall also provide floor to ceiling heights, section through the roof and shafts to the surface, and stairs and escalators for vertical circulation.

Longitudinal and transverse sections with all relevant vertical dimensions, callouts, and other information shall be of such locations as needed to depict the overall building design.

Scales to be used shall be 1/8"=1'.

E. Exterior Elevations

Exterior elevations shall show all exterior views of the facility, complete with relevant vertical dimensions, material callouts, detail references, and other necessary information.

The scale of exterior elevations shall be 1/8"=1' or 1/4"=1', as appropriate, to show the information.

F. Reflected Ceiling Plans

Reflected ceiling plans are drawings which include light fixtures, directional arrows for emergency exiting lights, fire rated duct enclosures, PA speakers, openings for ducts, ceiling grid layout at public spaces, signage, illuminated sign



band and edge lights, equipment hoisting I-beam drawn by others and shown as referenced, section and detail designations.

G. Interior Elevations

Interior elevations shall show relevant dimensions, callouts, and other necessary information which cannot be accurately or clearly defined by plans.

The scale of interior elevations shall be 1/4"=1'.

H. Detail Plans, Sections and Elevations

Detail plans, sections and elevations shall be shown at scales appropriate to the information to be presented and shall include all relevant dimensions, callouts, and other information needed.

Scales to be used shall be 1/4"=1' or 1/2"=1', or as appropriate

I. Details

Details shall be included in sufficient number to clearly depict the building design and shall include all relevant dimensions, material callouts, and other detailed information.

Scales to be used shall be 3/4"=1', 1"=1', 1-1/2"=1' or 3"=1', Half-Size, or Full-Size as appropriate.

J. Paving Plans

Paving plans shall include all floor patterning, finish detail references, and material call outs. Paving plans shall include plaza level, mezzanine and platform levels.

K. Acoustical Finish and Fire Rating Plans

Acoustical finish drawings shall include plans longitudinal and transverse rating sections of areas that require acoustical finish treatment. Fire rating plans shall include plans of all areas indicating the fire ratings of walls and ceilings.

L. Schedules

Door schedules typically show the door number together with its size, fire resistance rating, door type, hardware sets, location of doors by room and floor levels, special equipment requirements and head, jamb and sill detail references.

Finish schedules typically show space/room identification, room numbers, material finishes, and finish for all floors, walls and ceilings, including height, by room. In addition, these schedules shall include standard material abbreviations and wall orientation information such as north, south, east and west.

1.4.17 Illuminated Signs, Signage and Graphics

Signage and graphics schedules, plans, layouts, sections, details, elevations and pictograms shall be shown at a scale appropriate to the information to be presented and shall include all relevant dimensions, sizes, colors and any other information needed.



All plans shall locate the applicable signs with its designation and symbol. Each plan shall include sign schedule describing the location, message code, message and reference drawings for sign details. Plans shall include room names, north arrow, key map and station column grid.

Organization

1. Site Plan
2. Floor Plan (at public areas only)
3. Symbols, Abbreviation
4. Sign Types

1.4.18 Landscaping

Landscape drawings shall show all landscaping with details and the irrigation systems at station's site/plaza areas, parking lots (if any), slope areas and parkway areas.

Organization

1. Planting and Irrigation Legend
2. Landscape Planting Plan
3. Landscape Irrigation Plan
4. Landscape Planting Details
5. Landscape Irrigation Details

1.4.19 Signing and Pavement Marking

Signing and pavement marking plans shall be drawn for all parking lots and roadways per SCRRA criteria and latest standard drawings, per MUTCD, CALTRANS or local requirements for city of county facilities.

A. Signing and Pavement Marking Details

Non-standard or special signs and pavement marking shall be drawn with sufficient detail and dimensions to enable the contractor to prepare templates for fabrication and/or installation.

1.4.20 Mechanical Drawings

Organization

A. Mechanical M-Series - HVAC

- a. General Arrangement Plan shall define the contract limits and references to the partial plans.
- b. HVAC Equipment Schedules describes the performance of equipment. It also includes general notes.



- c. Floor Plans, Roof Plans, Enlarged Plans, Cross Sections shall be drawn to scale in accordance with [Table 1.1](#).
- d. Air Flow Diagrams - It is a schematic representation of air systems which shows the CFM, spaces, etc. of the system served. It must also show how the systems are connected to common exhaust and intake shafts.
- e. Control Diagrams - These diagrams must clearly show how each system is controlled and also show where remote signals are relayed. To assist in the understanding of the control diagram, an operating sequence must be written.
- f. Details - Typical details generally are shown on directive or standard drawings, however it may be necessary to develop additional, project specific details.

B. Mechanical FP-Series - Plumbing and Fire Protection

These follow the same general order as the M-Series Drawings and in addition it shall include:

- a. Site Plan – shall be drawn in accordance with [Table 1.1](#).
- b. Arrangement of toilets shall be enlarged and drawn in accordance of [Table 1.1](#).
- c. All plans shall include graphic scale as standard.

1.4.21 Electrical Drawings

The detail drawings and schedules shall define all requirements in specific areas such as stations, station platforms and communication shelters.

Organization

Project drawings will not necessarily require all the sheets listed below, depending on structure involved. The general order shall be adhered to for uniformity, omitting those drawings that are not applicable. Standard and directive drawings, as required, will be supplied by the SCRRA. Electrical drawings shall consist of:

- 1. Plan drawings which illustrate all electrical systems including:
 - a. Lighting and illuminated signs plans
 - b. Power distribution and Fare Collection (Ticket Vending Machine) plans
 - c. Public address, supervisory and control, telephone systems, and fire and intrusion plans
 - d. Wayside and line section plans, including sections and details
 - e. Grounding and cathodic protection plans
 - f. Signal conduit systems (for pedestrian crossings).



2. Electrical Diagrammatical Drawings shall include:
 - a. One-line diagram to describe electrical power system and describe its short circuit characteristics.
 - b. Riser diagrams for grounding
 - c. Riser diagrams for communication shelters, supervisory and control, public address, closed circuit TV, telephone system, fire and intrusion, and fare collection systems.
 - d. Elementary wiring diagrams where functional definition of the system is required.
 3. Detail Drawings shall include:
 - a. Major room layouts, (auxiliary electric rooms, ventilation, power utility room, train control and communications room, traction power room etc)
 - b. Wall elevation in auxiliary electric rooms, where needed, to position equipment or components within a limited area.
 - c. Detail drawings showing methods of installation, equipment configuration, fixture mounting, etc.
 - d. Layouts of facilities terminal cabinets, if any.
 - e. Emergency Management Panel
 4. Schedules: Conduits, cables, panels, lighting, and power distribution systems.
 5. Elementary wiring and connection drawings shall include site specific circuit diagrams developed from the directive drawings. Terminal numbering scheme shown on directive drawings shall be followed to develop site specific drawings.
 6. Facility system wide interface drawings shall include detail layouts of facility systemwide boxes, terminal strip and protector block schedules, etc. Details required for the interface of two different contracts shall be defined. Terminal numbering scheme shown on directive drawing shall be followed to develop site specific drawings.
- B. Electrical standard plan symbols, diagram symbols, and notes to be included in the project drawing set, after verification of all applicable notes and symbols.
- C. Site Plan or Entry Plan
1. Scale: Refer to [Table 1.1](#).
 2. A plan view of the structure divided into numbered structural units shall be shown. Indicate the general layout of structures, and show project limits, major facilities, and sufficient stationing.
 3. Sectional views and details necessary to clearly define structures presented on Key Plans shall be adequately referenced.



D. Detail Drawings

1. Scale: Refer to [Table 1.1](#).
2. Electrical drawings of the station areas shall be used to show the location of the following: embedded conduits; control panels; ticket vending equipments; PA/CMS systems; normal and emergency lighting fixtures; signs; switches; receptacles, transformers; control and disconnect equipment; grounding facilities; feeds for heating, ventilating, and pumping equipment; escalators; and elevators.
3. Detail drawings shall identify each room and space, and show the calculated foot-candle level for each room and space and the location of conduit for auxiliary electrical, and communication facilities. Include a one-line diagram from the incoming power service through all sub-panel boards.
4. Section views and details, scale 1/4"= 1'-0" shall clearly illustrate conduit arrangement and define details necessary for installation.

E. Conduit Schedule

A schedule which separates the auxiliary electrical and emergency electrical communication power conduit requirements shall be included with drawings.

F. Panelboard Schedule

A panelboard schedule shall be prepared for all main and subpanel boards. Schedules shall be as illustrated on directive drawings.

G. Electrical Service Plan and Profiles, and Details

Prepare plan and profile and detail drawings of the SES duct line and manholes to be constructed within the SCRRA right-of-way. These drawings shall be drawn per SCRRA criteria and latest standard drawings and directives and per Power Company requirements.

1.4.22 Systems

The following are typical drawings to be prepared by the system group:

A. Train Control

The train control system provides three major functions: Automatic Train Protection (ATP), Automatic Train Operation (ATO) and Automatic Train Supervision (ATS), to enforce train safety, control train movements and direct train operations on the main line and in the yard.

Organization

Project drawings will not necessarily include all the sheets listed. The general order shall be adhered to for uniformity.

1. Symbols sheet
2. Abbreviations sheet



3. General notes
4. Layout index sheets
5. Line schematic sheets
6. Track plans
7. Conduit plans
8. Route and aspect charts
9. Interlocking layouts
10. Room layouts
11. Typical installation layouts
12. Highway grade crossing layouts
13. Typical crossing assemblies
14. Power distribution drawings
15. Frequency drawings
16. Schematic circuit drawings
17. Typical arrangement layouts

B. Communications Installation

Communications System shall provide the necessary subsystems to support the total operational requirements of the Metrolink System.

Organization:

1. Symbols sheet
2. Abbreviations sheet
3. TC&C room layouts
4. ROC drawings
5. System block diagram
6. TC&C rooms - seismic bracing

C. Signage and Graphics

Signage and graphics drawings are usually camera ready finished artwork and do not comply with drafting standards unless drawings are created to accompany the artwork.

D. Cable Transmission System

The Cable Transmission System incorporates the transmission system and the cable distribution within passenger station area, buildings, etc. Provides all voice and data transmission circuits between the Central Control Facility and all fixed locations along the Metrolink System.

Organization



Project drawings will not necessarily include all the sheets listed. The general order shall be adhered to for uniformity.

1. Symbols sheet
2. Abbreviations sheet
3. Systems block diagrams
4. Typical system interconnect drawings
5. Duct bank & conduit assignment sheets
6. Duct bank layouts
7. Emergency trip switch drawings
8. Power distribution drawings
9. Emergency trip drawings
10. Existing cable termination sheets
11. Existing cable layout drawings
12. Cable assignments
13. Cable plans
14. Cable terminations
15. Typical communication and signaling layout sheets
16. Interface drawings
17. Frame drawings
18. Tabulation drawings
19. Equipment drawings
20. Station equipment plans
21. Reference drawings

E. Traction Power

Power supplied to Metrolink System for operation of trains. The distribution system, either contact rail or substations and the running rails supply overhead contact systems, which provides the trains with power.

Organization

Project drawings will not necessarily include all the sheets listed. The general order shall be adhered to for uniformity. There are two types of Traction Power contacts listed separately below.

Traction Power Supply System

1. Symbols sheet
2. Abbreviations sheet
3. Single line diagrams
4. AC and DC metering and relaying diagrams
5. Equipment layout drawings
6. Special nameplate schedules and details



7. PLC control schematic diagrams

Traction Power Installation

1. Symbols sheet
2. Abbreviations sheet
3. Equipment interconnection block diagrams
4. Equipment arrangement plans
5. Raceway layouts
6. Schedules:
 - a. Conduit schedule sheets
 - b. Cable schedule sheets
 - c. Wire interconnection schedule sheets
 - d. Panel schedule sheets
7. Details:
 - a. Electrical detail drawings
 - b. Manhole installation detail drawings
 - c. Equipment installation detail drawings
 - d. Equipment installation detail drawings
 - e. 35kv Train way feeder installation detail drawings
 - f. Motorized disconnect switch detail drawings
 - g. Authority furnished equipment and installation detail drawings
 - h. Cable termination detail drawings
 - i. Cable adapter detail drawings
 - j. Cable connection and expansion joint detail drawings
8. Index of reference drawings

F. Overhead Contact System

The OCS includes the catenary system, the physical support system and the associated feeder system.

Organization

Project drawings will not necessary include all the sheets listed. The general order shall be adhered to for uniformity.

1. Symbols and Abbreviations sheet
2. Assembly drawing index
3. Site plan and typical configuration
4. Master schematic layout
5. Sectionalization plans
6. Tension section arrangements
7. Typical arrangements



8. Typical structure plans
9. General loading diagrams
10. Cantilever assembly drawings
11. Pole assembly drawings
12. Layout schedules
13. Feeder plans
14. Circuit schedule sheets



1.5 DRAWING BORDER AND TITLE BLOCK

The standard drawing border and title block format SCRRA-BDR and with entry data field cell, SCRRA-BTXT developed in accordance with this Section are described below and shown as well in [Section 2.6.3](#). See User [Appendix 10](#).

Except for the Cover Sheet, all drawings shall include the drawing border and the entry data field cell text.

The drawing border and the entry data field cell shall not be “EXPLODED”, substituted, or modified.

1.5.1 Abbreviations

Abbreviations in the title block are not allowed except in the following cases:

Words such as street, road, avenue, drive, highway and compass directions

BRS	Blast Relief Shaft
CBD	Central Business District
CMS	Changeable Message Sign
EB	East Bound
FAI	Fresh Air Intake
FT	Foot or Feet
HRT	Heavy Rail Transit
L	Left
LA	Los Angeles
LRT	Light Rail Transit
MCC	Motor Control Center
MISC	Miscellaneous
N.A	Not Applicable
NO.	Number
NB	North Bound
N.T.S.	Not To Scale
OCS	Overhead Contact System
R	Right
ROC	Rail Operation Center
SAV	Stand Alone Validator
SB	South Bound
SCADA	Supervisory Control and Data Company Acquisition
SHT	Sheet
STA	Station
TC	Track Center
THRU	Through
TVM	Ticket Vending Machine
UPE	Under Platform Exhaust
UPS	Uninterrupted Power Supply
VCTC	Ventura County Transportation Commission



VMS	Variable Message Sign
WB	West Bound

1.5.2 Drawing Title Box

Drawing title box text style and size refer to [Table 1.0](#). The contents of the Drawing Title block and placement of the text shall be in accordance with [Figure 1.8](#). See User [Appendix 10](#).

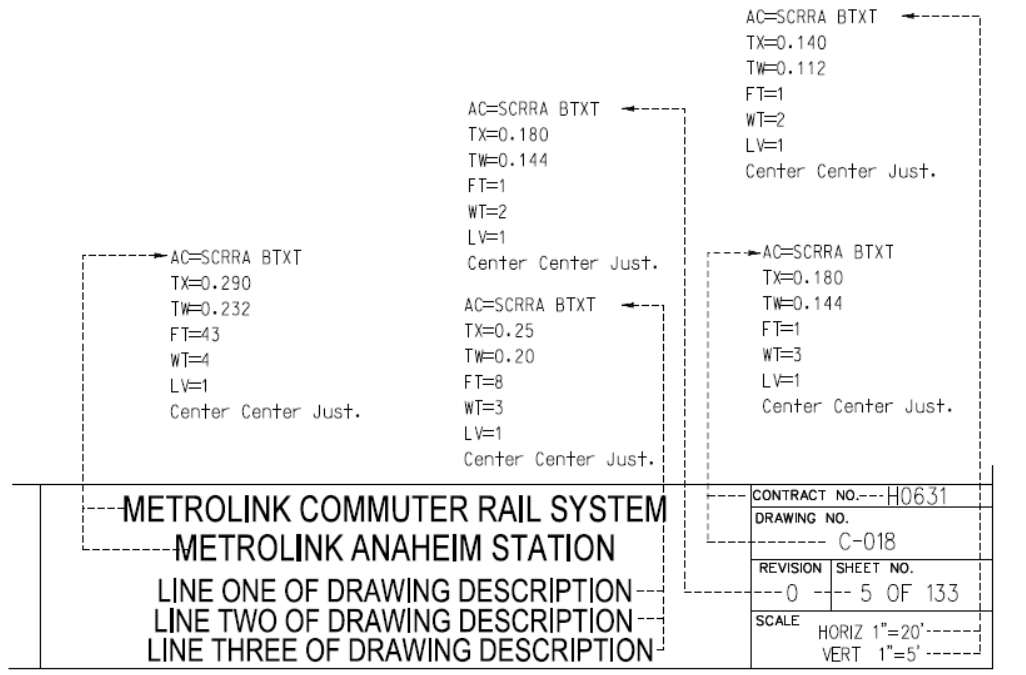

Figure 1.8 Drawing Title Block Configuration

The title shall include as follows;

- A. Drawing Title - Lines One and Two
 - 1. Line one shall indicate the basic “METROLINK COMMUTER RAIL SYSTEM”. It shall be centered within the drawing title block as the upper most line.
 - 2. Line two shall indicate the name of the contract (i.e., “METROLINK ANAHEIM STATION”).

B. Drawing Title - Lines Three Through Five

Each drawing title should be unique in identification and should avoid the use of abbreviations. Abbreviations should only be used if there is not adequate space and if it is listed in Section 1.8.2K. When several drawings depict similar data, and no other qualifications are available for distinguishing the sheet, then the distinction shall be made by labeling each such sheet consecutively as sheet 1 of 4, sheet 2 of 4, etc., within the titles. Plan and profile sheets shall be distinguished by indicating beginning and end point civil stationing. Drawing titles



appear on the contract drawings must read exactly the same as those listed on the index of drawings.

The text in the Title Block shall not contain the following characters;

- Double Quotes (“
- Apostrophe (’)
- Question mark (?)
- Asterisk (*)
- Colon (:)
- ‘At’ Symbol (@)
- Greater Than (>)
- Less Than (<)
- Pipe (|)

1.5.3 Contract Number Box

Contract Number must be confirmed on a project by project basis. The contract number shall consist of 4 to 9 characters; i.e. first character is a letter followed by 3 or 4 digit number assigned to the contract. Should there be an additional task prior to the contract number issued on a project, an extension identifier 4 characters; i.e. (-) dash followed by 3 digit number will be added on the contract number.

All contract numbers shall be written as follows: C631, C6410 or H0631, H0631-015 and shall be entered into the “CONTRACT NO.” box.

Such number should be assigned by the SCRRA Assistant Director, Contracts and Procurement, refer to [Figure 1.8](#).

1.5.4 Drawing Number Box

All project, standard, and directive drawing numbers, with the exception of communications and signaling drawing numbers, ([Figure 1.8](#)) shall be in accordance with the following:

- A. Each drawing number shall be composed of two segments. The first segment shall identify the subject of the drawing by the discipline codes.
- B. A hyphen shall separate the first and second segment.
- C. The second segment shall be numeric of four digits starting 0001 and progressing for the subject or discipline.
- D. Numbering system shall be developed for each contract so that numbering of plans, sections, and elevation are consistent in each discipline when possible.



- E. Drawing numbers followed by letters, such as A68A and A68B are not recommended.
- F. Drawings added to a contract following baseline issue will carry a decimal extension (e.g., .01, .02, etc) and is inserted between two existing integer sheet numbers.

1.5.5 Sheet Number Box

The sheet number defines the drawings in consecutive numerical order in the set of project drawings. The sheet numbers being shown on the drawing and index must agree. The sheet numbers may be added on the PDF using Adobe Acrobat or BlueBeam Software during design and construction review submittal. However, at the time the Record Drawings are provided to SCRRA the sheet number must be incorporated into CAD attributed to the Title Block cell SCRRA BTXT. Hand lettered sheet numbers will not be acceptable on the Record Drawings.

A sheet number shall be assigned to each sheet in a set of drawings when issued. Numbering shall begin with the title sheet and use format shown on [Figure 1.8](#). A set of drawings shall be organized in order with accordance [Table 1.1](#) Project Drawing Sheets Order and Scales.

1.5.6 Revision Level Box

The revision level as shown in [Figure 1.8](#) shall be assigned to each drawing in accordance with [Chapter 3](#) Revision Guidelines and Criteria.

1.5.7 Scale Box

The scale used in each drawing shall be noted in the Border Scale Box. If the vertical scale is different from the horizontal scale on the same drawing, both scales shall be noted, as shown in [Figure 1.8](#).

If a single scale is used on the drawing, then the scale shall be entered numerically in this box such as 1"=20', or 1/4"=1'-0". When an entire drawing is made to the same scale, that scale shall be indicated in the scale box of the title block. Drawings with multiple details having the same scale do not require individual scale call out.

If more than one scale is used on the drawing or if a part of the drawing is not drawn to scale, the entry in this box shall be "AS NOTED". Each individual portion of the drawing (section, detail, excavations) shall then specifically note the scale used.

When any work on a drawing such as plan, detail, view or section is not drawn to scale, the entry shall be "NTS", i.e. Not To Scale on the scale box.

For drawings such as the Index of Drawings, Abbreviations & Symbols, Calculation Tables sheets, where a scale is not applicable, "NO SCALE" should be entered in the scale box.

If different scales are used on a drawing, "AS NOTED" shall be entered in the scale box. Each individual portion of the drawing (section, detail, excavations) shall then specifically note the scale used.



1.5.8 Design Engineering Consultant Box

The company logo of the consultant or sub-consultant responsible for the design as shown on sample [Figure 1.9](#), shall be placed in this box. Design Engineering Consultant identification will be incorporated into the established cell SCRRA BTXT on SCRRA General Cell library.

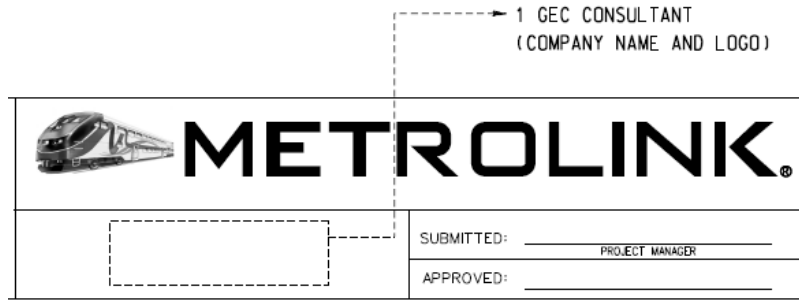

Figure 1.9 Design Engineering Consultant Box

1.5.9 Professional Seal Box

When a professional seal and signature is require on a drawing, the engineer or architect responsible for the design shall affix his/her electronic seal info using the SCRRA Seal format in the SCRRA General Cell library.

The consultant’s or sub-consultant’s design manager signature shall be electronically or digitized signature. Tiff file signature are not acceptable. See [Figure 1.10](#).

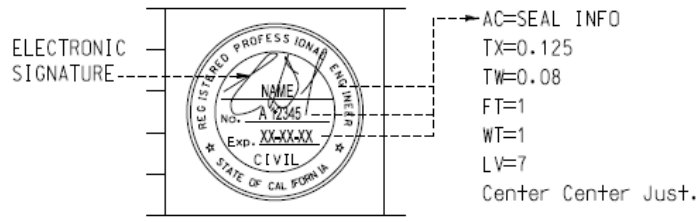

Figure 1.10 Professional Seal Box

1.5.10 Design/Drawn/Checked/Approved Boxes

The required information must be filled in prior to the submittal for design approval. All entries on the drawings shall be made with uppercase letters left top justified as shown on [Figure 1.11](#). Refer to User [Appendix 10](#).

- A. “Designed By” – Name of the person who performed the major portion of the engineering design work
- B. “Drawn By” - Name of the person who performed the major portion of the drafting work



- C. "Checked By" - Name of the person who performed the major portion of the checking
- D. "Approved" - Name of the discipline professional "in responsible charge" who approves the accuracy of the content of the drawing.

DESIGNED BY D. ESIGNER --	AC=SCRRA BTXT TX=0.140, TW=0.112, FT=1 WT=2, LV=1, Left Top Just.
DRAWN BY D. RAFTER --	
CHECKED BY C. HECKER --	
APPROVED BY I. NCHARGE --	
DATE 05-04-2016 --	

Figure 1.11 Design By\Drawn By\Checked By\Approved By\Date Box

1.5.11 Date Box

The date on which the responsible design professional approves, seals and signs a drawing shall be entered in this box as shown on [Figure 1.11](#). Months shall be expressed as in the following table;

01-January	04-April	07-July	10-October
02-February	05-May	08-August	11-November
03-March	06-June	09-September	12-December

The date format shall be shown as in this example: 01-24-2016 (month-day-year)

1.5.12 Revision Block Box

Revisions information shall be entered using SCRRA cells for revisions. More information concerning entries to make in the revision block ([Figure 1.12](#)) fields is given in [Section 3.1.5](#).

AC=SCRRA REV				
0	05-04-16	ISSUED FOR BID	CH	IN
REV.	DATE		BY SUB.	APP.

Figure 1.12 Revision Block Box



1.5.13 Plot Stamp

All hard copy submittal shall have a plot stamp showing the time and date of creation, the path to the source file and the user login name current at the time the plot command was executed see [Figure 1.13](#) for the stamp's configuration and placement on the lower left corner outside of the border. Stamping plots in this way prevents any confusion as to which ones are the most current and allows the source file to be found easily. The plot stamp used is a text string embedded in SCRRA border file. The plot stamp updates automatically each time a file is opened and plotted.

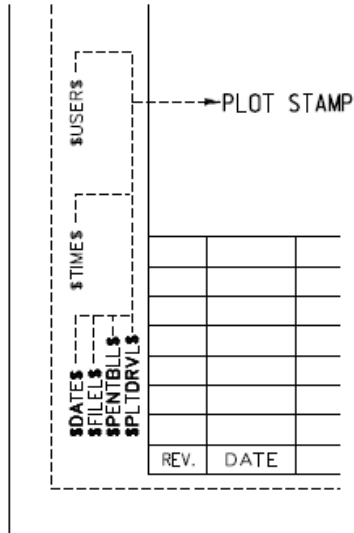

Figure 1.13 Plot Stamp Placement



1.6 SPECIFIC REQUIREMENTS

1.6.1 Linework

Linework on design drawings must be plotted in black. No color other than black is allowed. All lettering and numbering must be kept clear of linework.

Line thickness may vary according to object(s) shown and the need for clarity and differentiation.

1.6.2 Lettering - General

All lettering shall be vertical uppercase and of appropriate weight and clarity that it can be easily read from a “50% reduced size” print. In any contract set uniformity shall be maintained.

All lettering shall be done using CADD systems. The minimum letter size is 1/8". Text width shall be 80 percent of text height (MicroStation notation: tw = .8 x text height) except for title sheets and for special graphics, see below [Table 1.0](#).

Lettering and figures shall be compact without crowding. The space between lines of lettering shall be at half of the height of the letters. Avoid fitted text where possible.

Text shall be oriented to read from bottom or from the right edge of drawing. In no case shall orientation be greater than 105 degrees counterclockwise past alignment with the bottom edge of drawing.

Table 1.0 Text Height, Font and Weight

DESCRIPTION	ENGLISH SIZE	FONT	WEIGHT	SLANT
Main Title Project Description (Line 1 and 2 in Title Block)	TX = 0.29	43	4	0
Sub Titles (Line 3, 4 and 5 in the Title Block), Main Headings on Index of Drawings and Match Line	TX = 0.25	8 (Arial)	3	0
Titles for Quantity Tables and Detail Drawings Begin and End Construction on Title Sheet	TX = 0.24	43	0	0
For Pacific Ocean	TX = 0.24	3	2	25
Country and State boundary	TX = 0.22	43	0	0
City, Streets, County and Highway Names (Title Sheet Strip Map)	TX = 0.20 **	43	0	0
Track Names, Station Names, Alignment Names, Profile title	TX = 0.20	43	2	0
Begin and End Work on Title Sheet. Titles for Informational Tables	TX = 0.20	3	2	0
Contract Number, Drawing Number and Sheet Number in the Title Block, Discipline Headings on the Index of Drawings, Subtitles for Tables and Detail Drawings. Route & Route No, Line Designation *** Headings inside a Quantity Table	TH = 0.18 TW = 0.144 ****	1	3	0
Revision Number in Title Block, Profile Grid Stationing	TX = 0.18	1	2	0
As-built Changes	TX = 0.175	3	2	15
Scale, Design By, Drawn By, Checked By and Date in Title Block General Notes title, Plan Drawing Scale, Alignment Stationing Text, Track Profile Data, Track Curve Data and Notes, Profile Title, River Names (Water Ways)	TX = 0.14 TW=0.112	1 (ENG'G)	2	0
Column Title on Index of Drawings	TX = 0.14 TW=0.112	8	2	0
All Notes, Dimensions, General Notations, Tables, Schedules, and Indexes County Lines and City Limit Lines	TX = 0.125	1 3*	1	0
Dimensioning Parameters	TX=0.125 TW=0.100	1	1	0



SCRRA CADD Manual

Profile Grid Elevations Restricted Space for Placement of Text	TH = 0.125 TW = 0.125	3	0	0
Name, Date, License Number Inside Seal and Date of Signature	TH = 0.125 TW = 0.10	3	1	0
Printed Names in Margin of Border Sheet	TX = 0.125	3	1	0
Seal Info Text (Engineer's Name, License No. and Expiration Date)	TX = 0.10 TW=0.08	1	1	0
Photogrammetric Mapping Text, Survey Topographic Mapping Text such as Existing Elevations	TX = 0.10 TW=0.10	1	0	0



- * Shall be used in those Schedules, Tables and Drawing Indexes where items require text to line up.
 - * On Dimensions TW=0.100 adjustable if necessary (TX = 12 minimum).
 - ** For projects spanning multiple counties, which are identified on the Title Sheet, the text size and font for cities may be reduced to TX= 0.14, Font= 3 and WT= 1, so the counties can be shown more prominently than cities.
 - *** If a Layout Sheet has multiple routes and is a busy and cluttered sheet, making it difficult to see the route labeling, then the Route, Route Number and Line Designation may be placed using
TX= 0.14, Font= 43, WT= 0 for routes with work or
TX= 0.14, Font= 3, WT= 1 for routes without work.

For Title Sheets having a strip map that covers a large area (multiple counties), the route identification may be placed using TX= 0.14, Font= 3, WT= 1 for routes without work.
 - **** Reduce text width (TW = 0.14 minimum), if needed for restricted space when placing a heading inside a quantity table.
 - ***** Do not use Font 23. It is obsolete and does not have the appropriate spacing for characters or the desired appearance for certain letters. Use the Caltrans standard Font 3 (cfont1) and place at a slant angle of 25 degrees.
- Note: Text sizes for additional information on contract plans not listed in the above table see the individual sections and examples in the Plans Preparation Manual.

1.6.3 Abbreviations

Abbreviations of words on project drawings shall be held to a minimum to ensure clarity and lessen the chance that the abbreviated word could be misinterpreted. Abbreviations used in drawings shall be limited to those included either on the general abbreviation sheet(s) or in the discipline abbreviation sheet(s) where they occur. Where an abbreviation sheet applies to more than one discipline, the applicable disciplines shall be indicated.

The general and discipline Abbreviation Sheets, where provide, shall be used in all project drawing sets. Where Abbreviation Sheet(s) supplement the standard sheet(s), the abbreviations contained therein shall conform to ASME (latest edition)

Discipline abbreviation sheet(s) shall not contain abbreviations in conflict with those included in the general or other discipline abbreviation sheet(s) included in a drawing set.



Abbreviations in drawing titles shall conform to the requirements of [Section 1.5.1](#).

1.6.4 **Graphic Symbols**

Symbols shall be shown on the Standard Abbreviations and Symbols sheet for each discipline. Graphic symbols other than those shown on discipline standard drawings may be used in accordance with the following:

- A. Architectural: Graphic Standards (latest edition), AIA
- B. Reinforced Concrete: Manual of Standard Practice for Detailing Reinforced Concrete Structures (latest edition), ACI Manual 315
- C. Structural Steel Detailing: Steel Construction Manual (latest edition) and Structural Shop Drafting Text Book (latest edition), AISC
- D. Welding Symbols: Standard Welding Symbols (latest edition), American Welding Society
- E. Mechanical Symbols: ASHRAE Standard and current accepted practice
- F. Electrical Symbols: IEEE Standards and current accepted practice
- G. Plumbing: Uniform Plumbing Code/National Plumbing Code (latest edition), ASA A40.8

1.6.5 **Notes**

All general notes, construction notes and any other notes covering applicable material specifications, bill of material, design criteria, and special instructions to the fabricator and/or installer. Additional columns may be used for notes with the information always reading from left to right.

Use cell format SCRRA NOTE from SCRRA General Cell library. See [Section 1.3.10](#) and User [Appendix 10](#).

Specific notes shall be located on the drawings near the item to which they apply. A leader line with arrow/line terminator shall connect the note and the item. Care shall be taken to place the arrowhead appropriately to clearly indicate the item to which the note applies.

1.6.6 **Scales**

The scales to which drawings are plotted shall be determined by the specific requirement of the work; however, similar scales shall be used throughout a document set for similar elements of the design. Graphic scale shall be in all drawings. Refer to [Table 1.1](#) for the recommended scale on all drawing sheets to be used throughout a project stationing.

Each 100-foot station shall be identified by a mark 1/4" long and is based upon finished full size plot of 22"x 34". Each 500-foot and 1,000-foot station shall be designated by the full station number.

Stationing requires no more than two decimal places. Coordinates require no more than four decimal places.



Station equations shall be shown as per Engineering Standards. The equation shall be shown on a line drawn perpendicular to the stationed line.

Table 1.1 Project Drawing Sheets Order and Scales

DRAWING ORDER	TITLE	HORIZONTAL SCALE	VERTICAL SCALE
General			
	Cover Sheets	No Scale	
	Title Sheets	No Scale	
	Index of Drawings	No Scale	
	General Plan		
	Layout index	1"=800'	
	Abbreviation Sheet	No Scale	
	Symbols Sheet	No Scale	
	General Notes	No Scale	
Civil			
	General Civil Notes, Abbreviations and Symbols	No scale	
	Existing Topography and Demolition Plans	1"=20' or 1"=40' (Min)	
	Right of Way Plans	1"=40'	
	Alignment Plan Data	1"=40'	
	Alignment Plan and Profile	1"=40' 1"=20'	1"=10' 1"=5'
	Survey Monument Control Data	As Required	
	Plan and Profile	1"=40'	1"=4'
	Site Plan	1"=20' or 1"=40' (Min)	
	Typical Cross Sections	1"=20' 1"=5' (Min)	1"=2' Varies
	Typical Details	1/2"=1'-0"	
	Grading, Drainage and Paving Plans	1"=20' or 1"=40' (Min)	
	Drainage Profiles and Details	1"=40' 1"=20'	1"=10' 1"=5'
	Pavement Profiles and Details	1"=40' 1"=20'	1"=10' 1"=5'
	Project Cross Sections	1"=10'	1"=10'
	Construction Staging Plans	As Required	
	Traffic Maintenance Plans	1"=20' or 1"=40' (Min)	
	Area Station Direction Signage Plans	NTS (Not To Scale)	
	Signage and Pavement Marking Plans	As Required	
	Street Lighting Plans, Profile and Details	1"=20'	1"=5'
	Lighting Details	As Required	
	Traffic Signal Plans	1"=20' or 1"=40' (Min)	
	Civil Standard Drawings		
Utilities			



DRAWING ORDER	TITLE	HORIZONTAL SCALE	VERTICAL SCALE
	General Utilities Notes, Abbreviations and Symbols	No Scale	
	Composite Plan of Existing Utilities	1"=20' or 1"=40' (Min)	
	Composite Plans of Utility Rearrangement	1"=20' or 1"=40' (Min)	
	Utility Profile	1"=20'	1"=5'
	Utility Cross Sections (As Required)	1"=10'	1"=10'
	Utility Plan and Profile	1"=20'	1"=5'
	Utility Details	1/4"=1'-0", 1/2"=1'-0", 3/4"=1'-0"	
	Utility Standard Drawings		
Trackwork			
	General Trackwork Notes, Abbreviations and Symbols	No Scale	
	Mainline Track Charts	1"=100'	1"=10' or No Scale
	Typical Track Sections	1"=5'	
	Yard Plans	1"=20' or 1"=40' (Min)	
	Yard Profiles	1"=20' or 1"=40' (Min)	
	Yard Cross Sections	1"=5' or 1"=10' (Min)	
	Special Trackwork Details	1/4"=1'-0" to Full Scale	
	Special Trackwork Key Plan	No Scale	
	Special Trackwork Complex Alignment Plans and Details	1"=5'	
	Turnout and Track Crossing Alignment Plans and Details	1"=5'	
	Turnout and Track Crossing Plans	1/4"=1'-0"	
	Turnout and Track Crossing Details	1 1/2"=1'-0" to Full Scale	
	Switch & Frog Plans	3/4"=1'-0"	
	Crossover Plans	1/4"=1'-0" (Std) or 1/8"=1'-0" (Min)	
	Miscellaneous Track Appurtenances Plans and Details	1"=5'	
	Miscellaneous Track Trackwork Details	1 1/2"=1'-0" to Full Scale	
	Trackwork Drainage Plans and Details	1"=5'	
	Trackwork Composite Plans and Details	1"=10' (Plans) 1 1/2"=1'-0" (Details)	
	Mobilization and Construction Access Areas	1"=5'	
	Maintenance of Way Access Plans and Details	1"=5' (Plans) 1 1/2"=1'-0" (Details)	
	Construction Staging Plans	1"=5' (Plans) 1 1/2"=1'-0" (Details)	



DRAWING ORDER	TITLE	HORIZONTAL SCALE	VERTICAL SCALE
	Area for Receiving, Welding and Storing Rail	1"=20' (Plans) 1 1/2"=1'-0" (Details)	
	Trackwork Storage Areas	1"=20' (Plans) 1 1/2"=1'-0" (Details)	
	Procurement and Construction Schedule	No Scale	
Geotechnical			
	General Geotechnical Notes, Abbreviations and Symbols	No Scale	
	Boring Location Plans and Profiles	1"=100' or 1"=200' (Min) (Plans) 1"=10' or 1"=20' (Min) (Profiles)	
	Boring Logs	As Required	
Structural			
	Abbreviations and Symbols, General Structural Notes, Loads and Design Criteria	No Scale	
	General Plan and Elevation	1"=10' or 1"=20' (Min)	
	Foundation Plan/Track Level Plan Aerial Structure Foundation Plans	1/8"=1'-0", 1/4"=1'-0", 3/16"=1'-0" 1"=10' or 1"=20' (Min)	
	Structural Steel Framing Plans	1/8"=1'-0", 1/16"=1'-0"	
	Structural Elevations, Sections and Details	1/8"=1'-0", to 1/2"=1'-0" (Elevations) 1/4"=1'-0" to 1"=1'-0" (Sections) 1/4"=1'-0" to 3"=1'-0" (Details)	
	Structural Steel Schedule and Details	1/2"=1'-0", 1 1/2"=1'-0"	
	Appurtenant Structures Plan Elevations and Sections	1/8"=1'-0" to 1/4"=1'-0"	
	Special Structures	1/8"=1'-0" to 1 1/2"=1'-0"	
	Miscellaneous Iron and Steel Details	1/4"=1'-0" to 3"=1'-0"	
	Plans (Standard)	1/8"=1'-0" or 1/4"=1'-0"	
	Plans (Tunnel)	1"=40'	
	Plans (Stations)	1"=20'	
	Longitudinal Sections	1/8"=1'-0"	
	Transverse Sections	1/4"=1'-0"	
	Elevations	1/4"=1'-0"	
	Details and Various Sections	As Required	
	Enlarged Plans	3/16"=1'-0"	
Architectural			
	General Architectural Abbreviations and Symbols		
	Site Plan	1"=40' Desirable 1"=20' (If used on civil	



DRAWING ORDER	TITLE	HORIZONTAL SCALE	VERTICAL SCALE
		drawings)	
	General Arrangement Plans	1"=30'-0" or 1"=40'-0"	
	Floor Plans, Roof Plans Reflected Ceiling Plans	1/8"=1'-0" 1/8"=1'-0" or 1/4"=1'-0" (Reflected Ceiling Plans)	
	Paving Plans	1/4"=1'-0"	
	Enlarged Plans	1/4"=1'-0"	
	Interior and Exterior Elevations	1/4"=1'-0"	
	Miscellaneous Elevations	1/8"=1'-0", 1/4"=1'-0", 1/2"=1'-0" (Min)	
	Longitudinal Sections	1/8"=1'-0"	
	Transverse Sections	1/8"=1'-0" or 1/4"=1'-0"	
	Miscellaneous Sections	1/8"=1'-0", 1/4"=1'-0", 3/16"=1'-0"	
	Details	1/2"=1'-0", 3/4"=1'-0", 1 1/2"=1'-0" 3"=1'-0", Half Full Size or Full Size	
	Door Schedules and Finish Schedules	NTS	
	Signage and Graphic Schedules	As Required	
Landscaping			
	General Planting Notes, Planting and Irrigation Legend	No Scale	
	Planting/Irrigation Key Plan	1"=100'	
	Landscape Planting Plan	1"=40' Desirable 1"=20' (If used on civil drawings)	
	Landscape Irrigation Plan	1"=40' Desirable 1"=20' (If used on civil drawings)	
	Landscape Planting Details	3/4"=1'-0", 1 1/2"=1'-0", 3"=1'-0" or Half Size	
	Landscape Irrigation Details	3/4"=1'-0", 1 1/2"=1'-0", 3"=1'-0" or Half Size	
Mechanical			
	Mechanical Abbreviations	No Scale	
	Mechanical Symbols	No Scale	
	Key Site Plan	1"=40'	
	Plumbing and Drainage Station Plans (Concourse and Platform)	1/8"=1'-0"	
	Plumbing and Drainage Equipment Room Layout (enlarged Plans and Details)	1/4"=1'-0"	
	Plumbing and Drainage Riser Diagrams	NTS	
	Miscellaneous Piping Systems	NTS	
	Plumbing and Drainage	No Scale	



DRAWING ORDER	TITLE	HORIZONTAL SCALE	VERTICAL SCALE
	Schedules		
	Schedules (Lighting, Power Panel, Conduit, etc)		
	Fire Protection Station Plans (Concourse and Platform)	1/8"=1'-0"	
	Fire Protection Equipment Room Layout (Enlarged Plans and Details)	1/4"=1'-0"	
	HVAC Station Plans (Concourse and Platform)	1/8"=1'-0"	
	HVAC Equipment Room Layout (Enlarged Plans and Details)	1/4"=1'-0", 1/2"=1'-0", 1"=1'-0"	
	Cross Sections	1/4"=1'-0", 1/2"=1'-0", 1"=1'-0"	
	HVAC Control Systems and Instrumentation	No Scale	
	HVAC Flow Diagrams	No Scale	
	HVAC Schedules	No Scale	
	Standard Plumbing Drawings		
	Standard Fire Protection Drawings		
Electrical			
	Electrical Abbreviations	No Scale	
	Electrical Layout Symbols	No Scale	
	Electrical Diagram Symbols	No Scale	
	Composite Plan, Site Plan	1"=40' 1"=20' (If used on civil drawings)	
	Diagrams	No Scale	
	Exterior Lighting Plan	1"=40'	
	Interior Lighting and Auxiliary Plans Lighting and Illuminated Sign Plans	1/8"=1'-0" Min	
	Power Control & Grounding Plan	1/8"=1'-0"	
	Communication Plan	1/8"=1'-0"	
	Equipment Room Layouts Enlarged Plans	1/4"=1'-0"	
	Power and Grounding Riser Diagrams Control Diagrams	NTS	
	Details	As Required 3/8"=1'-0" 1/8"=1'-0" for detail plan drawings	
	Cross Sections, Section Views and Details	1/4"=1'-0"	
	Conduit Schedule/ Panelboard Schedule	No Scale	



DRAWING ORDER	TITLE	HORIZONTAL SCALE	VERTICAL SCALE
<i>Traction Power</i>			
	Abbreviations, Symbols and General Notes	No Scale	
	Schematic Track Plan	No Scale	
	Device List	No Scale	
	Single-line and Three-line Diagrams	No Scale	
	Control Schematics	No Scale	
	Traction Power Facility and Raceway Layouts	1"=40' 1"=20' (If used on electrical drawings)	
	Wiring Diagrams		
	Conduit and Cable Schedules		
	Contact Rail Layout For Turnouts and Special Trackwork	1"=40' or 1"=20' (If used on electrical drawings) 1"=10' or 1"=5'	
	Contact Rail Installation Drawings - Coverboard Plan Detailed drawings - Coverboard installation Plan drawings	1/4"=1'-0" to 1/2"= 1'-0" 3/8"=1'-0" to 3/4"=1'-0"	
	Sections or Cross Sections	1"=1'-0" or 1/2"=1'-0"	
<i>Train Control</i>			
	Abbreviations, Symbols and General Notes	No Scale	
	Subsystem Block Diagrams	No Scale	
	Track Diagrams/Charts	No Scale	
	Equipment Arrangement Plans Facility Layout Plans	1"=40' 1"=20' (If used on electrical drawings)	
	Installation Details/Bill of Materials	As Required	
	Conduit and Cable Schedules	No Scale	
	Standard Drawings		
<i>Communication</i>			
	Abbreviations, Symbols and General Notes	No Scale	
	Subsystem Block Diagrams	No Scale	
	Functional Block Diagrams	No Scale	
	Riser Diagrams	No Scale	
	Equipment Arrangement Plans Facility Layout Plans	1"=40' 1"=20' (If used on electrical drawings)	
	Installation Details/Bill of Materials	As Required	
	Conduit and Cable Schedules	No Scale	
	Standard Drawings		
<i>Automatic Fare</i>			



DRAWING ORDER	TITLE	HORIZONTAL SCALE	VERTICAL SCALE
Collection			
	Subsystem Block Diagrams	No Scale	
	Equipment Arrangement Plans Facility Layout Plans	1"=40' 1"=20' (If used on electrical drawings)	
	Installation Details/Bill of Materials	As Required	
	Conduit and Cable Schedules	No Scale	
	Standard Drawings		
Systems Integration			
	Abbreviations, Symbols and General Notes	No Scale	
	Subsystem Block Diagrams	No Scale	
	Functional Block Diagrams	No Scale	
	Riser Diagrams	No Scale	
	Equipment Arrangement Plans Facility Layout Plans	1"=40' 1"=20' (If used on electrical drawings)	
	Installation Details/Bill of Materials	As Required	
	Conduit and Cable Schedules	No Scale	
	Standard Drawings		

1.6.7 Passenger Stations

One-inch-long dashed lines, separated by a 1/8" space, shall show the outline of transit passenger stations.

Track lines shall be shown continuous through the passenger station. The station shall be titled "XXXXXX Station" in or near the passenger station outline using 7/32" high letters. However, to reduce congestion on the drawing, the Mainline Route Schematic (SY-H-001) shall not include the word "Station" in station titles.

Pavement lines shall identify streets and highways adjacent to transit lines. Lettering for street names shall be 1/4" high.

1.6.8 Match Lines

Use cell format SCRRA MAT1, SCRRA MAT2, SCRRA MATL from SCRRA General Cell library, refer to [Section 1.3.11](#) and [Figure 1.6](#). For matchline label text and weight size shall be in accordance with [Table 1.0](#).

1.6.9 Column Line Designations

Column line designations in building plans shall be designated by numbers and upper-case letters omitting the letters I, O, and Q. Orientation for numbers shall be left to right with letters to be top to bottom. Station drawings developed from standard modules may



use an alpha numeric combination with the letter prefix identifying the module and the column lines within the module identified by number.

1.7 DIMENSIONING

1.7.1 General

- A. Requirements for dimensions include the dimension text, arrowheads/line terminators, the dimension line extending between the arrowheads and the witness lines extending from the ends of dimension lines to the measured element.
- B. Scaled dimension lines shall be simple, straight, unbroken lines, with arrowheads. Refer to [Figure 1.14](#).
- C. Dimension Arrowheads/Line Terminators shall be filled, 1/8" long x 1/16" wide in standard "D" size drawing. Use AC=SCRRA_AHT for arrowheads from SCRRA General Cell library.
- D. Dimensions shall be exact unless noted to the contrary with the abbreviation "Approx." or the symbol "±" appearing immediately after the dimension.
- E. Care shall be taken to avoid duplicate dimensions. One dimension indicated as typical (TYP) is recommended. Only those dimensions required to construct or inspect the work shall be included. The drawing shall not be cluttered with superfluous and repetitive dimensions.
- F. Dimensions shall be shown to definite points only. Dimensioning to rough cast surfaces or to grade shall be avoided. In this case, elevation instead of the dimension shall be used (e.g., Elev. 37.25).
- G. Features being dimensioned shall be drawn to scale. If for any reason a dimension is not to scale, "No Scale" shall be placed immediately below the dimension line and the line shall be broken on both sides of the dimension figure.

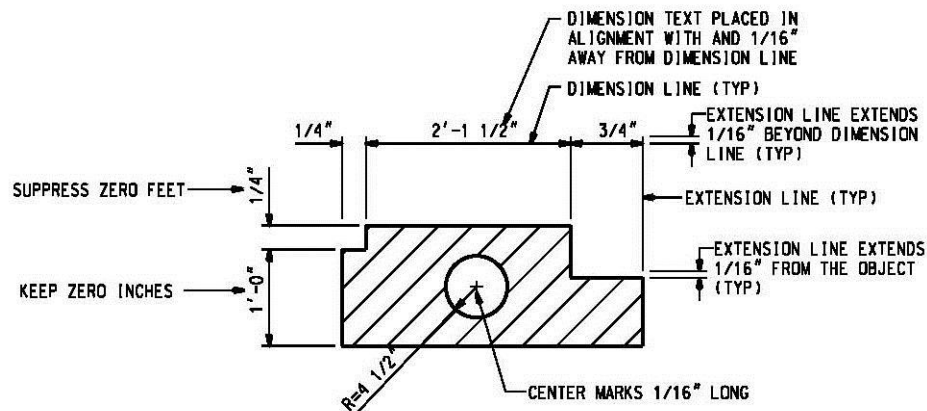

Dimensions in Feet and Inches

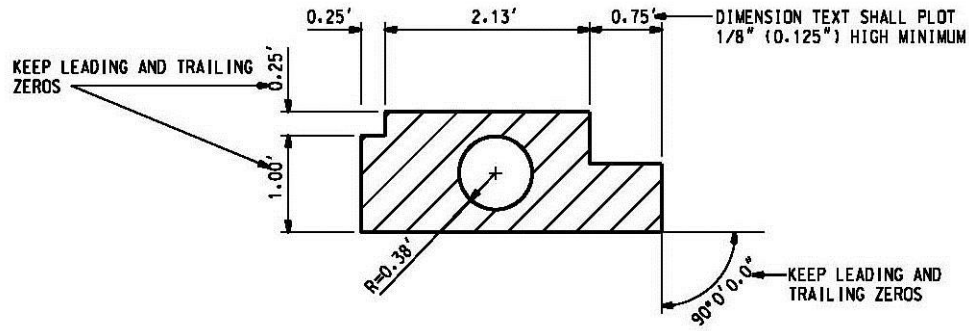

Dimensions in Decimal Feet

Figure 1.14 Dimensions

1.7.2 **Location of Dimensions**

- A. All dimension figures and notes shall be placed above the dimension line when read from the bottom or right edge of the sheet and inside the witness lines. Placement of dimensions outside the object is desirable. However, in the interest of clarity and simplicity, it may be necessary to place some dimensions within the object.
- B. Dimensions of like objects on any one part of a drawing shall be lined up in chain fashion (e.g., equipment, centerline, column centerline, etc.). Dimension to match line if match line is not located on a column line.
- C. Longer dimensions shall be placed outside of shorter dimension lines to avoid crossing of lines. [See Figure 1.14.](#)

1.7.3 **Units of Measure**

- A. Units of measure shall be consistent for all dimensions on a drawing. Examples of accepted dimensioning style in architectural/engineering (A/E) style of feet-and-inches are as follows:
 - 1. Overall Dimension 600'-0"
 - 2. Column Spacing 37'-6"
 - 3. Wall Thickness 10"
 - 4. Opening 1'-10 5/8"
 - 5. Clearance 118"
- B. When the decimal system is used for dimensions, elevations, alignments, stationing, angles, bearings, inverts, slope designations, etc., the number shall always be written to two decimal places. For coordinate system, the number shall always be written to four decimal places. If the number or slope is less than one foot, or one percent, a zero shall be placed in front of the decimal point. Slope callouts along all civil profiles shall include (+) or (-) sign in relationship to increasing stationing. Examples of the decimal system are as follows:



1. Dimension > 1' 37.50'
 2. Dimension < 1' 0.34'
 3. Slope < 1 % 0.36%
 4. Slope > 1 % 6.50%
 5. Elevation 654.54
 6. Coordinate N 441,646.1468
 7. Stationing STA AR 872+46.34
 8. Angles 73°26'20"
 9. Bearings N 16°27'32"E
- C. Reinforcement spacing shall be specified without the inches abbreviation, e.g., #4 @ 18.
- D. Project drawings shall employ the dimensional systems for specific drawing items as noted below:
1. Civil and Utilities Drawings - The decimal system shall be used for coordinate systems, elevations, gradients, points on horizontal and - vertical alignments, survey information, inverts, and slope designations. The feet-and-inches system shall be used for all other purposes.
 2. Structural, Architectural, Mechanical, and Electrical Drawings - The decimal system shall be used for specific elevations and the feet-and-inches system for all other layout dimensions and details.

1.8 SECTION, DETAIL AND ELEVATIONS DESIGNATION

Refer to [Figure 1.15](#) - for Section sample; Detail sample, and Elevation sample. These designations shall apply to all engineering and architectural drawings.

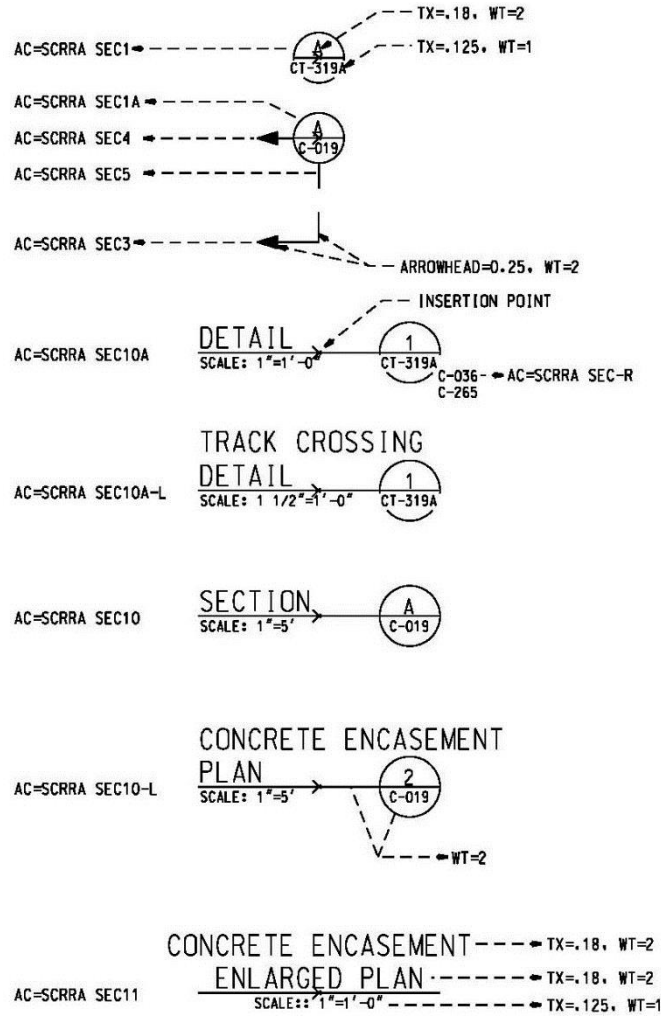

NOTE: ALL TEXT ARE ENTERED ON THE CELL DATA ENTRY AND MUST BE ON LEVEL 45

Figure 1.15 SCRRA Cell for Detail, Elevation, Plan, Profile and Section Titles

1.8.1 Sections

A. Rail Sections

1. Nomenclature:

Transit line sections, including earthwork sections, shall be referred to as cross sections.

2. Identifying Symbols and Titles:

These sections shall not be cut on the plan but will be identified by station title as follows: STA AR 327 + 00

3. Orientation:



Cross sections shall be arranged looking ahead on line, i.e., in the direction of increasing stationing. When more than one cross section is drawn on one sheet, the cross sections shall be arranged so that the section stations increase from the top to the bottom of the sheet and from left to right.

B. Engineering and Architectural Sections

1. The standard symbol which is located in the SCRRA General cell library, shall be used for marking where sections are cut and shall be included in the Standard Abbreviations, Symbols, and General Notes Drawings.
2. Sections shall be selected to show comprehensive information but without repetition. Section cut symbols on [Figure 1.15](#) on plans or details of a view at one scale need not be repeated on plans or details of the same view at smaller scale. Section views shall be ordered in a plan set according to the level of detail, large scale to follow small scale sections.
3. The upper portion of the circles used in both the section identifier symbol and section title, contains the alphabetic character identifying the section. The lower portion contains the drawing number of the sheet on which the section is drawn.
4. Sections shall be lettered consecutively: A,B,C, etc., omitting I, O and Q starting from the top left to the bottom left and from left to right on the sheet, see [Figure 1.16](#).

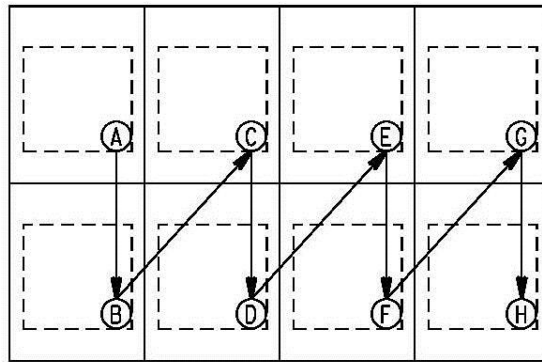

Figure 1.16 Detail, Section and Elevation Presentation

1.8.2 Details

A. General

Details shall be selected to show comprehensive information but without repetition. Detail symbols shown on plans, sections, or details of a view at one scale need not be repeated on plans, sections, or details of the same view at smaller scale. Detail views shall be ordered in a plan set according to the level of detail, large scale to follow small scale details.



B. Identifying Symbols and Titles

The standard identifying symbol and detail title shall be used for engineering and architectural details and shall be included on the Standard Abbreviations, Symbols, and General notes sheet for each discipline:

1. The limits of a detail shall be defined by encircling the subject area and placing a leader line from the encircling figure to the detail identifier symbol.
2. The upper portion of the circles used in both the detail identifier symbol and detail title, contains the numeric character identifying the detail. The lower portion contains the drawing number of the sheet on which the detail is drawn.
3. The numbers of all drawings on which a detail identifier symbol is used shall be listed under the title line and to the right of the detail title.
4. The orientation of a detail shall be identical to the plan, elevation, etc., to which it is referenced.
5. Detail shall be numbered consecutively: 1,2,3, etc., starting from top left to bottom left and from left to right on the sheet, see [Figure 1.15](#). junk

1.8.3 Section, Details and Elevation Designation

- A. Designation of section and elevation cuts shall be with straight lines. Extension lines need not be continuous across the extent of the section/elevation if the intent is clear. Detail call-outs shall be consecutive and designated by numerals (1, 2, 3, etc.). Sections and elevations shall be consecutive and designated by upper-case letters (A, B, C, etc.), omitting the letters 1, 0, and Q. After all letters have been utilized, two letters shall be used, such as AA, AB, AC, etc. Letters and numerals may reappear within the same discipline or group of drawings as long as these letters and numerals are on different sheets, see [Figure 1.15](#).
- B. When a subassembly or component is shown in outline or by symbol, an arrow note indicating the type of subassembly or component and the drawing on which it is shown in its entirety may be used.

1.8.4 Symbol Designation

- A. The designation of section, detail, or elevation (A, B, etc., or 1, 2, etc.) shall always be shown in the upper half of the circle. The drawing number on which it is drawn shall be shown in the lower half, if not detailed on the same sheet. On the sheet where the section or detail is drawn, all the sheets where the section or detailed is identified shall be shown outside the circle, below the line and to the right, see [Figure 1.15](#).
- B. In the case where the section, detail or elevation is cut and shown on the same sheet, show only a 1/4" long dash inside the lower half of the circle.



1.8.5 Similar Sections

- A. When a section or detail is similar to one already shown, either on the same sheet or on a separate sheet, the new section or detail need not be drawn but may be referred to in the existing sectional view by stating that the new section is similar.
- B. The word "SIMILAR" (abbreviated to SIM), where clarification is required, shall be expanded to explain how it is similar, such as "SIM, BUT OPPOSITE HAND" (abbreviated OPP HAND) or "SIM EXCEPT AS NOTED." In designating a similar section, always use a different letter, as B above, and not the initial letter with an accent: e.g.; A. Do not use the word "SAME." Use parentheses to distinguish items/dimensions that are similar.



2.0 CADD GUIDELINES AND CRITERIA

2.1 PURPOSE

The purpose of this section is to establish guidelines for all CADD work performed by SCRRA Construction Project Management Division, engineering consultants, contractors and subcontractors.

2.2 CADD QUALITY CONTROL

All plots and electronic CADD files produced by the engineering consultant, its subcontractors and SCRRA staff shall be in accordance with these CADD guidelines and criteria. Consultants providing data shall have an approved quality control program to assure compliance of team member data for interim submittal and final delivery of data.

All data submitted to SCRRA not conforming to standards as described herein shall be returned for correction. Interim submittal files shall be corrected prior to the next submittal. Where checking indicates procedural problems, the consultant shall take immediate remedial action and resubmit files prior to next submittal. Rejected final submittal files shall be fixed and returned within one week, or two weeks if a program format other than MicroStation has been approved and pre-processing such as translation is required in correcting the problem.

Because of the nature of evolving computer technology, software program changes or up-dates may affect specific requirements of these standards or the procedures for managing data. Consultants shall review changes in requirements received during the course of design and advise of cost and schedule impacts on a contract. Changes impacting cost and schedule shall be executed according to written instruction provided by the Director Engineering and Construction.

2.3 SOFTWARE

The preferred CADD software program is Bentley Systems' MicroStation V8i (or latest). Upon approval by SCRRA, CADD Programs and advanced applications other than MicroStation V8i may be used in developing contract drawings. All CADD electronic file submissions during design and after completion of drawing packages shall be delivered to SCRRA in MicroStation V8i ".DGN" file format. Any translation and processing required for compliance with the accepted file format shall be the originator's responsibility. Plotted ".DGN" files shall be quality control checked before drawings package submission to SCRRA.

The MicroStation electronic file requirements set forth in this manual include but are not limited to the following:

- Active and reference file structure and settings
- File names
- Working units
- Global origin
- View attributes and settings
- Leveling and symbology
- Text attributes



- Coordinate readout
- Dimension geometry, attributes and units
- Line weights set according to the SCRRA pen tables
- Cells and cell libraries

Bentley Systems, Inc., as well as a number of third party developers also offer advanced application software packages with utilities that automate design and drafting. Some examples of the Bentley advanced products are provided in the following list:

- InRail
- InRoads
- Rail Track
- Auto Turn
- IRASB
- MicasPlus Model Draft
- Microstation GIS Environment (MGE)
- ModelView
- Project Architect (PARCH)
- Project Engineer Electrical (PE-ELEC)
- Project Engineer HVAC, (PE-HVAC)
- Project Engineer Pipe (PE-PIPE)
- Project Layout (PLAYOUT)
- RoadWorks
- Design Works

Many of these programs generate useful supplemental data and parameter files and the SCRRA may require designer to submit them with the CADD data. SCRRA will provide any such data generated by in-house work for consultant use. The use of such applications must be clearly documented to realize of the benefits of exchanging supporting data.

2.4 HARDWARE

The SCRRA hardware includes Intel based Windows platforms. Other platforms are accepted, provided the data delivered is compatible with the indicated formats. File transfer hardware includes CD read/write equipment. In-house plotting is done on half size laser printers and full size black and white InkJet plotters. All submitted data will be verified using SCRRA hardware and software.

2.5 DRAWING TYPES

CADD drawings are categorized into two major types - geographical and non-geographical oriented.

Geographical oriented drawings are those produced by civil, right-of-way, trackwork and utilities disciplines and map on a one-to-one basis between these disciplines. Drawing files of physical elements shall be based on the California coordinate system. Geographical drawing files shall all have common working units and a global origin.

Non-geographical drawings consist of plan, building, or model files wherein the drawing elements describe the spatial relationship of plans, elevations and sections with



reference to monument points established for each project. These are generally not based on the California coordinate system. Disciplines utilizing these non-geographical drawings are Architectural, Structural, Systems, Mechanical, and Electrical. All non-geographical files within a contract shall use the same monuments, have a common global origin, the same working units and shall map on a one-to-one basis between disciplines.

Each project shall establish saved views in key drawing files, with at least two common reference points, for the purpose of attaching geographic to non-geographic reference files as described herein in the paragraphs on Structuring Project Files.

2.6 FILE ORGANIZATION AND REQUIREMENTS

2.6.1 Three Dimensional Files

All CADD data delivered to or developed by the SCRRA as part of a project submission shall be MicroStation 3-dimensional (3d) files.

In projects and files that do not require 3d information users can continue to work in 2d as before, but in a 3d file, if the parameters are set correctly in 3d files. This can be done automatically at creation time by configuring the seed file. The setup is as described in the following:

- A. Set Display Depth to 10,000 by keying in dd=-10000, 10000
This setting opens the display cube to allow you to see any elements that may have been placed in the design file outside of the display setting.
- B. Set boresite lock "ON".
This setting allows location of any element that lies near a boreline at the position of the pointer. With Boresite Lock turned off, only elements near the active depth can be located.
- C. Set all views to "TOP"
Since the file has no Z values, work only in the TOP view.
- D. Set Active Depth to "0" (ad=0 and select view 1)
This command sets the default drawing elevation to "0" which will help to locate the elements at "0" elevation.
- E. Set ACS Plane Lock to "ON"
This setting when turned on, forces each data point to lie on XY plane at the active auxiliary coordinate system, setting all Z coordinates to zero.
- F. Set ACS Plane Snap Lock to "ON"
This setting forces MicroStation to find the projection of a snap point on the active depth XY plane, whether or not the object point snapped is on the XY plane. This is critical when snapping to points on reference files that may be at a different elevation, and will prevent the accidental drawing of objects that appear 2d in the top view but in reality extend from one plane to another in the side or isometric view.



2.6.2 Contract Files

These are plottable files representing a contract drawing. Each contract file shall contain only one contract drawing and is identified by the file name and extension as described in [Section 2.7](#), File Naming Policies.

Contract files typically shall contain only sheet dependent information, such as title block information, north arrow, notes, matchlines, dimensions, labels, etc. Other information and the border should be contained in attached reference files, see [Figure 2.0](#).



Figure 2.0 Model Active File

2.6.3 Logicals

When attaching reference files, use consistent logical lower case names as suggested in the following table:

<u>Logical</u>	<u>Description</u>
bdr	Border File
key	Key Plans
gen	General Files (notes, indexes, schedule, etc.)
arc	Architectural Files
civ	Civil Files
ele	Electrical Files
mec	Mechanical & Plumbing Files
row	Right-of-Way Files
utl	Utility
str	Structural Files
sym	System Files
sur	Survey Files
geo	Geotechnical a,b,c,d, etc. Temporary Reference, only

Add number suffixes to logical names if the same reference file is attached more than once or if more than one reference file of the same type is attached.

2.6.4 Border File

The consultant/contractor shall use a single border file per Contract with one “Model” to show Discipline/Consultant data information for contract drawings, refer to [Section 1.5](#).

Level/layer assignment on Border file will follow AIA layer guidelines, sample of General level/layer names are shown on [Figure 2.1](#). For all discipline National CADD Standard level/layer names refer to [Appendix 6](#) and for SCRRA discipline level

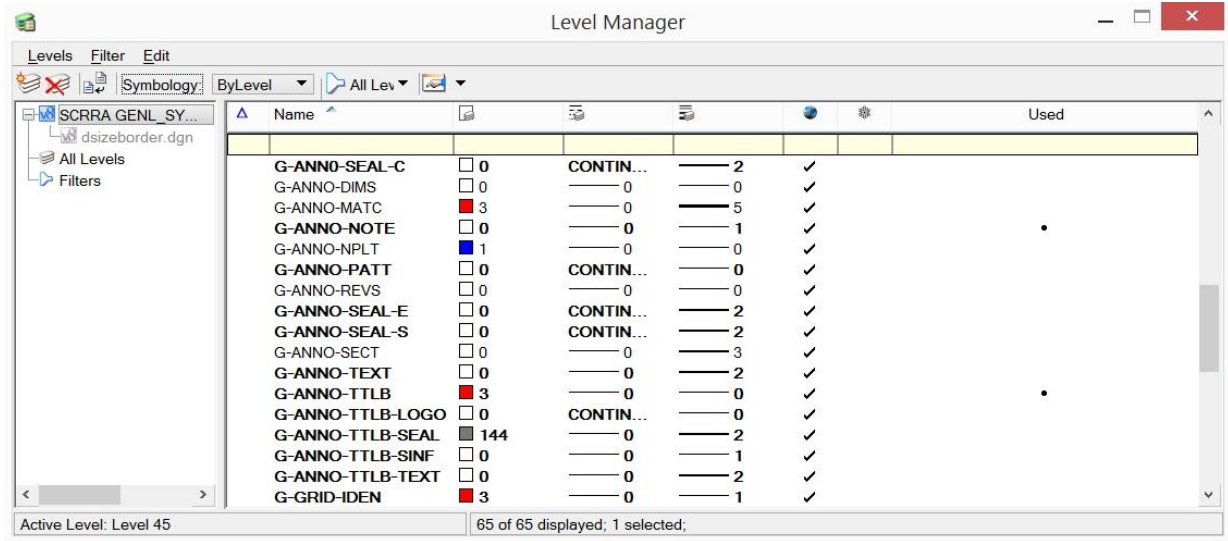

Figure 2.1 General Level/Layer File

All contract files shall attach the standard SCRRA border file described in the following. The SCRRA border file shall not be modified. The features and method of using the border file is described in the following:

The standard SCRRA border file has been created with special working units, 16 sub-units per master unit, and 500 positional units per sub-unit (1:16:500). With this arrangement, the scale factor used in attaching the border file corresponds numerically to the scale of the drawing to be plotted.

For example, an engineering drawing to be plotted at a scale of 1"=40' would be attached at 40:1. An architectural drawing to be plotted at 1/8"=1'-0" would be scaled at 8:1.

Architectural	Plotted Scale	Scale Factor
	3/8"=1'-0"	8:3
	3/16"=1'-0"	16:3
	3/4" = 1'-0"	4:3
	1-1/2"=1'-0"	3:2
	3"=1'-0"	1:3
	6"=1'-0"	1:2
	1/4"=1'-0"	4:1
	1/16"=1'-0"	16:1
	1/8"=1'-0"	8:1
	1/2"=1'-0"	2:1
	Full Scale	1:12

Engineering	Plotted Scale	Scale Factor
	1"=2'	2:1
	1"=5'	5:1
	1"=10'	10:1
	1"=20'	20:1
	1"=30'	30:1



1"=40'	40:1
1"=50'	50:1
1"=100'	100:1
1"=200'	200:1
1"=500'	500:1
1"=800'	800:1
Full Scale	1:1

2.6.5 Seed Files

Only approved discipline seed files (template files) are to be used when creating working design files and sheet files. By standardizing file design settings according to discipline standards, each user within a discipline and project will enter a file which is uniformly predictable.

Time will not be lost setting the environment, attaching cell libraries, adjusting display controls, dimension display, view attributes, etc that should be standard within disciplines.

Seed files for both geographic and non-geographic files should be set up in advance. The principle difference is in the settings for working units and for global origin as discussed in [Sections 2.6.6](#) and [Section 2.6.7](#).

The settings of the Microstation 3d seed files provided to consultant/contractor are described in the following:

Active level (LV)	1
Active weight (WT)	1
Active line code (LC)	0
Active color (CO)	0
Active scale (AS)	1
Active angle (AA)	0
Active Z-depth Absolute (AZ)	0
Levels displayed	1-63
Unit round-off (UR)	:0.0625(1/16")
Grid round-off (GU)	:0.125(1/8")
Grid reference (GR)	12
Text Height (THE-)	:0.125(1/8')
Text Width (TW)	:0.100
Stacked fraction	On
Line spacing (LS)	:0.0625(1/16")
Line length (LL)	225
Font (FT)	1
Text justification	LT
Text node justification	LT
Set PARSEALL	Off
Locks on	Keypoint Snap



Fence mode	Inside
Fast display:	
Fonts	Off (all views)
Cell	Off (all views)
Text	Off (all views)
Curve, arc, ellipse	Off (all views)
Other display attributes:	
Weight	On (view 1-7)
Pattern	On (all views)
Text node	Off (all views)
Enter data fields	Off (View 1 only)
Level symbology	On (all views)
Dimensional data	On (all views)
Construction lines	On (all views)
Fill	Off (Views 1 & 5 only)
Grid	Off (all views)
Display depth	-5000 to + 5000
View controls:	
Delay (if applicable)	All screens
Views on	Views 1, 5-8
Overview	On
Raster view controls:	
Drag	Off
Pan	Off
Cell library attached	scrra general.cel
Reference file(s) attached	none
Windows:	
Overall view (entire contents)	View 1 optional
Logos	View 7 optional
Sheet or file information	View 8 optional
Plot View (vi =plot)	View 5 required
Engineers' signatures	View 6 optional

Settings for 3d files to contain 2d information only as discussed in [Section 2.6.1](#):

Display depth	-10000,10000 (all views)
Boresite lock	On
Views	Top (all views)
Active depth	0 (all views)
ACS plane lock	On (all views)
ACS plane snap lock	On (all views)



2.6.6 Working Units

Working units are the real world units assigned to the design plane. Working units settings designate the working units and working resolution. Microstation V8i uses IEEE 64-bit floating point storage, which allows for a high degree of accuracy and a working volume with each axis roughly 2 million time larger than the axes in V7.

Working units for all CADD files prepared by the Designer shall be as follows:

Non-Geographical disciplines (Architectural, Structural, Mechanical, Electrical)
Master Units (MU) 1(')
Sub Unit (SU) 12 (")
Positional Units (PU) 2,032 (positional units per sub unit)

Geographical disciplines (Civil, Right-of-Way, Utilities)
Master Units (MU) 1(')
Sub Unit (SU) 10
Positional Units (PU) 1,000 (positional units per sub unit)

Border
Master Units (MU) 1(')
Sub Unit (SU) 10
Positional Units (PU) 1000 (positional units per sub unit)

2.6.7 Global Origins

All engineering work (Mapping, Civil, Right-of-Way, Utilities) shall be based on California Coordinate System, Zone 5 and Zone 6, North American Datum (NAD '83). As defined by the National Geodetic Survey (NGS). The vertical datum for all mapping, planning, design, right of way engineering and construction on all involved transportation improvement projects, including shall be the North American Vertical datum of 1988 (NAVD88), as defined by the National Geodetic Survey (NGS).

Below, Figure 2.1 is the latest graphic from Caltrans Zone 5 and Zone 6 which SCRRA will be using to create all seed files.



Table with 3 columns: ZONE, X CENTER, Y. Row 1: 5, 6561666.667, 2095707.846. Row 2: 6, 6561666.667, 2065126.163.

Figure 2.1 Caltrans Zone 5 and Zone 6 (NAD 83)



2.6.8 Structuring Project Files

A. General

Use of reference files is important for efficient use of CADD and in assuring coordination both within a discipline and between disciplines. This is particular importance in transit projects where interrelated components are designed by different teams under separate contracts.

B. Contract Drawing Files (Sheet Files)

While detail structuring of project files must be determined based on the particulars of a project, guidelines have been established for all SCRRA project files. These are dependent on the content and the type of file.

Contract drawing files contain all notes, labels, dimensions, notations, match lines and reference symbols as active elements entered at the plotting scale if inserted on Model space. The border file must be attached as a scaled reference file, see Section 2.7.5). Additional information is provided in attached reference files, or as active data as contained in index, schedule, and detail drawings.

C. Station and Building Design Files (Reference Files)

Graphic information in plans, sections, and elevations shall be contained in reference files that are used by all design team members. Reference file usage assures that information is identical for all team members and that changes are immediately reflected. Copying reference file information into a design file shall be avoided since association with the copied file is lost.

Similarly within a discipline, files should be structured so that large scale detail information can be added to clipped portions of the design file plan, section, and elevation information. In this way, changes in the basic information are reflected throughout the contract set.

Attaching the associated files of other team members provides continuing coordination between architectural, electrical, mechanical, structural and other disciplines as well as systemwide contract components.

Alignment information and primary site information such as streets, curbs, property lines, and site features that are included in station or building drawing files should be shown by attaching the appropriate civil drawing reference file where such information is established.

D. Reference File Attachments

Inter-discipline plan, elevation and section files shall be attached without scale and without repositioning, or reorientation.

E. Geographical Design Files

1. All discipline design files have the following characteristics which influence production strategies.

a. The location of objects with respect to ground coordinates, or some other user defined coordinate system is critical.



- b. Projects may cover vast areas of land with varying needs for displaying the project at different scales for different purposes.
 - c. Large amounts of data (easily exceeding the size of the data required to address the design problem) may be used to indicate existing conditions. Over the life of a project the existing conditions may change, requiring old information to be replaced with new.
 - d. Production teams may work simultaneously on one project. These teams may be from different firms, and may use different computer hardware and software.
 - e. Disciplines, may at times use highly efficient symbolic representation of their work, At other times the representation is literal.
2. Geographical disciplines should adopt the following production procedures to accommodate the above characteristics.
- a. Maintain access to the Ground Coordinate system for the life of the project and in all contract document files.
 - b. All graphical drawing data should be organized by major types and drawn at a 1 to 1 ratio in a master file. Some examples are horizontal alignments, vertical alignments; street plans showing sidewalks, curb and gutter lines; utility information such as storm drains, sanitary sewer lines, gas lines, water lines, and right-of-way plans showing property lines, etc.
 - c. All drawing text shall be placed in contract drawing files except where the identical text is repeated in a number of contract drawings. Users may include text at appropriate scale in the reference file attached to the contract drawing files. When attaching design files to the contract document drawings the user shall not scale, move or rotate the master files. If a rotated plot view is required the user shall attach the design file coincidentally and then rotate the plot view to match proper project and plot orientation. The plot scaled border shall be attached in the rotated view. All reference file clipping shall be done in this view. All files referenced in a project must reside within a project directory at baseline to ensure a complete archive of the project. Each discipline shall list its drawings per contract and the reference files attached as well.

2.7 FILE NAMING POLICIES

2.7.1 General

All files must be named in a consistent and logical manner. File names must be coordinated between disciplines and design team members for each project. All files names shall be unique, alphanumeric and shall conform to the general naming rules.

File Name Components are the following:



Project Identifiers - are two character abbreviation of the Project Name. It will be defined and coordinated by SCRRA.

Sub-Project Identifier – used to break out files by contractors or sub-contractors. It will be defined and coordinated by SCRRA.

Discipline Designators – are one or two character abbreviations for the discipline that is responsible for the file.

Typical File Type Designators - are two character abbreviations for the type of file that is being created. For list of file types, see the User [Appendix 1](#).

Sheet Numbers - typically a two or three digit number. When used always include the leading zeros and keep the same number of digits on all files.

Revision Suffix – typically underscore (_) is use and one character, optional.

2.7.2 File Naming Procedures

Contract file names shall be developed and submitted for approval as soon as the contract drawing list for the project is compiled. The listing will include all drawings associated with a project design. Design filenames for each project shall be developed and coordinated with all members of a project design team. File name will use upper or lower case alphabetic and numeric characters.

The project CADD coordinator will regularly review reference file names developed by each design team to assure consistency and to avoid duplication Model File (Reference File).

2.7.3 Contract Number

For Contract Numbers, refer to [Section 1.5.3](#).

2.7.4 Model File (Reference File)

Filename shall consist of 10 characters maximum not including file type extension. A design may contain one or more models. The sheet file consists of references of the design models. Reference file includes geometry only and should not include any kind of notations and/or dimensions except design text. An example of design text is InRoads stationing. Refer to User [Appendix 1](#).

Standard: BK201CDP01.dgn represent as SB County, Rail 1, Civil Drainage Profile #1

Project Identifier	Sub Project Identifier	Discipline Designator	File Type Designator	Series Identifier	File Extension
BK	201	C	DP	01	dgn



2.7.5 Xref (External References)

Filename shall consist of 11 characters maximum not including file type extension. Xref files are created from the discipline specific Model file. All excess graphic information contained in the Xref files that is not pertinent to the individual drawing file shall be eliminated.

Entity definitions within Xrefs shall conform to the standards for layer/level, color, text, line types, etc. in accordance with [Section 1.6](#).

Standard: XBK201CDP01.dgn represent as SB County, Rail 1, Civil Drainage Profile #1

External References	Project Identifier	Sub Project Identifier	Discipline Designator	File Type Designator	Series Identifier	File Extension
X	BK	201	C	DP	01	dgn

2.7.6 Contract Drawing Files

Filename shall consist of 14 characters maximum not including file type extension. Contract drawing files are the files from which a contract drawing is plotted. Typically, these files contain notes, dimensions, labels, symbols, indicators and annotations, including title block. For contract files, the number following the discipline code will be the same as the contract drawing number represents.

All contract drawing files shall be identified by the extensions “.sht”.

Standard: BK201-C-DP-102_R.sht represent as SB County, Rail 1, Civil Drainage Profile Sheet 102_R (Revision placeholder)

Project Identifier	Sub Project Identifier	Discipline Designator	“-“ Hyphen	File Type Designator	Drawing Number	Revision Suffix	File Extension
BK	201	C	-	DP	102	_R	sht

Table 2.0 SCRRA Discipline Codes

Discipline	Contract Drawing	Directive Drawing
Architectural	A	AD
Automatic Train Control	Q	QD
Borings/Geotech	BG	
Civil	C	CD



Discipline	Contract Drawing	Directive Drawing
(Civil) Drainage	D	
(Civil) Drainage Profiles	DP	
(Civil) Drainage Details	DD	
(Civil) Drainage Quantities	DQ	
(Civil) Fencing	CF	
(Civil) Contour Grading	CG	
Civil Paving	CP	
Civil Retaining Walls	CW	
Civil Site	CS	
Civil Street Lighting	CL	
Civil Street Modification	CM	
Communication Signal Duct Bank	NX	
Communications / Telecommunications	N	ND
Composite Utilities	UC	
Control Surveys	W	WD
Demolition	DM	
Electrical	E	ED
Elevators and Escalators	H	HD
Existing Overhead Utility Plan	UO	
Existing Underground Utility Plan	UE	
Equipment	EQ	
Fiber Optic	FO	
Fire Protection	F	
General	G	GD
Geotechnical	B	
Illuminated Signs and Edge Lights	ZB	
Landscaping/Irrigation	L	LD
Life Safety	LS	
Mechanical/HVAC	M	MD
Overhead Contact System	OC	
Plumbing	P	PD
Reference Drawing	RD	
Right-of-Way	RW	
Seismic Detection	SC	
Signage and Graphics	ZA	
Soil/Geography	K	KD
Special Studies	J	JD
Staging Drawing	SG	
Storm Under Drain	UD	
Structural	S	SD
Structural Retaining Walls	SW	
Supervisory Control and Data Acquisition	SA	
Survey/Mapping	V	VD



Discipline	Contract Drawing	Directive Drawing
Trackwork	T	TD
Trackwork Plan and Profile	TP	
Trackwork Cross Sections	TC	
Auxiliary Power	AP	
Traction Power	TP	
Traffic Handling	TH	
Traffic Signal	TR	
Tree Removal	AR	
Tunnel	Y	
Utilities	U	
Utilities - Water	UW	
Utility Composite Rearrangement	UR	
Utility Cross Sections	UC	
Quantities	Q	

For additional discipline code designator, refer to [Appendix 1](#).

2.8 DESIGN FILE NAMES

Design file names or model files shall be keyed to general content. Since files for geographical disciplines are organized differently than those representing non-geographical structures.

2.8.1 Geographical and Non-Geographical Files

Rules for the contract number, discipline codes and for the file extensions are the same for geographical files as for non-geographic files. Filenames also include an alpha character to identify the file type (alignment, ROW, etc) and a number to differentiate each file of a given type. [Section 2.7](#) provides guideline for naming files.

Filenames for Geographical Disciplines

Contract Number	Discipline Code	Drawing Content	Number Sequence	Extension
C0XXX	c- (civil)	a – plan/alignment	Determined by project	.dgn
	r- (right of way)	b – background m – monuments g – ground survey t - aerial		
	t- (trackwork)	c - cross sections		
	u- (utilities)	e – elevations/long. Sections/right track or general f – elevations/long. Sections/left track k – key, index		



For Example:

Contract	Discipline Code (First Digit)	Discipline Code (Second Digit)	Drawing No.	Ext
C3001	C	G	001	.dgn

Numbers assigned in the filename following the discipline code are to assign order.

Filenames for Non-Geographical Disciplines

Contract Number	Discipline Code	Drawing Content		Module (if req'd)	Extension
		Number	Description		
2 chars	a- (arch)	001 to 010	Underground station plan levels	a	.dgn .opl .mod .col for column/ grid file
	e- (elec)	011 to 015	Surface, grade level, plaza, street plaza	b	
	m- (mech) Pf- (plumb)	016 to 029	At grade and aerial station and building plan levels	c	
	s- (struct)	030 to 039	Reflected ceiling plans	d	
			040 to 059	Station and building cross sections	
		060 to 079	Station and building cross sections	f	
			080 to 089	Station and building cross sections	
		090 to 109	Interior elevations		
		110 to 119	Stair and escalator detail plans		
		5. to 129	Stair and escalator detail sections		
		130 to 139	Elevator detail plans		
		140 to 149	Elevator detail sections		
		200 to 299	Room and area detail plans		
		300 to 999	As determined by project and discipline		

2.9 SPECIAL CONDITIONS

2.9.1 Multiple Sub-Contracts

In situations where several team members provide drawings by the same discipline in the same contract area, their reference drawing files must also be differentiated to prevent duplication of names. In these cases, a firm designation code must be appended



to the number code or the module code if the contract is developed in modules as described above.

2.9.2 Other Contract Reference Files

When contract information from other contracts or projects is included in a project, all “borrowed data” files must be copied into the project directories, and renamed with project file names. A project identity code shall append the number code to facilitate the management and updating of such files.

2.10 FILE EXTENSIONS

2.10.1 Design Files

Examples for acceptable design file extensions are listed below:

.opl	3-D master dgn for the whole station
.col	column grid, key maps and north arrow
.sht	3-D file for contract drawings
.dgn	3-D file for referencing (Master)
.mod	3-D file for models
.inf	3-D file for interference checking
.hln	hidden lines file

2.10.2 Other than Design Files

Examples for acceptable non-design file extensions are listed below:

.alg	InRoads geometry file
.bat	DOS Batch file
.cel	Cell library
.cmd	Command file for COGO
.dat	Data file
.doc	Documentation file
.dtm	InRoads digital terrain model file
.exe	Executable program
.fib	Font Library
.lis	Listing file
.mnu	Matrix Menu
.out	Output file
.par	Parameter file
.rpt	Report file
.scr	Temporary file (ok for deletion)
.skt	Schematic Sketch file
.tbl	Pen table or color table



.tdp	InRoads project file
.tmp	Temporary file (ok for deletion)
.ttn	InRoads TTN File
.txt	Text file
.ucm	User Command
.xin	InRoads V8i preference configuration file

2.11 LEVEL ASSIGNMENTS

All contract drawing files produced by or for the consultant/contractor shall conform to SCRRA leveling standard. Proper planning and execution of a leveling standard is essential for maximizing productivity and isolating types of graphical and textual information. Consultant/contractor discipline leveling assignments are provided in [Appendix 5](#) and [Appendix 6](#). Section Designers and other consultants preparing CADD documents for consultant/contractor shall follow SCRRA guidelines and the AIA Layer Guidelines in the preparation of a leveling standard.

From time to time, the SCRRA standard leveling assignments may be appended or adjusted. Such changes will not affect the previously approved section designer plans, unless a specific instruction is included.

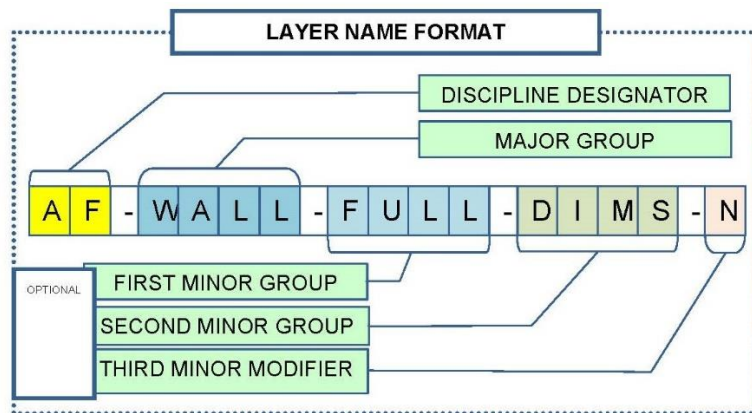

Figure 2.2 Layer Name Format

- AF Discipline Designator one or two character
- WALL Major Group four characters preceded by a dash
- FULL First Minor Group four characters preceded by a dash
- DIMS First Minor Group four characters preceded by a dash
- N Third Minor Modifier one character used to describe the Status Field Code as it relates to the items on that layer.



STATUS FIELD CODE	
P	Proposed Work
E	Existing to Remain
D	Existing to be demolished
F	Future Work
T	Temporary Work
M	Items to be moved
N	New
X	Not in Contract
1-9	Phase Number

For any additional level/layer name not listed on [Appendix 6](#), or AIA Layer Guidelines document, the designer should follow the “Layer Name Format” as illustrated on [Figure 2.2](#) for naming new level/layer and submit to SCRRA for approval. Cell Libraries

2.11.1 **Definitions**

The following list of definitions is included to clarify the discussion in this section:

A. Cell

A cell is a complex element composed of primary or other complex elements (in effect, a small drawing) that can be stored in a file, the cell library, for repeated use in one or many drawings.

B. Cell Library

A file which contains cells. This file can be simultaneously shared by any number of design files.

C. Universal Standards Library

The SCRRA General cell library contains all approved CADD cells and is maintained by engineering applications for all SCRRA projects. Modification of cells within this library is prohibited.

D. Shared Cell

Cells placed within a drawing file that all share a single graphic definition. Changing the definition of a shared cell changes all shared cells of that name within the drawing.



- E. Drop Status
The operation of disassociating the graphical components from their grouping as a cell.
- F. Terminator Cell
A cell used at the end of a linear element. The cell usually rotates to the angle defined by the last tangent section of the linear element.
LT = <Name>
- G. Pattern Cell
A cell used in a repeated application along a linear element. Cells can also be used in repeated applications to pattern a closed area.
AP = <Name>
- H. Point Cell
A cell that assumes the active symbology upon placement and is view independent.
PT = <Name>
- I. Graphic Cell
A cell whose symbology is determined when created and is view dependent (rotates with the view of which it is a part).
- J. Discipline-General Cell Library
The common cell library unique to each discipline which contains cells not included in the Universal Standards Cell Libraries.

2.11.2 Categories

Cell libraries are developed to promote efficiency and consistency in the design process. Complex graphic symbols and elements could be saved in the cell libraries and reused in the future.

Three type of cell libraries have been identified:

- A. The *Universal Standards Cell Library* contains cells that conform to SCRRA programwide drafting and CADD standards.
- B. The *Discipline Cell Library* contains cells that are specific to a discipline, conform to SCRRA programwide drafting, and CADD standards. The cells are compiled into a single cell library for each discipline such as electrical or mechanical. Cells included in these cell libraries may be used in any projects.
- C. The *Project Cell Library* contains cells that are specific to a project (such as Signage & Graphics). This have limited application and are compiled and maintained by the CADD leaders.



2.11.3 Cell Library Names

Cell libraries shall follow a uniform naming convention and be maintained in a central directory in order to maximize efficiently, avoid repetition, and provide a consistent user interface.

Suggested naming convention for the three types of cell libraries mentioned above are further described as follows:

- A. Universal Cell Library – SCRRA General.cel
- B. Discipline Cell Library:

Naming for this type of cell library should be simple, straight forward and easy to understand. Cell library name should contain no more than 6 characters on discipline description with “.cel” extension.

Examples:

SCRRA Elect.cel	Electrical Discipline Cell Library
SCRRA Civil.cel	Civil Discipline Cell Library
SCRRA Util.cel	Utility Discipline Cell Library

- C. Project Cell Library:

Contains project specific cell such as key map, section designer logo, etc.

Example: Cell Library = BK201e_C3001.cel

BK Project
 201 Sub Project/Project Number
 e Discipline “e” for electrical
 _ space under bar “_”
 Contract Number for contract number C3001

2.11.4 Cell Names

Project Cell names will be unique and shall follow a uniform naming convention. It shall be maintained in a central directory in order to maximize efficiency, avoid repetition and provide a consistent user interface.

2.12 DIMENSIONING

In addition to the dimensioning parameters established in [Section 1.7](#), the following shall be adhered to by all designers:

- A. Dimension Text Height (TH) = 0.125" (1/8")
- B. Dimension Text Width (TW) = 0.100"
- C. Weight of Text, WT = 1
- D. Text Font, FT = 1
- E. Weight for Dimension/Witness Lines = 0



- F. Terminator Width/Length = 0.125" (1/8")
- G. Terminator Height = 0.063 (1/16")

2.12.1 Dimension Style

To insure consistency of usage of different dimension style, use the SCRRA pull down menu to automate placing Civil, Right-of-Way, Utility and Track dimensions. Microstation location: Settings>manage>scrra_10_1000.stg. This file is located at "your_drive\scrra\standards\data".

2.13 TEXT

2.13.1 General

Text requirements for notes, dimensions, titles, and headings, shall be standardized for CADD usage. All text is to be input accurately and placed in the design file for legibility. The style and weight of text shall conform to standards and to the lettering requirements contained in [Section 1](#), Presentation and Drafting Guidelines. Fitted text is not recommended. The use of enter data field is encouraged wherever possible, including use inside cells. All text shall be uppercase with lowercase utilized only in approved symbols and abbreviations (primarily periodic table symbols).

Use the SCRRA pull down menu and follow the prompts to automate placing text. "SCRRA>Set Drawing Scale / Text Size –English".

2.13.2 Justification

Left-top justification is the default text justification setting and is used in the majority of cases. Center-center text justification shall be used for: five-line title in the title block, contract number, sheet number, revision number, title for individual details and circular or elliptical elements requiring text.

2.13.3 Fonts

Standard fonts commonly used in MicroStation drawings are font #1, #3, #8, #43, and #94. Font #1 (a proportional font) shall be used for all notes, dimensions, general notations, title blocks and elsewhere when another font is not specified.

Font #3 (a non-proportional font) shall only be used in those schedules, tables, drawing indexes where items require text to line up.

Font #8 (Helvetica Medium) may be used for special projects such as signage and graphics where an accurate representation of the intended signage is required.

Font #43 (a non-proportional font) shall only be used in match line text, it also may be used in cells and schedules.

Font #94 (a symbolic font) is used by the vertical application of In-Roads and consist of a circle and a triangle.

No other fonts shall be utilized in the preparation of drawings without prior authorization from SCRRA, refer to [Table 1.0](#).



2.13.4 Text Sizes

There are five standard text sizes to be utilized by and for the SCRRA when preparing all required CADD drawings. Text size height values are based upon finished full size plot of 22"x34", as specified with these criteria as shown in Figure 1.8.

Exception: Text used for existing elevations in civil topographical backgrounds prepared by others shall be 0.10" in height, weight equal to zero (0) with no text width re-scaling. Text height to text width ratio shall be one to one.

All CADD drawing graphics shall be created at full size (1 to 1 ratio). They are scaled at the time of plotting. It is very important to place text at an appropriate CADD size within the drawing based on the intended scale of the plotted drawing. Example: For a 1"= 40' plot scale drawing, 1/4" size text shall be ten feet (10') tall in graphics size.

Text height and width values are keyed in by using the TH = and TW = commands to facilitate placement of text. The ratio of text width (TW) to text height (TH) shall be 80%. Example: 1/8" text(TH=0.125", TW=0.100")

Line spacing shall equal to one half the overall height of the text.

$$LS = .5 \times TH$$

2.13.5 Text Color

Text colors such as black, brown or dark blue shall be avoided. For standardization across all disciplines, text colors are restricted to Microstation green (CO=2) and white (CO=0). Standard Microstation green (CO=2) shall be used for general notations, dimensions, and their associated graphic elements. Schedules and index text shall be Microstation white (CO= 0). Refer to [Appendix 3](#).

2.13.6 Text Line Styles

All text shall be line style zero. Pen tables shall be utilized for any screening required for text.

2.13.7 Enter Data Fields

Enter data fields are to be utilized whenever feasible. Standard component and detail cells have enter data fields that are at the proper level, font, weight, color, size, and may be filled in with different information as required without having to drop the cell and edit text. Schedules and tables shall be structured to accommodate enter data fields. "Orphan" data fields outside of standard or detail cells shall be deleted from the design file whenever they are not utilized (check by using enter data field display on and deleting).

2.14 ELEMENTS

2.14.1 General

Each element (arc's, lines, line strings, shapes, etc.) placed in a design file shall conform to a pre-determined set of display symbology and level assignment.



2.14.2 Line Styles

MicroStation offers three ways of inputting line styles into a design file: line codes (LC's), line patterning, and custom line styles.

A. Line Codes

Eight standard MicroStation line codes are described as follows:

<u>Line Description</u>	<u>Code</u>	<u>LC=</u>
Solid	SOL	0
Dotted	DOT	1
Medium Dash	MEDD	2
Long Dash	LNGD	3
Dot Dash	DOTD	4
Short Dash	SHD	5
Dash, Dot, Dot	DADD	6
Long Dash, Short Dash	LDSD	

B. Custom Line Styles

MicroStation custom line styles are defined and stored in a line style library, "Symb" (Symbology) not in the design file. In order to reproduce the style on screen or in a plot, the library must be accessed. SCRRA-lstyle.rsc will be the standard line style library which eventually will contain all of the styles to be used by all disciplines. For this reason, designers who decide to customize a line style should save it as a file and submit for approval along with the project to SCRRA.

1. Parameters

Line style should be created at full-scale, wt=0, co=0, ft=l. Other parameters for line style stroke patterns are:

- corner: break
- shift: 0
- repetition: unlimited
- dash caps: closed
- length: fixed

Parameters for line style component point are:

- color: element
- weight: element
- justify: center
- rotation: relative

2. Scaling

Custom line styles are created at full size. Unlike coded lines (LC =), custom line styles must be inserted at a scale to match the plotted drawing scale.

3. Plotting



If line styles included in a design file are not defined in line style libraries, they cannot be plotted as a style. Design file style names not found in the libraries are plotted as solid line (LC=0).

C. Line Patterning (Linear Patterning)

An unlimited number of line patterns are available through the use of cells and linear patterning. The results for line patterning is unpredictable except for use in straight lines and shall not be used in place of custom line styles included in the standard line style library.

2.14.3 Line Weights

Microstation's line weights (WT=) correspond to the measurement of plotted line thickness using the system's standard pen tables. Seven line weight values are allowed. These values and plotted line thickness are shown as follows:

PLOTTED THICKNESS
11"x 17" 22"x 34"

<u>Weight (WT=)</u>	<u>Half-size</u>	<u>Full size</u>
0	0.0025"	0.0025"
1	0.0050"	0.0075"
2	0.0075"	0.0125"
3	0.0100"	0.0200"
4	0.0125"	0.0250"
5	0.0150"	0.0300"
6	0.0175"	0.0350"

Line weights above 6 may only be used for special purposes.

2.14.4 Color Table

Microstation color plot table will be provided by SCRRA.

2.15 PATTERNING

2.15.1 Linear Patterning

Linear patterning allow user to use a cell (AP=) as the pattern and applies the cell linearly along an element. Substantial time can be saved by utilizing proper patterning techniques.

2.15.2 Area Patterning

Area patterning allow user to use a cell (AP=) as the pattern and applies the cell to a closed chain, shape element or fence. Area patterning cells should be included both in the standard cell library and discipline cells libraries. Pattern used shall be added to the discipline Symbols Drawing.



2.16 SCREENING

For better presentation purpose, reference files may be plotted half-tone (screened) and served as background information. This can be done by modifying the level symbology of the reference file and adjust the color of the elements to color 112 (CO=112).

2.17 TERMINATORS

Terminators can be either point cells or graphic cells. Point cell terminators are provided for multilevel utilization, but should be utilized with the following limitations:

- A. Active Symbology (level, weight, color) is used for placement.
- B. Point cells line terminator viewed in a rotated view reflect original placement and orientation before the view was rotated and should not be used in rotated views.

Graphic cell terminators do not have the rotation/orientation problem, but do require original cell creation for level, weight and color to match project and discipline standards.

2.17.1 Line Terminators

Line terminators will be a filled arrow 1/16" wide x 1/8" long (2:1 ratio). Terminator will be scaled according to plot scale. Care must be taken when placing in rotated views.

2.17.2 *Leader Lines*

Leader lines shall be line string elements and composed of one vertex maximum. Leader lines for left or above termination, shall originate from the center of the uppermost text line, and for right or below termination shall originate from the center of the lower most text line, see [Figure 2.3](#). A minimum horizontal distance of 1/4" shall be maintained with a straight extension to object. Curved leader lines are not recommended. Leader lines and terminators shall be on the same level as required for general text notes and callouts. Leader lines may be broken when crossing dimension lines. Relocate the callout note or reposition the dimension, if possible, to keep broken leader lines to a minimum.

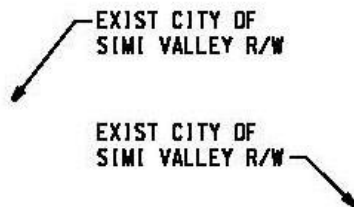

Figure 2.3 Leader Lines Placement

2.17.3 Pen Tables

Plotters require certain data to give definition to the way in which a particular line will be drawn on the plotter. The Pen Table determines how many strokes or dots that will be assigned to a particular line weight in the design file, and how many strokes or dots there will be for text at the same weight. The Pen Table also defines how those strokes will be made with each of the different weight pens.



In addition, the Pen Table can search the design file for certain special characters and replace them with such variable information as design drawing filename, plot time, and date and user names.

SCRRA has defined a standard Pen Table (plotstamp.tbl) for use by all disciplines. Other Pen Tables will only be allowed for plotting design files if prior approval from SCRRA is granted.

2.18 PLOTTING

All files must be created (or translated) to result in plotted drawings meeting all graphics presentation requirements. It is recommended to use the SCRRA_Printing.dgnlib for approved plot styles. Microstation project workspace should be configured to point to this “.dgnlib” file.

2.18.1 Batch Plotting

For Batch Plotting use the tool “Print Organizer” inside MicroStation. Print Organizer can be found at “File>Print Organizer”. This tool will allow you to save settings for repeat printing. Use of discipline folders within the Print Organizer is required. The advantages of batch plotting are as follows:

- A. Allows plotting outside of graphics
- B. Controllable plotting sequence
- C. Allows off-hours (unattended) plotting
- D. Multiple file plotting
- E. Standardizes output (full-size or half-size)

2.19 SUBMITTAL REQUIREMENTS

2.19.1 Guidelines

The following summarizes requirements for electronic files generated by the SCRRA or for consultant files to be incorporated in the SCRRA system. These requirements shall be consistent for all submittal.

2.19.2 Checking Procedures

This section addresses checking both the electronic format and contents of the project electronic files and the appearance of these drawings when plotted with the submitted CADD data using the plotting equipment and procedures. Electronic data shall be checked prior to submittals by in-house discipline leaders and the team CADD coordinator prior to submission. The plots produced from the data submitted by others shall be the basis for final acceptability of a CADD deliverable. The use of the “Standard Checker” utility provided with the Microstation V8i software is recommended,

The following is a checklist of the electronic data requirements checked prior to acceptance;



- A. Filenames

Verify that all CADD file names for contract files, master reference files, and drawing file extension follow the file naming requirements as indicated in [Section 2.7](#), File Naming Policies.
- B. Reference Files/Sheet Files

Verify that the proper signature (s)/names have been placed on all contract drawings prior to submittal.
- C. Leveling and Symbology

Verify that the leveling and symbology conforms to the approved project assignments. Non-conforming data will not be accepted by SCRRA.
- D. Contract Drawing File

Verify each contract drawing is represented by a single file.
- E. File Setting

Verify unused reference files are detached, named view plot exists (VI=PLOT), unused named views are deleted, file is compressed, working units and global origin are correct and consistent.

Verify the same view is used for display of the rotated or non-rotated fitted view of the drawing as displayed for plotting. This saved view name shall be called PLOT (SV=PLOT).
- F. Border

Verify that the border is included as a scaled reference file. Files with the border copied into the active contract file is not acceptable and will be rejected. All active border information shall conform to the approved hardcopy drawing information.
- G. Text

Verify conformance to text and dimensioning attributes both in drawings and in the data files submitted.
- H. Verify that cell names within drawing files are unique
- I. Signatures

Verify that proper signature(s) have been placed on all contract drawings prior to submittal.
- J. Line Style and Weights

Verify that line styles and weights of submitted drawings and of the drawings plotted from submittal data conform to the approved project plan for each discipline and to the general requirements of this manual.
- K. Cells



Verify that the graphic representation of cells within drawings conform to the established drafting and discipline standards.

L. Title Block Information

Enter all information specified herein in CADD except for the signatures in the “submitted” and “approved” lines in baseline submittal. In subsequent submittal of the drawing, verify that electronic signatures and initials from previous submission has been correctly keyed-in with CADD and that the note replacing the seal is in place.

2.20 CADD DATA IS A CONTRACT REQUIREMENT

These requirements have three primary objectives:

- A. To inform all parties’ consultant/contractor providing CADD data as a deliverable to the SCRRA of the Microstation format, style, symbology and naming requirements of such CADD data files.
- B. To inform all parties receiving CADD data from the consultant/contractor of the Microstation format, status, and limits of the consultant/contractor responsibility for CADD data and resources delivered to them.
- C. To advise all parties of the hardware and Microstation software requirements for the purpose of CADD data transmission to and from the consultant/contractor.

2.21 Backup and Archiving

All CADD, project, and system data files, shall be backed up and archived on a regular basis. SCRRA recommend Designer to perform a project archive every time immediately after a milestone submittal. Designer shall maintain all archive copies of the milestones submittal until the project is completed, accepted and signed-off by SCRRA.

Final Project Archive - After the project is accepted and approved by SCRRA, Designer shall perform a final project archive. It includes downloading all electronic data on CD, labeling all backup CD’s, and preparing a complete documentation showing the project name, contract number, short description of the project, backup creation date and the complete list of electronic data. This list should show the file name, short description of the file, date of last modification made, and file size. Should special plotting directions is required, it needs to be indicated in the documentation also. A full copy of this archive along with one set of hard copies will be submitted to SCRRA for review and approval.



3.0 REVISION GUIDELINES AND CRITERIA

3.0 REVISIONS

3.0.1 General

Changes to electronic drawings shall be executed in CADD and shall be re-plotted for issue so that the CADD files are always current with the record drawing hardcopy. Any deviation from this requirement must be authorized in writing by the SCRRA Director of Engineering and Construction, who shall confirm in writing that electronic revisions are executed and match the manual revisions in all particulars. Electronic data must be conformed to the manual changes in a drawing prior to the next revision.

All information contained in a re-plotted drawing not affected by the change must be identical to the previous issue of that drawing.

3.0.2 Applicability

These procedures pertain to the revision of standard, directive, and contract drawings once they are accepted as baseline by SCRRA. They also shall apply to amendments during the advertising period, to Change Notices after award of the contract and Project Record Drawings.

3.0.3 Approvals

All revisions to a contract drawing shall be executed under the supervision of the person sealing or approving the revision. See Section 1.8.2-J for responsibility of sealing the drawings.

Procedures for initiating and approving revisions to baseline drawings have been established as follows:

- A. Addenda revisions to contract drawings are initiated by request to the Project Manager who establishes the overall impact to the contract and coordinates the processing, approval and delivery to SCRRA.
- B. Revisions to contract drawings after issue for construction must be approved for processing in accordance with the Design Change Notice (DCN) procedures established by SCRRA. The Engineering Consultant or Engineer of Record coordinates the processing and delivery to SCRRA.
- C. Revisions to programwide standard drawings and directive drawings must be approved for processing in accordance with procedures established by SCRRA.

3.0.4 Revision Symbols

Revision symbols described below shall be placed touching each cloud circling a drawing change and in the revision blocks. Refer to SCRRA General Cell library for revision cell name, see User [Appendix10](#).

- A. During Design



Drawing notation for indicating design changes prior to sealing and signing shall be as determined by design management. All design change notation shall be removed in baseline drawings prior to preparation for advertising

B. Changes to Sealed and Signed Drawings Prior to Advertisement

Changes to sealed and signed drawing prior to advertisement shall be marked with an apex down 9/32". Each such change shall be clouded separately and identified by an alphabetic sequence of letter starting "A" inscribed in the apex down triangle.



Each person supervising a change shall place his or her seal (or equivalent information, including registration number and expiration date), and signature on the plan and indicate the change involved in the revision block, see Figure 3.1.

C. During Advertisement - (Addendum)

All revisions shall be made using 1/8" high numerals in a 1/4" high by 3/16" wide diamond as shown below and touching each cloud, see Figure 3.2.

Both the diamond and revision numeral shall be included in the left hand revision block. The revision number without the symbol shall be placed in the right revision block.



D. After Contract Award Change Notice

All revisions shall be made using 1/8" numerals in a 9/32" equilateral triangle as shown below:



Both the triangle and revision numeral shall be included in the left hand revision block. The revision number without the symbol shall be placed in the right revision block, see Figure 3.3.

E. Third Party Changes

An inverted triangle, as shown below, shall be used for utility, traffic, and street lighting drawings developed by jurisdictions.



Both the triangle and revision numeral shall be included in the left hand revision block. The revision number without the symbol shall be placed in the right revision block.



3.0.5 Revision Block

- A. All entries shall be keyed-in in CADD drawings (see [Figure 3.0](#), [Figure 3.1](#) and [Figure 3.2](#)).
- B. For each revision of a contract drawing):
 1. Enter revision number. See [paragraph 3.1.6](#). Increment the right hand revision block number by one and place the review symbol with the new revision number in the next available entry line in the revision block. Revision numbers shall follow in sequence from addendum numbering.
 2. Enter revision date in the format month-day-year with hyphen (-) as separator, do not use leading zeros in the day or month. (05-23-94).
 3. Provide a description of the revision, for example, ADD #4 for addendum 4 or CN-002 for Change Notice No.2, see [Figure 3.2](#).
 4. In the border sheets, where spaces are provided in the revision block, the engineer or architect responsible for the change shall electronically key-in (or have keyed-in) the revision date, his or her registration number, expiration date and the description and shall sign his or her full name in the entry spaces following the revision number.
 5. The lead architect’s or engineer’s initials shall be included in the “BY” space. The Project Manager or designee’s initials shall be placed in the “APP” space.

▽	01-14-16	100% SUBMITTAL	-----	CH	IN
▽	12-10-15	90% SUBMITTAL	-----	CH	IN
▽	09-01-15	80% SUBMITTAL	-----	CH	IN
▽	05-04-15	30% SUBMITTAL	-----	CH	IN
REV.	DATE			BY	APP.

AC=SCRRRA RVA
 TX=0.125, TW=0.10, FT=1
 WT=2, LV=1

Figure 3.0 SCRRRA Revision Cell for Design Phase



REV.	DATE		BY	APP.
③	01-14-15	REVISED PER ADDENDUM #3	CH	IN
②	12-10-15	REVISED PER ADDENDUM #2	CH	IN
①	09-01-15	REVISED PER ADDENDUM #1	CH	IN
0	05-04-15	ISSUED FOR BID	CH	IN

AC=SCRRA RVD
 TX=0.125, TW=0.10, FT=1
 WT=2, LV=1
 AC=SCRRA REV

Figure 3.1 SCRRA Revision Cell for Issued For Bid

REV.	DATE		BY	APP.
▲	01-14-15	REVISED PER CN-003	CH	IN
▲	12-10-15	REVISED PER CN-002	CH	IN
▲	09-01-15	REVISED PER CN-001	CH	IN
0	05-04-15	CONFORMED	CH	IN

AC=SCRRA RVT
 TX=0.125, TW=0.10, FT=1
 WT=2, LV=1
 AC=SCRRA REV
 TX=0.125, TW=0.10, FT=1
 WT=2, LV=1

Figure 3.2 SCRRA Revision Cell for Conformed

3.0.6 Revision Procedure

- A. An outline “cloud” shall be drawn to fully enclose each separated area of change on the sheet. The outline must not obscure information and must be distinctive from drawing content such as trees and shrubs. The outline for each revision shall replace those of a previous revision.
- B. An appropriate revision symbol with the revision number shall be placed in contact with each area of change identified by the outline “cloud” described above. The revision symbols shall remain throughout the addenda, conforming or construction change processes.
- C. Revision entries shall start above the revision 0 “ISSUED FOR BID” entry at the bottom of the revision block. Each successive entry shall be placed above the proceeding.
- D. Change notices shall be listed in the order incorporated from earliest to latest, which is not necessarily in sequence with the change notice numbering.



- E. At conforming, all clouds or bubbles shall be erased in preparation for the issue of award. Entries in the revision block and symbols within the drawing shall remain. The designation “ISSUED FOR CONSTRUCTION” shall be entered on each drawing.
- F. If the revision block should become full with revision entries, it is acceptable to delete revision entry and roll down the revision entries to make room for subsequent revisions. Delete the earliest revision entry following the Revision 0 entry but do not delete the Revision 0 entry. Refer to User [Appendix 10](#).

3.0.7 Issue and Revision Dates

The date of the initial issue or revision must be lettered by CADD and shall be as follows:

- A. Preliminary Engineering Date drawings accepted by SCRRA
- B. Standard/Directive Drawings Date drawings approved by SCRRA
- C. Bid Drawings Date drawings were completed
- D. Addenda Drawings Date the change was incorporated
- E. Conformed Drawings Date drawings were completed
- F. Change Notice Drawings Date the change was incorporated
- G. Project Record Drawings Date the revisions as-built were incorporated

3.0.8 Revision Descriptions

The content of the “description” space of the revision block shall include the change type and number as described in the following. The documents authorizing the revision already provide detail descriptions of the changes made to the drawing so supplementary description for addenda and contract changes notices is not needed.

- A. Addenda Addendum - number ADD-02
- B. Changes to Approved Systemwide Baseline Standard/Directive Drawings Change Request - number SBCN-003
- C. Change Notice/Drawings Approved CN-number CN-005
- D. Project Record Drawings Record Drawing – Field Comments with Field Changes
- E. Without Field Changes Record Drawing - No changes on this drawing



3.1 STANDARD AND DIRECTIVE DRAWINGS

Standard and directive drawings are controlled documents. They are to be maintained by SCRRA and distributed to participants in the rail design program.

Standard drawings define and describe those elements that are used repetitively. They are intended to be included in contract drawing packages with the signature and seal of the SCRRA engineer or architect. These drawings are prepared under the direction of SCRRA's engineer or architect who signs and seals them and will be responsible for the content.

Directive drawings define the general configuration of facilities for the guidance of designers and are provided for information and instruction purposes only. They are not intended as part of the contract drawings and are not required to be signed or sealed.

3.1.1 Incorporating Standard and Directive Drawings Into Contract Drawings

- A. Directive drawing electronic data may be obtained and used as the basis for project contract drawings prepared, signed and sealed by the firm preparing the drawings. In these cases, all names, dates, drawing numbers, titles and general items related to the directive drawings shall be replaced by members of the firm preparing the drawings.
- B. Electronic data for standard drawing details may be used in developing contract drawing details but may not be used to reproduce the standard drawing or modify any standard provision of a standard requirement.
- C. Copies of signed and sealed SCRRA standard drawings may be provided and only these copies be included in the project drawing packages.
- D. Standard drawings requiring project specific data, such as soil bearing value, ladder schedule data, etc. shall be processed where possible by providing the data in contract drawings referenced to the standard drawing.

3.1.2 Changes to Standard and Directive Drawings

Any programwide changes to standard drawings shall be executed by SCRRA in accordance with established revision procedures. Such changes do not retroactively apply to standard drawings once they are included in a baselined project. If systemwide changes are applicable to a baselined project, the changes must be incorporated into the project by addendum or change notice as appropriate.

The procedures for baselining systemwide standard and directive drawings for initial and revision issue are the same as for baselining project contract drawings except as follows:

- A. The addendum procedures do not apply. All revisions are processed as change requests using the triangles as described above.
- B. "REV 0", revision date and the description, "BASELINE ISSUE" is entered in the bottom line of the revision block. No other entries on the line are required.
- C. The revision and drawing approval dates entered shall be those specified in the Issue and Revision Dates paragraph.



3.2 REVISIONS TO SEALED DOCUMENTS

3.2.1 Revisions by Others

Revisions to a sealed contract drawing may be executed under the supervision of a person different than the one who sealed the initial baseline drawing.

3.2.2 Process

All modifications to sealed documents not made by the original sealer shall be accomplished through either:

- A. Reseal the drawing and indicate particular details or area that were revised with the clouds.
- B. Reseal and instead of clouding the entire drawing, indicate “revised and redrawn” in the revision box.

3.2.3 Revisions to a Standard Drawing

Revisions to a standard drawing shall always be re-sealed by the responsible engineer or architect.

3.3 Reference Drawings

- A. Drawing(s) from another contract (or an outside source) may be included within a contract package for reference purposes, if appropriate. The origin of the drawing(s) shall be clearly stated. If the drawing is not from another contract, it shall be assigned a “RE Series” drawing number.
- B. Every drawing to which reference is made in a contract package (except city/county or CALTRANS standards) must be included in the contract set. It may be a contract drawing or a reference drawing.
- C. All reference drawings must be clearly marked “For Reference Only, Not For Construction.” Reference drawings do not require professional seals, signatures nor “Submitted” and “Approved” blocks.
- D. Drawings prepared by others and incorporated in a project drawing set, which are not identified as reference drawings, shall be provided with completed engineering consultant “Submitted” and “Approved” blocks. Those lacking professional seals and signatures shall be reviewed, sealed and signed as appropriate.
- E. The “For Reference Only, Not for Construction” block should be placed in the lower right portion of the drawing.
- F. If the reference drawing is from another contract, the reference drawing block shall contain the contract number of the package to which it is being added as well as an “RD series” drawing number.
- G. For larger projects, the reference drawings may be included as a separate volume.



- H. The only changes that can be made to a reference drawing are:
 - 1. Adding “For Reference Only, Not For Construction”.
 - 2. Adding a reference drawing block, contract number and sheet number.
 - 3. Portions that are not applicable to the contract shall be crossed out and labeled in large hand lettered type with the word “OMIT”.

3.4 Installation Drawings

Installation contracts may utilize drawing data from other contracts such as site plans, platform plans, floor plans, and plan and profiles. The drawing or CADD data may be used in developing installation drawings provided the following changes are made to the CADD data:

- A. Original contract title, drawing title, contract number, sheet number and drawing number must be removed and replaced with those of the installation contract.
- B. Seal, date, logo in “Submitted” and all signatures must be removed and replaced with those of the installation contract designer.
- C. All entries in the revision block must be removed.

Once these changes are made, the drawing becomes a contract drawing in the installation contract package and is subject to all guidelines and criteria contained herein.



4.0 USER APPENDIX

USER APPENDIX



Appendix 1 – Additional Discipline Code Designators

Designator		Description	Content	Project BK / Sub-Project 201 -- File Name Examples		
Level 1	Level 2			Model	Xref / Reference	Sheet
G		General	All or any portion of subjects included in Level 2			
-	GI	General Information	Drawing Index, code summary, symbol legend, orientation maps	BK201GI001.dgn	XBK201GI01.dgn	BK201-GI-001.sht
-	GC	General Contract	Phasing, schedules, contractor staging	BK201GC001.dgn	XBK201GC01.dgn	BK201-GC-001.sht
-	GR	General Resource	Photographs, soil borings	BK201GR001.dgn	XBK201GR01.dgn	BK201-GR-001.sht
-	GJ		User Defined			
	GK		User Defined			
H		Hazardous Material	All or any portion of subjects included in Level 2	BK201H001.dgn	XBK201H001.dgn	BK201-H-001.sht
-	HJ		User Defined			
-	HK		User Defined			
V		Survey / Mapping	All or any portion of subjects included in Level 2	BK201V001.dgn	XBK201V01.dgn	BK201-V-001.sht
-	VA	Aerial				
-	VF	Field				
-	VI	Digital				
-	VR	Right of Way				
-	VU	Combined Utilities				
-	VJ		User Defined			
-	VK		User Defined			
B		Geotechnical	All or any portion of subjects included in Level 2	BK201B001.dgn	XBK201B01.dgn	BK201-B-001.sht
-	BJ		User Defined			
-	BK		User Defined			
W		Civil Works	All or any portion of subjects included in Level 2	BK201W001.dgn	XBK201W01.dgn	BK201-W-001.sht
-	WJ		User Defined			
-	WK		User Defined			
C		Civil	All or any portion of subjects included in Level 2	BK201C001.dgn	XBK201C01.dgn	BK201-C-001.sht
-	CI	Civil Improvements	Pavers, exterior tile, retaining walls and water features.			
-	CT	Civil Transportation	Waterways, wharves, docks, trams, railways, people movers			
-	CJ		User Defined			
-	CK		User Defined			
L		Landscape	All or any portion of subjects included in Level 2	BK201L001.dgn	XBK201L01.dgn	BK201-L-001.sht
-	LJ		User Defined			
-	LK		User Defined			
S		Structural	All or any portion of subjects included in Level 2	BK201S001.dgn	XBK201S01.dgn	BK201-S-001.sht
-	SS	Structural Site				
-	SB	Structural	Foundations, piers, slabs, and			



Designator		Description	Content	Project BK / Sub-Project 201 -- File Name Examples		
Level 1	Level 2			Model	Xref / Reference	Sheet
		Substructure	retaining walls			
-	SF	Structural Framing	Floors and roofs			
-	SJ		User Defined			
-	SK		User Defined			
A		Architectural	All or any portion of subjects included in Level 2	BK201A001.dgn	XBK201A01.dgn	BK201-A-001.sht
-	AS	Architectural Site				
-	AE	Architectural Elements	General Architectural			
-	AI	Architectural Interiors				
-	AF	Architectural Finishes				
-	AG	Architectural Graphics				
-	AJ		User Defined			
-	AK		User Defined			
I		Interiors	All or any portion of subjects included in Level 2	BK201I001.dgn	XBK201I01.dgn	BK201-I-001.sht
-	IJ		User Defined			
-	IK		User Defined			
	PR	Process	All or any portion of subjects included in Level 2	BK201PR001.dgn	BK201PR01.dgn	BK201-PR-001.dgn
R		Resource	All or any portion of subjects included in Level 2	BK201R001.dgn	BK201R01.dgn	BK201-R-001.dgn
	TY	Security		BK201TY001.dgn	BK201TY01.dgn	BK201-TY-001.dgn
J		Justice/ Detention	All or any portion of subjects included in Level 2	BK201J001.dgn	BK201J01.dgn	BK201-J-001.dgn
K		Food Service	All or any portion of subjects included in Level 2	BK201K001.dgn	BK201K01.dgn	BK201-K-001.dgn
O		Operations	All or any portion of subjects included in Level 2	BK201O001.dgn	BK201O01.dgn	BK201-O-001.dgn
X		Other Disciplines	All or any portion of subjects included in Level 2	BK201X001.dgn	BK201X01.dgn	BK201-X-001.dgn
Z		Contractors / Shop Drawings	All or any portion of subjects included in Level 2	BK201Z001.dgn	BK201Z01.dgn	BK201-Z-001.dgn
	3D	3D Software generated Items		BK2013D001.dgn	BK2013D01.dgn	BK201-3D-001.dgn



Appendix 2 - Scale Factor Chart (English)

SCALE FACTOR CHART -- ENGLISH																						
TEXT HEIGHT & TEXT WIDTH IN MASTER UNITS											TEXT WIDTH FACTOR OF TEXT HEIGHT=				80.0%							
											0.09375 inch		0.12500 inch		0.18750 inch		0.21875 inch		0.25000 inch		0.37500 inch	
ENGLISH SCALE	PLOT RATIO INCHES	DGN SCALE	WEIGHT = 1		WEIGHT = 1		WEIGHT = 2		WEIGHT = 0		WEIGHT = 0		WEIGHT = 0									
			TH=	TW=	TH=	TW=	TH=	TW=	TH=	TW=	TH=	TW=	TH=	TW=								
FULL SIZE	0.0833	:1	1	:1	0.0078	0.0063	0.0104	0.0083	0.0156	0.0125	0.0182	0.0146	0.0208	0.0167	0.0313	0.0250						
6"=1'-0"	0.1667	:1	2	:1	0.0156	0.0125	0.0208	0.0167	0.0313	0.0250	0.0365	0.0292	0.0417	0.0333	0.0625	0.0500						
3"=1'-0"	0.3333	:1	4	:1	0.0313	0.0250	0.0417	0.0333	0.0625	0.0500	0.0729	0.0583	0.0833	0.0667	0.1250	0.1000						
1 1/2"=1'-0"	0.6667	:1	8	:1	0.0625	0.0500	0.0833	0.0667	0.1250	0.1000	0.1458	0.1167	0.1667	0.1333	0.2500	0.2000						
1"=1'-0"	1.0000	:1	12	:1	0.0938	0.0750	0.1250	0.1000	0.1875	0.1500	0.2188	0.1750	0.2500	0.2000	0.3750	0.3000						
3/4"=1'-0"	1.3333	:1	16	:1	0.1250	0.1000	0.1667	0.1333	0.2500	0.2000	0.2917	0.2333	0.3333	0.2667	0.5000	0.4000						
1/2"=1'-0"	2.0000	:1	24	:1	0.1875	0.1500	0.2500	0.2000	0.3750	0.3000	0.4375	0.3500	0.5000	0.4000	0.7500	0.6000						
3/8"=1'-0"	2.6667	:1	32	:1	0.2500	0.2000	0.3333	0.2667	0.5000	0.4000	0.5833	0.4667	0.6667	0.5333	1.0000	0.8000						
1/4"=1'-0"	4.0000	:1	48	:1	0.1875	0.1500	0.5000	0.4000	0.7500	0.6000	0.8750	0.7000	1.0000	0.8000	1.5000	1.2000						
3/16"=1'-0"	5.3333	:1	64	:1	0.5000	0.4000	0.6667	0.5333	1.0000	0.8000	1.1667	0.9333	1.3333	1.0667	2.0000	1.6000						
1/8"=1'-0"	8.0000	:1	96	:1	0.7500	0.6000	1.0000	0.8000	1.5000	1.2000	1.7500	1.4000	2.0000	1.6000	3.0000	2.4000						
1"=10'	10.0000	:1	120	:1	0.9375	0.7500	1.2500	1.0000	1.8750	1.5000	2.1875	1.7500	2.5000	2.0000	3.7500	3.0000						
1/16"=1'-0"	16.0000	:1	192	:1	1.5000	1.2000	2.0000	1.6000	3.0000	2.4000	3.5000	2.8000	4.0000	3.2000	6.0000	4.8000						
1"=20'	20.0000	:1	240	:1	1.8750	1.5000	2.5000	2.0000	3.7500	3.0000	4.3750	3.5000	5.0000	4.0000	7.5000	6.0000						
1"=30'	30.0000	:1	360	:1	2.8125	2.2500	3.7500	3.0000	5.6250	4.5000	6.5625	5.2500	7.5000	6.0000	11.2500	9.0000						
1"=40'	40.0000	:1	480	:1	3.7500	3.0000	5.0000	4.0000	7.5000	6.0000	8.7500	7.0000	10.0000	8.0000	15.0000	12.0000						
1"=50'	50.0000	:1	600	:1	4.6875	3.7500	6.2500	5.0000	9.3750	7.5000	10.9375	8.7500	12.5000	10.0000	18.7500	15.0000						
1"=60'	60.0000	:1	720	:1	5.6250	4.5000	7.5000	6.0000	11.2500	9.0000	13.1250	10.5000	15.0000	12.0000	22.5000	18.0000						
1"=100'	100.0000	:1	1200	:1	9.3750	7.5000	12.5000	10.0000	18.7500	15.0000	21.8750	17.5000	25.0000	20.0000	37.5000	30.0000						
1"=200'	200.0000	:1	2400	:1	18.7500	15.0000	25.0000	20.0000	37.5000	30.0000	43.7500	35.0000	50.0000	40.0000	75.0000	60.0000						
1"=300'	300.0000	:1	3600	:1	28.1250	22.5000	37.5000	30.0000	56.2500	45.0000	65.6250	52.5000	75.0000	60.0000	112.5000	90.0000						
1"=500'	500.0000	:1	6000	:1	46.8750	37.5000	62.5000	50.0000	93.7500	75.0000	109.3750	87.5000	125.0000	100.0000	187.5000	150.0000						
USE FONTS 1 OR 3 ONLY									USE FONT 43 ONLY						USE FONT 45 ONLY							



Appendix 3 - Pen Table Definition (MicroStation)

MicroStation Color No.

Color		MicroStation			Shading Percent
MS	MS	Line Width	Pen Width		
No.	Weight	(inches)	(mm)		
0	2	0.010"	.25mm		
1	7	0.039"	1.00mm		
2	4	0.020"	.50mm		
3	2	0.010"	.25mm		
4	3	0.014"	.35mm		
5	0	0.004"	.10mm		
6	1	0.007"	.18mm		
7	6	0.028"	.70mm		
8	2	0.010"	.25mm	85%	
9	3	0.014"	.35mm	50%	
10	1	0.007"	.18mm		
11	1	0.007"	.18mm		
12	1	0.007"	.18mm		
13	1	0.007"	.18mm	85%	
14	0	0.004"	.10mm		
15	2	0.010"	.25mm		
16	4	0.020"	.50mm		
17	1	0.007"	.18mm		
18	3	0.014"	.35mm		
19	2	0.010"	.25mm		
20	1	0.007"	.18mm		
21	3	0.014"	.35mm	85%	
22	3	0.014"	.35mm		
23	3	0.014"	.35mm		
24	3	0.014"	.35mm		
25	2	0.010"	.25mm		
26	2	0.010"	.25mm		
27	3	0.014"	.35mm		
28	2	0.010"	.25mm		
29	2	0.010"	.25mm	85%	
30	2	0.010"	.25mm		
31	4	0.020"	.50mm		
32	6	0.028"	.70mm		
33	3	0.014"	.35mm		
34	6	0.028"	.70mm		
35	4	0.020"	.50mm		
36	3	0.014"	.35mm		
37	6	0.028"	.70mm	85%	
38	6	0.028"	.70mm		
39	6	0.028"	.70mm		



Color		MicroStation			Shading Percent
MS No.	MS Weight	Line	Pen	Width	
		Width	Width		
		(inches)	(mm)		
40	1	0.007"	.18mm		
41	4	0.020"	.50mm		
42	4	0.020"	.50mm		
43	6	0.028"	.70mm		
44	4	0.020"	.50mm		
45	4	0.020"	.50mm	85%	
46	4	0.020"	.50mm		
47	7	0.039"	1.00mm		
48	7	0.039"	1.00mm		
49	6	0.028"	.70mm		
50	0	0.004"	.10mm		
51	7	0.039"	1.00mm		
52	6	0.028"	.70mm		
53	0	0.004"	.10mm	85%	
54	0	0.004"	.10mm		
55	0	0.004"	.10mm		
56	7	0.039"	1.00mm	15%	
57	7	0.039"	1.00mm		
58	7	0.039"	1.00mm		
59	0	0.004"	.10mm		
60	7	0.039"	1.00mm		
61	7	0.039"	1.00mm	85%	
62	7	0.039"	1.00mm		
63	6	0.028"	.70mm	35%	
64	0	0.004"	.10mm		
65	0	0.004"	.10mm		
66	3	0.014"	.35mm	50%	
67	6	0.028"	.70mm	35%	
68	0	0.004"	.10mm		
69	3	0.014"	.35mm	85%	
70	3	0.014"	.35mm	50%	
71	3	0.014"	.35mm	50%	
72	2	0.010"	.25mm		
73	6	0.028"	.70mm	35%	
74	6	0.028"	.70mm	35%	
75	3	0.014"	.35mm	50%	
76	6	0.028"	.70mm	35%	
77	6	0.028"	.70mm	85%	
78	6	0.028"	.70mm	35%	
79	5	0.024"	.60mm		
80	6	0.028"	.70mm	35%	
81	3	0.014"	.35mm	50%	



Color		MicroStation			Shading Percent
MS No.	MS Weight	Line	Pen	Width (mm)	
		Width	Width		
		(inches)			
82	1	0.007"	.18mm		
83	5	0.024"	.60mm		
84	3	0.014"	.35mm	50%	
85	1	0.007"	.18mm	70%	
86	1	0.007"	.18mm		
87	1	0.007"	.18mm		
88	3	0.014"	.35mm		
89	5	0.024"	.60mm		
90	5	0.024"	.60mm		
91	1	0.007"	.18mm	30%	
92	5	0.024"	.60mm		
93	5	0.024"	.60mm	85%	
94	5	0.024"	.60mm		
95	2	0.010"	.25mm		
96	3	0.014"	.35mm	50%	
97	1	0.007"	.18mm		
98	3	0.014"	.35mm		
99	2	0.010"	.25mm	30%	
100	1	0.007"	.18mm		
101	3	0.014"	.35mm	70%	
102	3	0.014"	.35mm		
103	3	0.014"	.35mm		
104	4	0.020"	.50mm		
105	2	0.010"	.25mm		
106	2	0.010"	.25mm		
107	3	0.014"	.35mm	30%	
108	2	0.010"	.25mm		
109	2	0.010"	.25mm	70%	
110	2	0.010"	.25mm		
111	4	0.020"	.50mm		
112	5	0.024"	.60mm		
113	3	0.014"	.35mm		
114	6	0.028"	.70mm		
115	4	0.020"	.50mm	30%	
116	3	0.014"	.35mm		
117	6	0.028"	.70mm	70%	
118	6	0.028"	.70mm		
119	6	0.028"	.70mm		
120	6	0.028"	.70mm	30%	
121	4	0.020"	.50mm		
122	4	0.020"	.50mm		
123	6	0.028"	.70mm	30%	



Color		MicroStation			Shading Percent
MS No.	MS Weight	Line	Pen	Width (mm)	
		Width	Width		
		(inches)	(mm)		
124	4	0.020"	.50mm		
125	4	0.020"	.50mm	70%	
126	4	0.020"	.50mm		
127	7	0.039"	1.00mm		
128	2	0.010"	.25mm		
129	6	0.028"	.70mm		
130	0	0.004"	.10mm		
131	7	0.039"	1.00mm	30%	
132	6	0.028"	.70mm		
133	0	0.004"	.10mm	70%	
134	0	0.004"	.10mm		
135	0	0.004"	.10mm		
136	6	0.028"	.70mm		
137	7	0.039"	1.00mm		
138	7	0.039"	1.00mm		
139	0	0.004"	.10mm	30%	
140	7	0.039"	1.00mm		
141	7	0.039"	1.00mm	70%	
142	7	0.039"	1.00mm		
143	6	0.028"	.70mm	35%	
144	3	0.014"	.35mm		
145	0	0.004"	.10mm		
146	3	0.014"	.35mm	50%	
147	6	0.028"	.70mm	30%	
148	0	0.004"	.10mm		
149	3	0.014"	.35mm	70%	
150	3	0.014"	.35mm	50%	
151	3	0.014"	.35mm	50%	
152	7	0.039"	1.00mm		
152	6	0.028"	.70mm	35%	
154	6	0.028"	.70mm	35%	
155	3	0.014"	.35mm	30%	
156	6	0.028"	.70mm	35%	
157	6	0.028"	.70mm	70%	
158	6	0.028"	.70mm	35%	
159	5	0.024"	.60mm		
160	4	0.020"	.50mm		
161	3	0.014"	.35mm	50%	
162	1	0.007"	.18mm		
163	5	0.024"	.60mm	30%	
164	3	0.014"	.35mm	50%	
165	1	0.007"	.18mm	50%	



Color		MicroStation			Shading Percent
MS No.	MS Weight	Line	Pen		
		Width	Width		
		(inches)	(mm)		
166	1	0.007"	.18mm		
167	1	0.007"	.18mm		
168	4	0.020"	.50mm	50%	
169	5	0.024"	.60mm		
170	5	0.024"	.60mm		
171	1	0.007"	.18mm	15%	
172	5	0.024"	.60mm		
173	5	0.024"	.60mm	70%	
174	5	0.024"	.60mm		
175	2	0.010"	.25mm		
176	6	0.028"	.70mm		
177	1	0.007"	.18mm		
178	3	0.014"	.35mm		
179	2	0.010"	.25mm	15%	
180	1	0.007"	.18mm		
181	3	0.014"	.35mm	50%	
182	3	0.014"	.35mm		
183	3	0.014"	.35mm		
184	0	0.004"	.10mm		
185	2	0.010"	.25mm		
186	2	0.010"	.25mm		
187	3	0.014"	.35mm	15%	
188	2	0.010"	.25mm		
189	2	0.010"	.25mm	50%	
190	2	0.010"	.25mm		
191	4	0.020"	.50mm		
192	7	0.039"	1.00mm		
193	3	0.014"	.35mm		
194	6	0.028"	.70mm		
195	4	0.020"	.50mm	15%	
196	3	0.014"	.35mm		
197	6	0.028"	.70mm	50%	
198	6	0.028"	.70mm		
199	6	0.028"	.70mm		
200	3	0.014"	.35mm	70%	
201	4	0.020"	.50mm		
202	4	0.020"	.50mm		
203	6	0.028"	.70mm	15%	
204	4	0.020"	.50mm		
205	4	0.020"	.50mm	50%	
206	4	0.020"	.50mm		
207	7	0.039"	1.00mm		



Color		MicroStation			Shading Percent
MS	MS	Line	Pen		
		Width (inches)	Width (mm)		
No.	Weight				
208	0	0.004"	.10mm		
209	6	0.028"	.70mm		
210	0	0.004"	.10mm		
211	7	0.039"	1.00mm	15%	
212	6	0.028"	.70mm		
213	0	0.004"	.10mm	50%	
214	0	0.004"	.10mm		
215	0	0.004"	.10mm		
216	6	0.028"	.70mm	35%	
217	7	0.039"	1.00mm		
218	7	0.039"	1.00mm		
219	0	0.004"	.10mm	15%	
220	7	0.039"	1.00mm		
221	7	0.039"	1.00mm	50%	
222	7	0.039"	1.00mm		
223	6	0.028"	.70mm	35%	
224	6	0.028"	.70mm	35%	
225	0	0.004"	.10mm		
226	3	0.014"	.35mm	50%	
227	6	0.028"	.70mm	30%	
228	0	0.004"	.10mm		
229	3	0.014"	.35mm	50%	
230	3	0.014"	.35mm	50%	
231	3	0.014"	.35mm	50%	
232	3	0.014"	.35mm	50%	
233	6	0.028"	.70mm	35%	
234	6	0.028"	.70mm	35%	
235	3	0.014"	.35mm	15%	
236	6	0.028"	.70mm	35%	
237	6	0.028"	.70mm	50%	
238	6	0.028"	.70mm	35%	
239	5	0.024"	.60mm		
240	3	0.014"	.35mm	50%	
241	3	0.014"	.35mm	50%	
242	1	0.007"	.18mm		
243	5	0.024"	.60mm	15%	
244	3	0.014"	.35mm	50%	
245	1	0.007"	.18mm		
246	2	0.010"	.25mm		
247	3	0.014"	.35mm		
248	5	0.024"	.60mm		



Color		MicroStation			Shading Percent
MS	MS	Line	Pen		
		Width (inches)	Width (mm)		
No.	Weight				
249	5	0.024"	.60mm		
250	5	0.024"	.60mm		
251	5	0.024"	.60mm		
252	5	0.024"	.60mm		
253	5	0.024"	.60mm	50%	
254	5	0.024"	.60mm		

Appendix 4 - Line Weights to Pen Widths

Width - Inches	0.004"	0.007"	0.010"	0.014"	0.020"	0.024"	0.028"	0.039"
Width - mm	0.10 mm	0.18 mm	0.25 mm	0.35 mm	0.50 mm	0.60 mm	0.70 mm	1.00 mm
LW=	0	1	2	3	4	5	6	7



Appendix 5 – SCRRRA Discipline Levels

5.1 Core Levels (All Disciplines)

Lv	Co	Lc	Wt	Description
1	0	0	V	Title block information
2	*	*	*	reserved
3	*	*	*	reserved
4	3	0	1	N. arrow/scales/key maps
5	0	0	3	Section/detail callouts
6	3	0	6	Match lines
7	0	0	1	Registration Stamps/Notes
8				
9				
10				
11				
12				
13				
14				
15				
16				
17				
18				
19				
20	*	*	*	reserved
21	*	*	*	reserved
22				
23				
24				
25				
26				
27				
28				
29				
30				
31	*	*	*	reserved
32	*	*	*	reserved
33				
34				
35				
36				
37				
38				
39				
40				
41				
42				
43				
44				
45	0	0	V	Tables, Schedules & text
46				
47				
48				
49				
50	0	0	V	Dimensions & leader lines
51	0	0	V	Drawing notes
52				
53				
54				
55	V	0	0	Raster-fill patterns
56	1	0	0	Area fill patterns
57	5	V	V	Linear patterns



5.1 Core Levels (All Disciplines)

Lv	Co	Lc	Wt	Description
58	V	0	0	Color fill patterns
59	*	*	*	reserved
60	2	*	3	Rev. Sym/clouds (*Treeline)
				Adjust LC Scale as required
				Non-plotting levels
61	4	1	0	Ref. file clipping limits
62	*	*	*	reserved
63	5	0	0	Constr. lines, Guides
	V			Varies for color
		V		Varies for line codes
			V	Varies for weight

5.2 Architectural Plan Levels

Lv	Co	Lc	Wt	Description
1	0	0	V	Title block information
2	*	*	*	reserved
3	*	*	*	reserved
4	3	0	1	N. arrow/scales/key maps
5	0	0	3	Section/detail callouts
6	3	0	6	Match lines
7	0	0	1	Registration Stamps
8	3	0	0	Room perimeter
9	4	0	2	Exterior perimeter shape
10	2	2	1	Wall insulation
11	5	4	0	Curtain wall center lines
12	6	0	1	Curtain wall mullions
13	3	4	0	Column grid - centerline
14	3	0	1	Windows
15	5	3	1	Handrails
16	7	0	2	Slabs
17	1	0	0	Stair nosing/risers
18	3	0	1	Doors & door swings
19	4	6	0	Plumbing fixtures
20	*	*	*	reserved
21	*	*	*	reserved
22	11	5	1	Acoustic materials
23	12	0	1	Paving, tile patterns
24				
25	14	0	1	Parking stalls
26	6	0	1	Walks, roads, curbs
27	5	6	2	Site limits, R.O.W. limits
28	4	2	0	Existing buildings
29	3	0	1	Landscaping
30				
31	*	*	*	reserved
32	*	*	*	reserved
33	2	0	1	Interior furnishings
34	1	0	1	Exterior furnishings
35	3	0	1	Finish floor lines
36	5	0	1	Exterior walls
37	1	0	1	Window openings
38	2	0	1	Stairs
39	4	3	1	Beams
40	6	5	1	Slabs
41	7	0	1	Wall fire ratings
42	11	3	1	Ceiling pattern -- grid
43	13	0	1	Shafts/roof penetrations
44				
45	0	0	V	Tables, Schedules & text
46				



5.2 Architectural Plan Levels

Lv	Co	Lc	Wt	Description
47	2	0	0	Smoke & heat detectors
48	1	3	0	Communications/speakers
49				
50	0	0	V	Dimensions & leader lines
51	0	0	V	Drawing notes
52	6	2	1	Sprinklers
53	7	6	1	Equipment
54				
55	V	0	0	Raster-fill patterns
56	1	0	0	Area fill patterns
57	6	V	V	Linear patterns
58	V	0	0	Color fill patterns
59	*	*	*	reserved
60	2	*	3	Rev. Sym/clouds (*Treeline)
				Non-plotting levels
61	4	1	0	Ref. file clipping limits
62	*	*	*	reserved
63	5	0	0	Constr. lines, Guides
	V			Varies for color
		V		Varies for line codes
			V	Varies for weight

5.3 Track Levels

Lv	Co	Lc	Wt	Description
1	0	0	V	Title block information
2	*	*	*	reserved
3	*	*	*	reserved
4	3	0	1	N. arrow/scales/key maps
5	0	0	3	Section/detail callouts
6	3	0	6	Match lines
7	0	0	1	Registration Stamps
8				
9				
10				
11				
12				
13	2	0	1	Track Mainline SCRRRA
14	3	0	8	Track Stage One (#1)
15	4	0	8	Track Stage Two (#2)
16	5	0	8	Track Stage Three (#3)
17	6	0	1	Track Stage Four (#4)
18	7	0	1	Track Stage Five (#5)
19				
20	*	*	*	Reserved
21	*	*	*	Reserved
22				
23				
24				
25	5	0	V	Trk Rail Profile-Proposed
26	4	0	V	Trk Rail Profile-Existing
27				
28				
29	6	0	2	Track Rail Switch
30				
31	*	*	*	reserved
32	*	*	*	reserved
33				
34	1	0	V	Major Ticks/STA (#1)
35	2	0	V	Major Ticks/STA (#2)
36	3	0	V	Major Ticks/STA (#3)
37	4	0	V	Major Ticks/STA (#4)



5.3 Track Levels

Lv	Co	Lc	Wt	Description
38	5	0	V	Major Ticks/STA (#5)
39				
40				
41				
42				
43				
44	1			Cardinal Stationing (#1)
45	2			Cardinal Stationing (#2)
46	3			Cardinal Stationing (#3)
47	4			Cardinal Stationing (#4)
48	5			Cardinal Stationing (#5)
49				
50	0	0	V	Dimensions & leader lines
51	0	0	V	Drawing notes
52				
53				
54				
55				
56	1	0	0	Area fill patterns
57	6	V	V	Linear patterns
58	V	0	0	Color fill patterns
59	*	*	*	reserved
60	2	*	3	Rev. Sym/clouds (*Treeline)
				Non-plotting levels
61	4	1	0	Ref. file clipping limits
62	*	*	*	reserved
63	5	0	0	Constr. lines, Guides
	V			Varies for color
		V		Varies for line codes
			V	Varies for weight

5.4 Track Communication Levels

Lv	Co	Lc	Wt	Description
1	0	0	V	Title block information
2	*	*	*	reserved
3	*	*	*	reserved
4	3	0	1	N. arrow/scales/key maps
5	0	0	3	Section/detail callouts
6	3	0	6	Match lines
7	0	0	1	Registration Stamps
8				
9				
10				
11	V	V	V	Microwave System & Communication Nodes
12	V	V	V	VHF Radio System
13	V	V	V	EOT/HOT & DP Repeater Locations
14	V	V	V	Data Radio System for Signal Conveyance
15	V	V	V	Security & Surveillance System
16	V	V	V	Primary Power & Cable
17				
18				
19				
20	*	*	*	reserved
21	*	*	*	reserved
22				
23				
24				



5.4 Track Communication Levels

Lv	Co	Lc	Wt	Description
25				
26				
27				
28				
29				
30				
31	*	*	*	<i>reserved</i>
32	*	*	*	<i>reserved</i>
33				
34				
35				
36				
37				
38				
39				
40				
41				
42				
43				
44				
45				
46				
47				
48				
49				
50	0	0	V	Dimensions & leader lines
51	0	0	V	Drawing notes
52				
53				
54				
55				
56	1	0	0	Area fill patterns
57	6	V	V	Linear patterns
58	V	0	0	Color fill patterns
59	*	*	*	<i>reserved</i>
60	2	*	3	Rev. Sym/clouds (*Treeline)
				<i>Non-plotting levels</i>
61	4	1	0	Ref. file clipping limits
62	*	*	*	<i>reserved</i>
63	5	0	0	Constr. lines, Guides
	V			Varies for color
		V		Varies for line codes
			V	Varies for weight

5.5 Track Signal Levels

Lv	Co	Lc	Wt	Description
1	0	0	V	Title block information
2	*	*	*	<i>reserved</i>
3	*	*	*	<i>reserved</i>
4	3	0	1	N. arrow/scales/key maps
5	0	0	3	Section/detail callouts
6	3	0	6	Match lines
7	0	0	1	Registration Stamps
8				
9				
10				
11				
12				
13				
14				
15				



5.5 Track Signal Levels

Lv	Co	Lc	Wt	Description
16				
17				
18				
19				
20	*	*	*	<i>reserved</i>
21	*	*	*	<i>reserved</i>
22	V	V	V	Insulated Joint Location
23	V	V	V	Signal Location
24	V	V	V	Inter. Wayside Location
25	V	V	V	Interlocking Location
26	V	V	V	Overpasses & Bridges
27	V	V	V	Equip. Cabinet Location
28	V	V	V	Power Drop Location
29	V	V	V	Ladder Location
30				
31	*	*	*	<i>reserved</i>
32	*	*	*	<i>reserved</i>
33	V	V	V	Hot Box Detector Location
34	V	V	V	Dragging Equip. Location
35	V	V	V	HWY Grade Crossing Location
36	V	V	V	Huts Cabinet Location
37				
38				
39				
40				
41				
42				
43				
44				
45				
46				
47				
48				
49				
50	0	0	V	Dimensions & leader lines
51	0	0	V	Drawing notes
52				
53				
54				
55	6	2	1	Track Profile-Exist. Ground
56	1	0	0	Area fill patterns
57	6	V	V	Linear patterns
58	V	0	0	Color fill patterns
59	*	*	*	<i>reserved</i>
60	2	*	3	Rev. Sym/clouds (*Treeline) <i>Non-plotting levels</i>
61	4	1	0	Ref. file clipping limits
62	*	*	*	<i>reserved</i>
63	5	0	0	Constr. lines, Guides
	V			Varies for color
		V		Varies for line codes
			V	Varies for weight

5.6 Civil Roadway Levels

Lv	Co	Lc	Wt	Description
1	0	0	V	Title block information
2	*	*	*	<i>reserved</i>
3	*	*	*	<i>reserved</i>
4	3	0	1	N. arrow/scales/key maps



5.6 Civil Roadway Levels

Lv	Co	Lc	Wt	Description
5	0	0	3	Section/detail callouts
6	3	0	6	Match lines
7	0	0	1	Registration Stamps
8				
9				
10				
11				
12				
13				
14				
15				
16				
17				
18				
19				
20	*	*	*	<i>reserved</i>
21	*	*	*	<i>reserved</i>
22				
23				
24				
25				
26				
27				
28				
29				
30				
31	*	*	*	<i>reserved</i>
32	*	*	*	<i>reserved</i>
33				
34	V	0	V	Curbs / Sidewalks
35	3	0	1	Curb Ramps
36				
37				
38				
39				
40				
41				
42				
43				
44				
45	0	0	V	Tables, Schedules & text
46				
47				
48				
49				
50	0	0	V	Dimensions & leader lines
51	0	0	V	Drawing notes
52				
53				
54	4	V	V	Pavement Markings
55	6	0	V	RR Pavement Markings
56	1	0	0	Area fill patterns
57	6	V	V	Linear patterns
58	V	0	0	Color fill patterns
59	*	*	*	<i>reserved</i>
60	2	*	3	Rev. Sym/clouds (*Treeline) <i>Non-plotting levels</i>
61	4	1	0	Ref. file clipping limits
62	*	*	*	<i>reserved</i>
63	5	0	0	Constr. lines, Guides
	V			Varies for color
		V		Varies for line codes



5.6 Civil Roadway Levels

Lv	Co	Lc	Wt	Description
			V	Varies for weight

5.7 Civil Levels

Lv	Co	Lc	Wt	Description
1	0	0	V	Title block information
2	*	*	*	<i>reserved</i>
3	*	*	*	<i>reserved</i>
4	3	0	1	N. arrow/scales/key maps
5	0	0	3	Section/detail callouts
6	3	*0	6	Match lines (*matchline)
7	0	0	1	Registration Stamps
8	5	0	2	Sanitary Sewer
9	5	0	1	Sanitary Sewer / Text
10				
11				
12				
13	0	0	0	Symbols / Text - Plans
14	12	0	V	Bearings / Stationing - Text
15	12	0	0	Symbols / Text - Profiles
16	4	0	1	Grid Tics
17	0	0	1	Grid Text
18	12	0	0	Centerline of Street
19	0	0	1	Edge of Pavement
20	*	*	*	<i>reserved</i>
21	*	*	*	<i>reserved</i>
22	5	0	V	Buildings Plan & Profiles
23	5	0	V	Buildings Text
24	6	0	V	Bridges - Plan & Profiles
25	4	0	1	Bridges Text
26	2	0	1	Fences, Retaining Walls
27	4	0	3	Major Contours & Text
28	2	2	1	Minor Contours
29	0	0	V	Ditch Centerline
30	0	0	1	Ditch Toe / Top Slopes
31	0	*0	2	Retaining Walls (*Fence)
32	0	0	1	Retaining Walls - Text
33	2	0	1	Spot Elevations
34	7	0	1	Curbs, Sidewalks, Driveway
35	4	0	2	Street Names - Text
36	1	0	1	Utilities & Misc. Text
37	12	0	1	Lt. Offset from C-L Profile
38	12	0	1	Rt. Offset from C-L Profile
39	3	0	1	Centerline Profile
40	7	5	2	Catch Basin/Grate/MH
41	5	7	2	Pipe Walls
42	10	4	1	Channel Walls
43	1	0	2	Storm Drain
44	1	0	1	Storm Drain - Text
45	0	0	2	Tables, Schedules & text
46	3	0	2	Structures Above Grade
47	11	3	1	Structures Below Grade
48				
49	7	0	V	Storm Drain - By Others
50	0	0	V	Dimensions & leader lines
51	0	0	V	Drawing notes
52	6	0	1	Bore Holes & Text
53	1	0	1	Bench Marks & Text
54	6	0	1	Marking / Striping
55	4	0	0	Raster Fill Patterns
56	1	0	0	Area fill patterns



5.7 Civil Levels

Lv	Co	Lc	Wt	Description
57	6	V	V	Linear patterns
58	V	0	0	Color fill patterns
59	*	*	*	<i>reserved</i>
60	2	*	3	Rev. Sym/clouds (*Treeline)
61	4	1	0	Ref. file clipping limits
62	*	*	*	<i>reserved</i>
63	5	0	0	Constr. lines, Guides
	V			Varies for color
		V		Varies for line codes
			V	Varies for weight

5.8 Electrical Levels

Lv	Co	Lc	Wt	Description
1	0	0	V	Title block information
2	*	*	*	<i>reserved</i>
3	*	*	*	<i>reserved</i>
4	3	0	1	N. arrow/scales/key maps
5	0	0	3	Section/detail callouts
6	3	0	6	Match lines
7	0	0	1	Registration Stamps
8				
9				
10	1	0	1	Lighting - Standard
11	2	0	1	Lighting - Special
12	3	0	1	Lighting - Emergency
13	4	0	1	Lighting - Exit
14	5	0	1	Lighting - MTD ceiling
15	6	4	1	Column grid - centerline
16	7	0	1	Lighting - MTD wall
17	11	0	1	Lighting - MTD floor
18	12	0	1	Wall outlets
19	13	0	1	Lighting - Roof
20	*	*	*	<i>reserved</i>
21	*	*	*	<i>reserved</i>
22	4	0	1	Lighting - Site
23	5	0	1	Lighting switches
24	6	0	1	Lighting circuits
25	2	0	1	Luminaire ID & text
26	3	0	1	Door #'s / KOP #'s
27	4	0	1	Room name
28				
29				
30				
31	*	*	*	<i>reserved</i>
32	*	*	*	<i>reserved</i>
33				
34				
35	2	0	1	Ref. notes - Electrical
36	3	0	1	Ref. notes - HVAC
37	5	0	1	Ref. notes - Structural
38	0	0	1	Ref. notes - Architectural
39				
40				
41				
42				
43				
44				
45	0	0	V	Tables, Schedules & text
46				
47				



5.8 Electrical Levels

Lv	Co	Lc	Wt	Description
48				
49				
50	0	0	V	Dimensions & leader lines
51	0	0	V	Drawing notes
52				
53				
54				
55	V	0	0	Raster-fill patterns
56	1	0	0	Area fill patterns
57	6	V	V	Linear patterns
58	V	0	0	Color fill patterns
59	*	*	*	<i>reserved</i>
60	2	*	3	Rev. Sym/clouds (*Treeline)
				<i>Non-plotting levels</i>
61	4	1	0	Ref. file clipping limits
62	*	*	*	<i>reserved</i>
63	5	0	0	Constr. lines, Guides
	V			Varies for color
		V		Varies for line codes
			V	Varies for weight

5.9 Structural Levels

Lv	Co	Lc	Wt	Description
1	0	0	V	Title block information
2	*	*	*	<i>reserved</i>
3	*	*	*	<i>reserved</i>
4	3	0	1	N. arrow/scales/key maps
5	0	0	3	Section/detail callouts
6	3	0	6	Match lines
7	0	0	1	Registration Stamps
8				
9				
10	0	0	1	Demolition & text
11	V	0	V	Rails / Ties / Ballast
12	0	0	2	Building outline
13	1	5	1	Property line
14	2	2	0	Phantom structure line
15	0	0	0	Stairs, railings, handrails
16	7	2	2	Beams/Girders (St & Con)
17	5	0	1	Columns, all materials
18	4	0	2	Piles
19	3	0	1	Stub Col's & stub walls
20	*	*	*	<i>reserved</i>
21	*	*	*	<i>reserved</i>
22				
23				
24				
25				
26				
27				
28				
29				
30				
31	*	*	*	<i>reserved</i>
32	*	*	*	<i>reserved</i>
33				
34				
35				
36	3	0	4	Concrete fdn's & footings
37	3	0	2	Concrete rebar, ties, etc.
38				



5.9 Structural Levels

Lv	Co	Lc	Wt	Description
39				
40				
41				
42				
43				
44				
45				
46				
47				
48				
49				
50	0	0	V	Dimensions & leader lines
51	0	0	V	Drawing notes
52				
53				
54				
55	V	0	0	Raster-fill patterns
56	1	0	0	Area fill patterns
57	6	V	V	Linear patterns
58	V	0	0	Color fill patterns
59	*	*	*	<i>reserved</i>
60	2	*	3	Rev. Sym/clouds (*Treeline) <i>Non-plotting levels</i>
61	4	1	0	Ref. file clipping limits
62	*	*	*	<i>reserved</i>
63	5	0	0	Constr. lines, Guides
	V			Varies for color
		V		Varies for line codes
			V	Varies for weight

5.10 Right of Way Levels

Lv	Co	Lc	Wt	Description
1	0	0	V	Title block information
2	*	*	*	<i>reserved</i>
3	*	*	*	<i>reserved</i>
4	3	0	1	N. arrow/scales/key maps
5	0	0	3	Section/detail callouts
6	3	0	6	Match lines
7	0	0	1	Registration Stamps
8				
9				
10				
11				
12				
13	3	0	1	Monument
14	0	0	V	Monument Text
15	3	0	1	Parcel Graphics
16				
17	5	6	5	Right-of-Way Line (SCRRA)
18	4	0	1	Right-of-Way Text (SCRRA)
19				
20	*	*	*	<i>reserved</i>
21	*	*	*	<i>reserved</i>
22				
23	7	0	1	Property Lines
24	7	0	1	Property Lines Text
25				
26	2	5	2	Easement Lines
27	2	0	1	Easement Lines Text
28				
29	6	4	1	Street Center Lines



5.10 Right of Way Levels

Lv	Co	Lc	Wt	Description
30	6	0	2	Street Names
31	*	*	*	reserved
32	*	*	*	reserved
33	7	1	2	City Limits / Boundaries
34	7	0	1	City Names
35				
36				
37				
38				
39				
40				
41				
42				
43				
44				
45	0	0	V	Tables, Schedules & Text
46				
47				
48	V	0	V	Right of Entry Const.
49				
50	0	0	V	Dimensions & leader lines
51	0	0	V	Drawing notes
52				
53				
54	2	0	1	Utility Easement
55	V	0	0	Raster-fill patterns
56	1	0	0	Area fill patterns
57	6	V	V	Linear patterns
58	V	0	0	Color fill patterns
59	*	*	*	reserved
60	2	*	3	Rev. Sym/clouds (*Treeline)
				Non-plotting levels
61	4	1	0	Ref. file clipping limits
62	*	*	*	reserved
63	5	0	0	Constr. lines, Guides
	V			Varies for color
		V		Varies for line codes
			V	Varies for weight

5.11 Utility Levels

Lv	Co	Lc	Wt	Description
1	0	0	V	Title block information
2	*	*	*	<i>reserved</i>
3	*	*	*	<i>reserved</i>
4	3	0	1	N. arrow/scales/key maps
5	0	0	3	Section/detail callouts
6	3	0	6	Match lines
7	1	0	*1	Text - CATV - Duct Ovhd
8	1	0	*1	Text - Tele. / Fiber Optic
9	2	0	*1	Text - Water
10	6	0	*1	Text - Storm Drain
11	0	0	*1	Text - Oil / Petroleum
12	1	0	*1	Text - CATV Underground
13	12	0	*1	Text - Fiber Optic Cable
14	5	0	*1	Text - Power/Elec. - U/G
15	5	0	*1	Text - Elec. Power Overhead
16	13	0	*1	Text - Sanitary Sewer
17	3	0	*1	Text - Natural Gas
18	1	0	*1	Text - Joint Elec/Tele Ovhd
19	2	0	*1	Text - Industrial Waste
20	7	0	*1	Text - Jet Fuel



5.11 Utility Levels

Lv	Co	Lc	Wt	Description
21	1	0	*1	Text - Telephone Overhead
22	1	0	*1	Text - Joint Elec/Tele - U/G
23				
24	7	**	*2	Jet Fuel
25	12	**	*2	Fiber Optic Cable
26	1	**	*2	CATV - Duct Overhead
27	0	**	*2	Oil / Petroleum
28	1	**	*2	Tele. / Fiber Optic
29	2	**	*2	Water
30	6	**	*2	Storm Drain
31	1	**	*2	Telephone Overhead
32	1	**	*2	CATV Underground
33	1	**	*2	Joint Elec. -- Tele. UG
34	7	**	*2	Power / Electrical
35	5	**	*2	Electrical Power Overhead
36	1	**	*2	Sanitary Sewer
37	3	**	*2	Gas
38	1	**	*2	Joint Elect_Tele Overhead
39	5	**	*2	Industrial Waste
40	6	0	0	Track Signal Conduit
41	7	0	0	Demolition - Water
42	4	0	1	Demolition - Gas
43	1	0	8	Demolition - Sanitary Sewer
44	5	0	8	Demolition - Storm Drain
45	0	0	V	Tables, Schedules & text
46	3	0	0	Demolition - Oil / Petroleum
47	4	0	0	Demolition - Telephone
48	52	0	2	Unwanted Utilities (All)
49	0	0	8	Under Drain
50	0	0	V	Dimensions & leader lines
51	0	0	V	Drawing notes
52	6	0	0	Text --- Pressure Drain
53	6	0	0	Text --- Under Drain
54	6	0	0	Text --- Track Signal Conduit
55	V	0	0	Raster-fill patterns
56	1	0	0	Area fill patterns
57	6	V	V	Linear patterns
58	V	0	0	Color fill patterns
59	*	*	*	<i>reserved</i>
60	2	*	3	Rev. Sym/clouds (*Treeline)
				<i>Non-plotting levels</i>
61	4	1	0	Ref. file clipping limits
62	*	*	*	<i>reserved</i>
63	5	0	0	Constr. lines, Guides
	V			Varies for color
		V		Varies for line codes
			V	Varies for weight
			*1	Existing Text WT=0
				Proposed Text WT=1
				Font = 1 --- TH = 1.5
			*2	Existing Line WT=0
				Proposed Line WT=3



5.12 Details – All Disciplines

Lv	Co	Lc	Wt	Description
1	0	0	V	Title block information
2	*	*	*	<i>reserved</i>
3	*	*	*	<i>reserved</i>
4	3	0	1	N. arrow/scales/key maps
5	0	0	3	Section/detail callouts
6	3	0	6	Match lines
7	0	0	1	Registration Stamps
8				
9				
10	5	V	V	Linework -- Existing
11	4	V	V	Linework -- Proposed
12				
13				
14				
15				
16				
17				
18				
19				
20	*	*	*	<i>reserved</i>
21	*	*	*	<i>reserved</i>
22				
23				
24				
25				
26				
27				
28				
29				
30				
31	*	*	*	<i>reserved</i>
32	*	*	*	<i>reserved</i>
33				
34				
35				
36				
37				
38				
39				
40				
41				
42				
43				
44				
45	0	0	V	Tables, Schedules & text
46				
47				
48				
49				
50	0	0	V	Dimensions & leader lines
51	0	0	V	Drawing notes
52				
53				
54				
55	V	0	0	Raster-fill patterns
56	1	0	0	Area fill patterns
57	6	V	V	Linear patterns
58	V	0	0	Color fill patterns
59	*	*	*	<i>reserved</i>
60	2	*	3	Rev. Sym/clouds (*Treeline)
				<i>Non-plotting levels</i>



5.12 Details – All Disciplines

Lv	Co	Lc	Wt	Description
61	4	1	0	Ref. file clipping limits
62	*	*	*	<i>reserved</i>
63	5	0	0	Constr. lines, Guides
	V			Varies for color
		V		Varies for line codes
			V	Varies for weight



Appendix 6 - National CADD Standard Level Names

DISCIPLINE GROUP	LEVEL NAME	MicroStation COLOR	WEIGHT (INCHES)	LINE TYPE	DESCRIPTION
	G-ANNO-CNTR	5	0.004"	CENTER2	Centerlines (For Layout)
	G-ANNO-DIMS-XXXX G-ANNO-DIMS (ADT)	10	0.007"	CONTINUOUS	Dimensions Example: G-ANNO-DIMS-0096 for 1/8"
	G-ANNO-MATC	4	0.014"	DIVIDE2	Match Lines
	G-ANNO-NOTE	0	0.010"	CONTINUOUS	Notes, Call-Outs And Keynotes
	G-ANNO-NPLT	3	0.010"	CONTINUOUS	Non Plotting Level
	G-ANNO-RDME	0	0.010"	CONTINUOUS	Readme / Notes To Drafter (No Plotting)
	G-ANNO-REVC-R#	10	0.007"	CONTINUOUS	Revision Clouds (replace # with Rev number)
	G-ANNO-REVS-R#	10	0.007"	CONTINUOUS	Revision Targets / Triangles (Replace # with Rev number)
	G-ANNO-SYMB	0	0.010"	CONTINUOUS	Graphic Symbols
	G-ANNO-TITL	0	0.010"	CONTINUOUS	Drawing Or Detail Titles
	G-ANNO-TTLB	0	0.010"	CENTER2	Border And Title Block
	G-ANNO-TTLB-DATE	0	0.010"	CONTINUOUS	Date stamp
	G-ANNO-TTLB-GRID	14	0.004"	DASHED2	Detail Module Grid Lines
	G-ANNO-TTLB-KPLN	10	0.007"	CONTINUOUS	Key plans
	G-ANNO-TTLB-NFCR	4	0.014"	CONTINUOUS	Not For Construction text
	G-ANNO-TTLB-NOSH	0	0.010"	CONTINUOUS	Sheet 1 Of _____
	G-ANNO-TTLB-TEXT	0	0.010"	CONTINUOUS	Title Block Text
	G-ANNO-SEAL-A	0	0.010"	CONTINUOUS	Architectural Stamps And Seals
	G-ANNO-SEAL-C	0	0.010"	CONTINUOUS	Civil Stamps And Seals
	G-ANNO-SEAL-E	0	0.010"	CONTINUOUS	Electrical Stamps And Seals
	G-ANNO-SEAL-M	0	0.010"	CONTINUOUS	Mechanical Stamps And Seals
	G-ANNO-SEAL-S	0	0.010"	CONTINUOUS	Structural Stamps And Seals
Modifier	G-ANNO-SEAL-X-XXX	0	0.010"	CONTINUOUS	Optional - Add Three Initials to the end of the Level Name to separate stamps in one discipline
	G-ANNO-STMP	0	0.010"	CONTINUOUS	Misc. Project Stamps
Details					
	G-DETL-LW00	14	0.004"	CONTINUOUS	Detail Component Level for all objects that are color 9
	G-DETL-LW01	3	0.010"	CONTINUOUS	Detail Component Level for



DISCIPLINE GROUP	LEVEL NAME	MicroStation COLOR	WEIGHT (INCHES)	LINE TYPE	DESCRIPTION
					all objects that are color 1
	G-DETL-LW02	4	0.014"	CONTINUOUS	Detail Component Level for all objects that are color 2
	G-DETL-LW03	2	0.020"	CONTINUOUS	Detail Component Level for all objects that are color 3
	G-DETL-LW04	7	0.028"	CONTINUOUS	Detail Component Level for all objects that are color 4
	G-DETL-LW05	1	0.039"	CONTINUOUS	Detail Component Level for all objects that are color 5
Modifier	G-DETL-SC50	9	0.014"	CONTINUOUS	Example Level Name for 50% Screened items
	G-ANNO-NOTE	0	0.010"	CONTINUOUS	Detail Level for all Notations
	G-ANNO-DIMS-XXXX	10	0.007"	CONTINUOUS	Dimensions (replace the XXXX with the dimscale in use Example: G-ANNO-DIMS-0096 for 1/8"
Optional Modifier	G-XXXX-XXXX-CEN2	4	0.014"	CENTER2	For Center2 Linetype
Optional Modifier	G-XXXX-XXXX-DAS2	4	0.014"	DASHED2	For Dashed2 Linetype
Optional Modifier	G-XXXX-XXXX-MCUT	2	0.020"		For Line Cut By View
Schedules					
	G-SCHD-LW00	14	0.004"	CONTINUOUS	Schedule Component Level for all objects that are color 9
	G-SCHD-LW01	3	0.010"	CONTINUOUS	Schedule Component Level for all objects that are color 1
	G-SCHD-LW02	4	0.014"	CONTINUOUS	Schedule Component Level for all objects that are color 2
	G-SCHD-LW03	2	0.020"	CONTINUOUS	Schedule Component Level for all objects that are color 3
	G-SCHD-LW04	7	0.028"	CONTINUOUS	Schedule Component Level for all objects that are color 4
	G-SCHD-LW05	1	0.039"	CONTINUOUS	Schedule Component Level for all objects that are color 5
Modifier	G-SCHD-SC50	9	0.014"	CONTINUOUS	Example Level Name for 50% Screened items
	G-ANNO-NOTE	0	0.010"	CONTINUOUS	Schedule Level for all Notations
	G-ANNO-DIMS-XXXX	10	0.007"	CONTINUOUS	Dimensions (replace the XXXX with the dimscale in use Example: G-ANNO-DIMS-0096 for 1/8"
Optional Modifier	G-XXXX-XXXX-CEN2	4	0.014"	CENTER2	For Center2 Linetype



DISCIPLINE GROUP	LEVEL NAME	MicroStation COLOR	WEIGHT (INCHES)	LINE TYPE	DESCRIPTION
Optional Modifier	G-XXXX-XXXX-DAS2	4	0.014"	DASHED2	For Dashed2 Linetype
Optional Modifier	G-XXXX-XXXX-MCUT	2	0.020"		For Line Cut By View
Sections					
	G-SECT-LW00	14	0.004"	CONTINUOUS	Section Component Level for all objects that are color 9
	G-SECT-LW01	3	0.010"	CONTINUOUS	Section Component Level for all objects that are color 1
	G-SECT-LW02	4	0.014"	CONTINUOUS	Section Component Level for all objects that are color 2
	G-SECT-LW03	2	0.020"	CONTINUOUS	Section Component Level for all objects that are color 3
	G-SECT-LW04	7	0.028"	CONTINUOUS	Section Component Level for all objects that are color 4
	G-SECT-LW05	1	0.039"	CONTINUOUS	Section Component Level for all objects that are color 5
Modifier	G-SECT-SC50	9	0.014"	CONTINUOUS	Example Level Name for 50% Screened items
	G-ANNO-NOTE	0	0.010"	CONTINUOUS	Section Level for all Notations
	G-ANNO-DIMS-XXXX	10	0.007"	CONTINUOUS	Dimensions (replace the XXXX with the dimscales in use Example: G-ANNO-DIMS-0096 for 1/8"
Optional Modifier	G-XXXX-XXXX-CEN2	4	0.014"		For Center2 Linetype
Optional Modifier	G-XXXX-XXXX-DAS2	4	0.014"		For Dashed2 Linetype
Optional Modifier	G-XXXX-XXXX-MCUT	2	0.020"		For Line Cut By View
Elevations					
	G-ELEV-LW00	14	0.004"	CONTINUOUS	Elevation Component Level for all objects that are color 9
	G-ELEV-LW01	3	0.010"	CONTINUOUS	Elevation Component Level for all objects that are color 1
	G-ELEV-LW02	4	0.014"	CONTINUOUS	Elevation Component Level for all objects that are color 2
	G-ELEV-LW03	2	0.020"	CONTINUOUS	Elevation Component Level for all objects that are color 3
	G-ELEV-LW04	7	0.028"	CONTINUOUS	Elevation Component Level for all objects that are color 4



DISCIPLINE GROUP	LEVEL NAME	MicroStation COLOR	WEIGHT (INCHES)	LINE TYPE	DESCRIPTION
	G-ELEV-LW05	1	0.039"	CONTINUOUS	Elevation Component Level for all objects that are color 5
Modifier	G-ELEV-SC50	9	0.014"	CONTINUOUS	Example Level Name for 50% Screened items
	G-ANNO-NOTE	0	0.010"	CONTINUOUS	Elevation Level for all notations
	G-ANNO-DIMS-XXXX	10	0.007"	CONTINUOUS	Dimensions (replace the XXXX with the dimscales in use Example: G-ANNO-DIMS-0096 for 1/8"
Optional Modifier	G-XXXX-XXXX-CEN2	4	0.014"	CENTER2	For Center2 Linetype
Optional Modifier	G-XXXX-XXXX-DAS2	4	0.014"	DASHED2	For Dashed2 Linetype
Optional Modifier	G-XXXX-XXXX-MCUT	2	0.020"		For Line Cut By View
Modifier	X-XXXX-XXXX-DEMO	VARIABLES	VARIABLES	HIDDEN2	Any Level Name: Existing Work To Be Demolished
Modifier	X-XXXX-XXXX-EXIS	VARIABLES	VARIABLES	CONTINUOUS	Any Level Name: Existing Work To Remain
Modifier	X-XXXX-XXXX-INTR	VARIABLES	VARIABLES	CONTINUOUS	Interior Level Modifier
Modifier	X-XXXX-XXXX-EXTR	VARIABLES	VARIABLES	CONTINUOUS	Exterior Level Modifier
Modifier	X-XXXX-XXXX-SC50	9	VARIABLES	CONTINUOUS	Screened Level Modifier for 50% screen
Modifier	X-XXXX-XXXX-EXIS	VARIABLES	VARIABLES	CONTINUOUS	Any Level Name: Existing Work To Remain
Modifier	X-XXXX-XXXX-EXIS	VARIABLES	VARIABLES	CONTINUOUS	Any Level Name: Existing Work To Remain
Modifier	X-XXXX-XXXX-XXXX-P	VARIABLES	VARIABLES	HIDDEN2	Proposed Work
Modifier	X-XXXX-XXXX-XXXX-E	VARIABLES	VARIABLES	CONTINUOUS	Existing to Remain
Modifier	X-XXXX-XXXX-XXXX-D	VARIABLES	VARIABLES	CONTINUOUS	Existing to be Demolished
Modifier	X-XXXX-XXXX-XXXX-F	VARIABLES	VARIABLES	CONTINUOUS	Future Work
Modifier	X-XXXX-XXXX-XXXX-T	VARIABLES	VARIABLES	CONTINUOUS	Temporary Work
Modifier	X-XXXX-XXXX-XXXX-M	VARIABLES	VARIABLES	CONTINUOUS	Items to be Moved
Modifier	X-XXXX-XXXX-XXXX-X	VARIABLES	VARIABLES	CONTINUOUS	Not in Contract



DISCIPLINE GROUP	LEVEL NAME	MicroStation COLOR	WEIGHT (INCHES)	LINE TYPE	DESCRIPTION
Civil - BASEMAP					
	C-BLDG	1	0.039"	CONTINUOUS	Buildings And Structures
	C-BLDG-ANNO	109	0.010"	CONTINUOUS	Building Bubbles And Text
	C-BLDG-EQUP	29	0.010"	DASHED2	Building Equipment
	C-BLDG-GRID	109	0.010"	CENTER2	Building Column Grids
	C-BLIN	3	0.010"	CONTINUOUS	Baseline
	C-BLIN-STAN	10	0.007"	CONTINUOUS	Baseline Stationing
	C-BLIN-<NAME>	3	0.010"	CONTINUOUS	Baseline With LDD Baseline Line Name Included
	C-BLIN-<NAME>-STAN	10	0.007"	CONTINUOUS	Baseline With LDD Baseline Line Name Included Stations
	C-BORE	2	0.020"	CONTINUOUS	Borings
	C-BRDG	2	0.020"	CONTINUOUS	Bridge
	C-BRDG-CNTJ	2	0.020"	CONTINUOUS	Bridge Construction Joint
	C-BRDG-EXPJ	2	0.020"	CONTINUOUS	Bridge Expansion Joints
	C-CHAN	2	0.020"	CONTINUOUS	Navigable Channels
	C-CHAN-CNTR	2	0.020"	CENTER2	Navigable Channels Center Line
	C-CTRL	4	0.014"	CONTINUOUS	Control Points
	C-CTRL-BMRK	4	0.014"	CONTINUOUS	Control Point Benchmarks
	C-CTRL-CNTR	179	0.010"	CENTER2	Control Center Lines
	C-CTRL-LIMIT	132	0.028"	PHANTOM2	Control Work Limits
	C-CTRL-STAT	0	0.010"	CONTINUOUS	Control Stationing
	C-CTRL-TANG	179	0.010"	HIDDEN2	Control Tangents
	C-CTRL-TRAV	4	0.014"	CONTINUOUS	Control Points Traverse
	C-DEMO	2	0.020"	CONTINUOUS	Demolition
	C-DRIV	2	0.020"	CONTINUOUS	Driveway
	C-DRIV-CURB	2	0.020"	CONTINUOUS	Driveway Curb



DISCIPLINE GROUP	LEVEL NAME	MicroStation COLOR	WEIGHT (INCHES)	LINE TYPE	DESCRIPTION
	C-DRIV-CURB-BACK	10	0.007"	CONTINUOUS	Driveway Curb Back Of Curb
	C-DRIV-CURB-FACE	2	0.020"	CONTINUOUS	Driveway Curb Face Of Curb
	C-DTCH	2	0.020"	CONTINUOUS	Ditch
	C-DTCH-CNTR	2	0.020"	CENTER2	Ditch Centerline
	C-EROS	2	0.020"	HIDDEN2	Erosion And Sediment Control
	C-EROS-ANNO	10	0.007"	CONTINUOUS	Erosion And Sediment Controlv Fence
	C-ESMT	126	0.020"	DASH2	Easement Lines
	C-ESMT-ANNO	0	0.010"	CONTINUOUS	Easement Line Texts
	C-ESMT-RWAY	2	0.020"	DASHED2	Easement Line Roadway
	C-ESMT-UTIL	2	0.020"	DASHED2	Easement Roadway Utilities
	C-FENC	46	0.020"	FENCE_X	Fence Line & Gates
	C-FLHA	2	0.020"	CUSTOM	Flood Hazard
	C-FLHA-100Y	2	0.020"	CUSTOM	Flood Hazard 100 Year Line
	C-GRAL	2	0.020"	CUSTOM	Guard Rails
	C-PERC	4	0.014"	CONTINUOUS	Perc Test Pits
	C-PERC-ANNO	0	0.010"	CONTINUOUS	Perc Test Pits Text
	C-PLST	10	0.007"	CONTINUOUS	Plan Sheet Index Layout
	C-POND	10	0.007"	CONTINUOUS	Ponds
	C-POND-ANNO	0	0.010"	CONTINUOUS	Ponds Text
	C-PRKG-ASPH	88	0.014"	CONTINUOUS	Parking Lot Asphalt Pavement
	C-PRKG-CONC	4	0.014"	CONTINUOUS	Parking Lot Concrete Pavement
	C-PRKG-CURB	2	0.020"	CONTINUOUS	Parking Lot Curb
	C-PRKG-CURB-BACK	10	0.007"	CONTINUOUS	Parking Lot Back Of Curb



DISCIPLINE GROUP	LEVEL NAME	MicroStation COLOR	WEIGHT (INCHES)	LINE TYPE	DESCRIPTION
	C-PRKG-CURB-FACE	2	0.020"	CONTINUOUS	Parking Lot Face Of Curb
	C-PRKG-GRVL	0	0.010"	CONTINUOUS	Parking Lot Gravel Pavement
	C-PRKG-SIGN	4	0.014"	CONTINUOUS	Parking Lot Signage
	C-PRKG-STRP	29	0.010"	CONTINUOUS	Parking Lot Striping
	C-PROP-ANNO	0	0.010"	CONTINUOUS	Property Line Texts
	C-PROP-BNDY	10	0.007"	CUSTOM	Property - Boundary Line, Township, City, County, Etc.
	C-PROP-LINE	38	0.028"	PHANTOM2	Property Lines
	C-PROP-MONU	2	0.020"	CONTINUOUS	Property Monuments
	C-PROP-ROWA	7	0.028"	CUSTOM	Property Right Of Way Line
	C-PROP-ROWD	0	0.010"	CONTINUOUS	Property Right Of Way Deed Information
	C-PVMT-JOIN	2	0.020"	HIDDEN2	Pavement Joints
	C-PVMT-LONG	198	0.028"	CONTINUOUS	Longitudinal Joints
	C-PVMT-TRAN	27	0.014"	HIDDEN2	Transverse Joints
	C-RAIL	10	0.007"	CUSTOM	Railroad
	C-RAIL-CNTR	10	0.007"	CENTER2	Railroad Centerline
	C-RAIL-TRAK	0	0.010"	CONTINUOUS	Railroad Tracks
	C-RIVR	2	0.020"	CUSTOM	River
	C-RIVR-ANNO	0	0.010"	CONTINUOUS	River Text
	C-RIVR-CNTR	0	0.010"	CENTER2	River Centerline
	C-ROAD	2	0.020"	CONTINUOUS	Roadway
	C-ROAD-ASPH	2	0.020"	CONTINUOUS	Roadway - Asphalt
	C-ROAD-CNTR	2	0.020"	CENTER2	Roadway - Centerlines
	C-ROAD-CONC	2	0.020"	CONTINUOUS	Roadway - Concrete
	C-ROAD-CURB	2	0.020"	CONTINUOUS	Roadway Curb
	C-ROAD-CURB-BACK	10	0.007"	CONTINUOUS	Roadway Back Of Curb
	C-ROAD-CURB-FACE	2	0.020"	CONTINUOUS	Roadway Face Of Curb
	C-ROAD-BARR	2	0.020"	CONTINUOUS	Roadway Barrier Curb
	C-ROAD-GRAD	2	0.020"	CONTINUOUS	Roadway Grading
	C-ROAD-PRGL	2	0.020"	CONTINUOUS	Roadway Profile Grade Line



DISCIPLINE GROUP	LEVEL NAME	MicroStation COLOR	WEIGHT (INCHES)	LINE TYPE	DESCRIPTION
	C-ROAD-SIGN	2	0.020"	CONTINUOUS	Roadway Signs
	C-ROAD-SHDR	2	0.020"	CONTINUOUS	Roadway Shoulder
	C-ROAD-SLOP	2	0.020"	CONTINUOUS	Roadway Slope Line
	C-ROAD-STRP-SOLD	2	0.020"	CONTINUOUS	Roadway Striping
	C-ROAD-STRP-DASH	2	0.020"	CUSTOM	Roadway Striping
	C-SOIL	2	0.020"	CONTINUOUS	Soil Types
	C-SWLK	2	0.020"	CONTINUOUS	Sidewalks
	C-SWLK-ASPH	2	0.020"	CONTINUOUS	Sidewalks - Asphalt
	C-SWLK-CONC	2	0.020"	CONTINUOUS	Sidewalks - Concrete
	C-TINN	10	0.007"	CONTINUOUS	Triangulated Irregular Network
	C-TINN-BNDY	10	0.007"	CONTINUOUS	Triangulated Irregular Network- Boundary
	C-TINN-FALT	10	0.007"	CONTINUOUS	Triangulated Irregular Network- Fault Line
	C-TOPO-DEPR	3	0.010"	CONTINUOUS	Depress Contours
	C-TOPO-DEPR-ANNO	0	0.010"	CONTINUOUS	Depress Cont Text
	C-TOPO-FLOW	3	0.010"	DIVIDE2	Flow Line
	C-TOPO-LIMIT	36	0.014"	PHANTOM2	Limit Of Grading
	C-TOPO-MAJR	199	0.028"	CONTINUOUS	Major Contours
	C-TOPO-MAJR-ANNO	0	0.010"	CONTINUOUS	Major Cont Text
	C-TOPO-MINR	2	0.020"	CONTINUOUS	Minor Contours
	C-TOPO-MINR-ANNO	0	0.010"	CONTINUOUS	Minor Cont Text
	C-TOPO-RIDG	3	0.010"	DASHED2	Ridge Line
	C-TOPO-SPOT	4	0.014"	CONTINUOUS	Spot Elevations
	C-TOPO-TTOS	3	0.010"	HIDDEN2	Top/Toe Of Slope
	C-TREE	10	0.007"	CUSTOM	Trees
	C-TSIG	2	0.020"	CONTINUOUS	Traffic Signals
	C-TSIG-ANNO	0	0.010"	CONTINUOUS	Traffic Signals Text
	C-TSIG-UNDR	2	0.020"	HIDDEN2	Traffic Signals Underground



DISCIPLINE GROUP	LEVEL NAME	MicroStation COLOR	WEIGHT (INCHES)	LINE TYPE	DESCRIPTION
	C-WALL	2	0.020"	CONTINUOUS	Walls
	C-WALL-RTWL	4	0.014"	CONTINUOUS	Retaining Walls
	C-WETL	2	0.020"	CUSTOM	Wetlands
	CG-DEPR	3	0.010"	CONTINUOUS	Depress Contours
	CG-DEPR-ANNO	0	0.010"	CONTINUOUS	Depress Cont Text
	CG-FLOW	3	0.010"	DIVIDE2	Flow Line
	CG-LIMT	36	0.014"	PHANTOM2	Limit Of Grading
	CG-MAJR	199	0.028"	CONTINUOUS	Major Contours
	CG-MAJR-ANNO	0	0.010"	CONTINUOUS	Major Cont Text
	CG-MINR	2	0.020"	CONTINUOUS	Minor Contours
	CG-MINR-ANNO	0	0.010"	CONTINUOUS	Minor Cont Text
	CG-RIDG	3	0.010"	DASHED2	Ridge Line
	CG-SPOT	4	0.014"	CONTINUOUS	Spot Elevations
	CG-TTOS	3	0.010"	HIDDEN2	Top/Toe Of Slope
	CU-CAIR	125	0.020"	CONTINUOUS	Compressed Air
	CU-CAIR-ANNO		0.010"	CONTINUOUS	Air Text
	CU-CAIR-SURF	206	0.020"	CONTINUOUS	Air Surface Items
	CU-CATV	195	0.020"	CONTINUOUS	Cable Tv
	CU-CATV-ANNO	0	0.010"	CONTINUOUS	Cable Text
	CU-CATV-SURF	206	0.020"	CONTINUOUS	Cable Tv Surface Items
	CU-CATV-UNDR	2	0.020"	CUSTOM	Cable Tv Underground
	CU-COMM	205	0.020"	CONTINUOUS	Communication
	CU-COMM-ANNO	0	0.010"	CONTINUOUS	Comm Text
	CU-COMM-SURF	206	0.020"	CONTINUOUS	Comm Surface Items
	CU-COMM-UNDR	2	0.020"	CUSTOM	Communication Underground



DISCIPLINE GROUP	LEVEL NAME	MicroStation COLOR	WEIGHT (INCHES)	LINE TYPE	DESCRIPTION
	CU-FIRE	119	0.028"	CONTINUOUS	Fire Protection
	CU-FIRE-ANNO	0	0.010"	CONTINUOUS	Fire Protection Text
	CU-FIRE-HYDR	2	0.020"	CONTINUOUS	Fire Protection Hydrants
	CU-FIRE-SURF	206	0.020"	CONTINUOUS	Fire Protection Surface Items
	CU-FIRE-UNDR	2	0.020"	CUSTOM	Fire Protection Underground
	CU-FUEL	2	0.020"	CUSTOM	Fuel Gas
	CU-FUEL-TANK	2	0.020"	HIDDEN2	Fuel Gas Tank
	CU-FUEL-UNDR	2	0.020"	CUSTOM	Fuel Gas Underground
	CU-LITE	2	0.020"	CONTINUOUS	Lighting
	CU-NGAS	2	0.020"	CONTINUOUS	Natural Gas
	CU-NGAS-ANNO	0	0.010"	CONTINUOUS	Natural Gas Text
	CU-NGAS-SURF	206	0.020"	CONTINUOUS	Natural Gas Surface Items
	CU-NGAS-UNDR	2	0.020"	CUSTOM	Natural Gas Underground
	CU-POWR	45	0.020"	CONTINUOUS	Power
	CU-POWR-ANNO	0	0.010"	CONTINUOUS	Power Text
	CU-POWR-SURF	206	0.020"	CONTINUOUS	Power Surface Items
	CU-POWR-UNDR	2	0.020"	CUSTOM	Power Underground
	CU-RECL	132	0.028"	CONTINUOUS	Reclaimed Water
	CU-RECL-ANNO	0	0.010"	CONTINUOUS	Rw Text
	CU-RECL-SURF	206	0.020"	CONTINUOUS	Rw Surface Items
	CU-SSWR	118	0.028"	CONTINUOUS	Sanitary Sewer
	CU-SSWR-ANNO	0	0.010"	CONTINUOUS	Sanitary Sewer Text
	CU-SSWR-SURF	206	0.020"	CONTINUOUS	Sanitary Sewer Surface Items
	CU-SSWR-UNDR	2	0.020"	CUSTOM	Sanitary Sewer Underground
	CU-STRM	119	0.028"	CONTINUOUS	Storm Drain Lines
	CU-STRM-ANNO	0	0.010"	CONTINUOUS	Storm Drain Text



DISCIPLINE GROUP	LEVEL NAME	MicroStation COLOR	WEIGHT (INCHES)	LINE TYPE	DESCRIPTION
	CU-STRM-STRC	2	0.020"	CONTINUOUS	Storm Drain Structures
	CU-STRM-SURF	206	0.020"	CONTINUOUS	Storm Drain Surface Items
	CU-STRM-UNDR	2	0.020"	CUSTOM	Storm Drain Underground
	CU-TELE	2	0.020"	CUSTOM	Telephone
	CU-TELE-ANNO	0	0.010"	CONTINUOUS	Telephone Text
	CU-TELE-SURF	206	0.020"	CUSTOM	Telephone Surface Items
	CU-TELE-UNDR	2	0.020"	CUSTOM	Telephone Underground
	CU-WATR	7	0.028"	CONTINUOUS	Water
	CU-WATR-ANNO	0	0.010"	CONTINUOUS	Water Text
	CU-WATR-SURF	206	0.020"	CONTINUOUS	Water Surface Items
	CU-WATR-UNDR	2	0.020"	CUSTOM	Water Underground
	CU-WATR-WELL	2	0.020"	HIDDEN2	Water - Well
Landscape					
	L-IRRI-MAIN	1	0.039"	CONTINUOUS	Main Line Irrigation
	L-IRRI-EQPM	4	0.014"	CONTINUOUS	Irrigation: Equipment
	L-IRRI-PIPE	4	0.014"	CONTINUOUS	Piping
	L-IRRI-SPKL	4	0.014"	CONTINUOUS	Sprinkler Heads
	L-PLNT-GCVR	3	0.010"	CONTINUOUS	Groundcovers and Vines
	L-PLNT-SHRB	4	0.014"	CONTINUOUS	Bushes and Shrubs
	L-PLNT-TREE	2	0.020"	CONTINUOUS	Trees
	L-PLNT-IDEN	0	0.010"	CONTINUOUS	Plants And Landscape Identification Notation
	L-PATT-HDSC	10	0.007"	CONTINUOUS	Hardscape Patterning
	L-PATT-LAND	10	0.007"	CONTINUOUS	Landscape Patterning
	L-SYMB-VISB	4	0.014"	CONTINUOUS	Visibility Symbology
	L-SYMB-BLDR	4	0.014"	CONTINUOUS	Bolder Symbology
	L-SYMB-FURN	3	0.010"	CONTINUOUS	Site Furniture Symbology
	L-STRC-RMDA	2	0.020"	CONTINUOUS	Ramada Structures
	L-STRC-WALL	4	0.014"	CONTINUOUS	Wall Structures



DISCIPLINE GROUP	LEVEL NAME	MicroStation COLOR	WEIGHT (INCHES)	LINE TYPE	DESCRIPTION
	L-EDGE	3	0.010"	CONTINUOUS	Boundary Edging
Architectural - GENERAL					
	A-AREA	4	0.014"	CONTINUOUS	Area (Area Calculation)
	A-AREA-OCCP	3	0.010"	CONTINUOUS	Area: Occupant Or Employee Names
	A-AREA-PATT-####	10	0.007"	CONTINUOUS	Area: Pattern (Department/Blocking Diagram- Core Shading Etc.)
	A-AREA-IDEN	0	0.010"	CONTINUOUS	Area: Identification (Room Id, Numbers Etc) -Demo
	A-PEOP	3	0.010"	CONTINUOUS	People, Animals, etc.
	A-SITE	3	0.010"	CONTINUOUS	General Site Elements (Tennis Courts, etc.)
	A-VEHI	3	0.010"	CONTINUOUS	Cars, Planes, Busses and all Other Vehicles
Architectural - FLOOR PLAN					
	A-COLS-PILA	3	0.010"	CONTINUOUS	Architectural Columns And Pilasters
	A-CONV	3	0.010"	CONTINUOUS	Conveying Systems
	A-FLOR-CASE-LOWR	10	0.007"	CONTINUOUS	Floor: Casework: Lower Elements
	A-FLOR-CASE-UPPR	10	0.007"	DASHED2	Floor: Casework: Upper Elements
	A-FLOR-CASE-IDEN	0	0.010"	CONTINUOUS	Floor: Casework Identification
	A-FLOR-EVTR	3	0.010"	CONTINUOUS	Floor: Elevator
	A-FLOR-HIDD	5	0.004"	HIDDEN2	Floor: Hidden Elements
	A-FLOR-HRAL	10	0.007"	CONTINUOUS	Floor: Handrails/Guardrails
	A-FLOR-IDEN	0	0.010"	CONTINUOUS	Floor: Identification
	A-FLOR-LEVL	10	0.007"	CONTINUOUS	Floor: Level Changes, Ramps, Pits, Depressions
	A-FLOR-OTLN	3	0.010"	CONTINUOUS	Floor: Outline
	A-FLOR-OVHD	3	0.010"	HIDDEN2	Floor: Overhead (Objects Above)
	A-FLOR-OPNX	3	0.010"	CONTINUOUS	Openings
	A-FLOR-QRAL	10	0.007"	CONTINUOUS	Queue Rails
	A-FLOR-PATT	5	0.004"	CONTINUOUS	Floor: Pattern



DISCIPLINE GROUP	LEVEL NAME	MicroStation COLOR	WEIGHT (INCHES)	LINE TYPE	DESCRIPTION
	A-FLOR-PATT-SC30	Varies	Varies	CONTINUOUS	Floor: Pattern - 30% Screened
	A-FLOR-PATT-SC15	Varies	Varies	CONTINUOUS	Floor: Pattern - 15% Screened
	A-FLOR-RAIS	10	0.007"	CONTINUOUS	Floor: Raised Floor
	A-FLOR-SIGN	3	0.010"	CONTINUOUS	Floor: Signs
	A-FLOR-SPCL	3	0.010"	CONTINUOUS	Floor: Specialties (Toilet Room Accessories, Display Cases)
	A-FLOR-STRS	10	0.007"	CONTINUOUS	Floor: Stair Treads/Escalators/Ladders
	A-FLOR-TPTN	10	0.007"	CONTINUOUS	Floor: Toilet Partitions
	A-PRKG-FIXT	10	0.007"	CONTINUOUS	Building Parking: Wheel Stops
	A-PRKG-MRKG	10	0.007"	CONTINUOUS	Building Parking: Pavement Markings
	A-PRKG-SIGN	10	0.007"	CONTINUOUS	Building Parking: Signs, H.C. Signs
	A-PRKG-STRP	10	0.007"	CONTINUOUS	Building Parking : Striping
	A-DOOR	10	0.007"	CONTINUOUS	Doors
	A-DOOR-SILL	5	0.004"	CONTINUOUS	Door Sill
	A-DOOR-IDEN	0	0.010"	CONTINUOUS	Door Identification
	A-DOOR-GLAZ	10	0.007"	CONTINUOUS	Door Glazing
	A-GLAZ	10	0.007"	CONTINUOUS	Glazing
	A-GLAZ-ASSM	10	0.007"	CONTINUOUS	Glazing Assemblies
	A-GLAZ-FULL	3	0.010"	CONTINUOUS	Glazing: Full Height
	A-GLAZ-IDEN	0	0.010"	CONTINUOUS	Glazing: Identification Notation
	A-GLAZ-MULL	4	0.014"	CONTINUOUS	Glazing: Mullions
	A-GLAZ-SILL	5	0.004"	CONTINUOUS	Glazing: Sill
	A-GLAZ-TREA	3	0.010"	CONTINUOUS	Glazing: Window Treatments
	A-WALL-CHAS	0	0.010"	CONTINUOUS	Wall: Chase Opening
	A-WALL-CMUN	4	0.014"	CONTINUOUS	Wall: Non-Load Bearing: Concrete Masonry Units
	A-WALL-COMP	5	0.004"	CONTINUOUS	Wall: Components in walls - Studs
	A-WALL-FIRE-1HOR	3	0.010"	CENTER2	Wall: Fire Rated: 1 Hour (3" Thick Polyline)
	A-WALL-FIRE-2HOR	3	0.010"	PHANTOM2	Wall: Fire Rated: 2 Hours (3"



DISCIPLINE GROUP	LEVEL NAME	MicroStation COLOR	WEIGHT (INCHES)	LINE TYPE	DESCRIPTION
					Thick Polyline)
	A-WALL-FIRE-3HOR	3	0.010"	BORDER2	Wall: Fire Rated: 3 Hours (3" Thick Polyline)
	A-WALL-FIRE-4HOR	3	0.010"	DASHED2	Wall: Fire Rated: 4 Hours (3" Thick Polyline)
	A-WALL-FIRE-PATT	5	0.004"	CONTINUOUS	Wall: Fire Rated: Patterning
	A-WALL-FNSH	5	0.004"	CONTINUOUS	Wall: Finishes
	A-WALL-FULL	4	0.014"	CONTINUOUS	Wall: Full Height
	A-WALL-GYPB	3	0.010"	CONTINUOUS	Wall: Gypsum Board
	A-WALL-HEAD	3	0.010"	CONTINUOUS	Wall: Headers
	A-WALL-IDEN	0	0.010"	CONTINUOUS	Wall: Identification
	A-WALL-JAMB	4	0.014"	CONTINUOUS	Wall: Jambs
	A-WALL-MOVE	10	0.007"	CONTINUOUS	Wall: Movable
	A-WALL-MTPL	10	0.007"	CONTINUOUS	Curtain Wall: Metal Panel
	A-WALL-OPEN	0	0.010"	CONTINUOUS	Wall: Opening
	A-WALL-PATT	5	0.004"	CONTINUOUS	Wall: Patterns - Insulation
	A-WALL-PCST	4	0.014"	CONTINUOUS	Curtain Wall: Precast
	A-WALL-PRHT	3	0.010"	CONTINUOUS	Wall: Partial Height
	A-WALL-PROT	10	0.007"	CONTINUOUS	Wall: Protection: Corner Guards, Bumpers
	A-WALL-SMOK	3	0.010"	DOT2	Wall: Smoke Barrier (3" Thick Polyline)
	A-WALL-VENR	10	0.007"	CONTINUOUS	Wall: Veneer
Modifier	S-XXXX-ABLT	3	0.010"	CONTINUOUS	Any Major Group: Anchor Bolts
Modifier	S-XXXX-GRAT	14	0.004"	CONTINUOUS	Any Major Group: Grates
Modifier	S-XXXX-METL	10	0.007"	CONTINUOUS	Any Major Group: Miscellaneous Metals
Modifier	S-XXXX-RBAR	7	0.028"	CONTINUOUS	Any Major Group: Reinforcing Bar
	S-BEAM	7	0.028"	CONTINUOUS	Beams
	S-BEAM-ALUM	104	0.020"	CONTINUOUS	Beams: Aluminum
	S-BEAM-CONC	111	0.020"	CONTINUOUS	Beams: Concrete
	S-BEAM-GLWD	35	0.020"	CONTINUOUS	Beams: Glue Laminated Wood
	S-BEAM-HEAD-WOOD	2	0.020"	CONTINUOUS	Wood Beams, Headers
	S-BEAM-PCST	111	0.020"	CONTINUOUS	Beams: Precast
	S-BEAM-STEL	7	0.028"	CONTINUOUS	Beams: Steel



DISCIPLINE GROUP	LEVEL NAME	MicroStation COLOR	WEIGHT (INCHES)	LINE TYPE	DESCRIPTION
	S-BEAM-WOOD	2	0.020"	CONTINUOUS	Beams: Wood
	S-BRAC	2	0.020"	CONTINUOUS	Bracing
	S-BRAC-ALUM	4	0.014"	CONTINUOUS	Bracing: Aluminum
	S-BRAC-ALUM-HORZ	4	0.014"	DASHED2	Bracing: Aluminum: Horizontal
	S-BRAC-ALUM-VERT	4	0.014"	CONTINUOUS	Bracing: Aluminum: Vertical
	S-BRAC-STEL	191	0.020"	CONTINUOUS	Bracing: Steel
	S-BRAC-STEL-HORZ	191	0.020"	DASHED2	Bracing: Steel: Horizontal
	S-BRAC-STEL-VERT	191	0.020"	CONTINUOUS	Bracing: Steel: Vertical
	S-BRAC-WOOD	2	0.020"	CONTINUOUS	Bracing: Wood
	S-BRAC-WOOD-HORZ	2	0.020"	CONTINUOUS	Bracing: Wood: Horizontal
	S-BRAC-WOOD-VERT	2	0.020"	CONTINUOUS	Bracing: Wood: Vertical
	S-COLS	2	0.020"	CONTINUOUS	Columns
	S-COLS-BELW	10	0.007"	HIDDEN2	Columns Below Floor Plane
	S-COLS-ALUM	104	0.020"	CONTINUOUS	Columns: Aluminum
	S-COLS-CONC	111	0.020"	CONTINUOUS	Columns: Concrete
	S-COLS-PCST	111	0.020"	CONTINUOUS	Columns: Precast Concrete
	S-COLS-STEL	2	0.020"	CONTINUOUS	Columns: Steel
	S-COLS-WOOD	35	0.020"	CONTINUOUS	Columns: Wood
	S-DECK	3	0.010"	CONTINUOUS	Structural Deck
	S-DECK-FLOR	3	0.010"	CONTINUOUS	Structural Deck: Floor
	S-DECK-FLOR-OPNG	0	0.010"	CONTINUOUS	Structural Deck: Floor: Openings And Depressions
	S-DECK-ROOF	3	0.010"	CONTINUOUS	Structural Deck: Roof
	S-DECK-ROOF-OPNG	3	0.010"	CONTINUOUS	Structural Deck: Roof: Openings And Depressions
	S-FLOR-JOIS-CONC	111	0.020"	CENTER2	Floor Joists: Concrete
	S-FLOR-JOIS-STEL	104	0.020"	CENTER2	Floor Joists: Steel
	S-FLOR-JOIS-WOOD	35	0.020"	CENTER2	Floor Joists: Wood
	S-FNDN	2	0.020"	DASHED2	Foundation
	S-FNDN-FTNG	2	0.020"	DASHED2	Foundation: Footings
	S-FNDN-GRBM	42	0.020"	DASHED2	Foundation: Grade Beams
	S-FNDN-PCAP	111	0.020"	DASHED2	Foundation: Pile Caps



DISCIPLINE GROUP	LEVEL NAME	MicroStation COLOR	WEIGHT (INCHES)	LINE TYPE	DESCRIPTION
	S-FNDN-PIER	42	0.020"	DASHED2	Foundation: Drilled Piers
	S-FNDN-PILE	191	0.020"	DASHED2	Foundation: Piles
	S-FNDN-RBAR	111	0.020"	CONTINUOUS	Foundation: Reinforcing
	S-GRDR-CONC	2	0.020"	DASHED2	Girders: Concrete
	S-GRDR-STEL	7	0.028"	CONTINUOUS	Girders: Steel
	S-GRID	10	0.007"	CENTER2	Column Grid
	S-GRID-IDEN	0	0.010"	CONTINUOUS	Column Grid: Identification Bubbles
	S-GRID-EXTR	3	0.010"	CENTER2	Column Grid: Exterior Columns
	S-GRID-INTR	14	0.004"	CENTER2	Column Grid: Interior Columns
	S-JNTS	4	0.014"	CONTINUOUS	Joints
	S-JNTS-CNTJ	4	0.014"	CONTINUOUS	Joints: Construction
	S-JNTS-CTLJ	4	0.014"	CONTINUOUS	Joints: Control
	S-JNTS-EXPJ	4	0.014"	CONTINUOUS	Joints: Expansion
	S-JOIS	35	0.020"	CONTINUOUS	Joists
	S-JOIS-CONC	111	0.020"	CENTER2	Joists: Concrete
	S-JOIS-STEL	104	0.020"	CENTER2	Joists: Steel
	S-JOIS-BRGX	111	0.020"	CONTINUOUS	Joists: Bridging
	S-PADS-CONC	7	0.028"	CONTINUOUS	Concrete Pads For Mechanical Equipment
	S-PATT	9	0.014"	CONTINUOUS	Structural: Pattern
	S-PLWD	4	0.014"	CONTINUOUS	Plywood Sheeting
	S-PURL-STEL	104	0.020"	CONTINUOUS	Purlins: Steel
	S-PURL-WOOD	2	0.020"	CONTINUOUS	Purlins: Wood
	S-RAFT-WOOD	35	0.020"	CONTINUOUS	Rafters: Wood
	S-ROOF-OTLN	3	0.010"	CONTINUOUS	Roof: Outline
	S-SLAB	4	0.014"	CONTINUOUS	Slab



DISCIPLINE GROUP	LEVEL NAME	MicroStation COLOR	WEIGHT (INCHES)	LINE TYPE	DESCRIPTION
	S-SLAB-CONC	4	0.014"	CONTINUOUS	Slab: Concrete
	S-SLAB-EDGE	4	0.014"	CONTINUOUS	Slab: Edge Of Slab
	S-SLAB-OPNG	102	0.014"	CONTINUOUS	Slab: Openings And Depressions
	S-SLAB-OPNX	3	0.010"	CENTER2	Slab: Opening Indication ("X")
	S-SLAB-STEL	107	0.014"	CONTINUOUS	Slab: Steel
	S-SLAB-WOOD	3	0.010"	CONTINUOUS	Slab: Wood
	S-STRS	3	0.010"	CONTINUOUS	Stairs
	S-STRS-CONC	3	0.010"	CONTINUOUS	Stairs: Concrete
	S-STRS-LADD	0	0.010"	CONTINUOUS	Stairs: Ladders & Ladder Assemblies
	S-STRS-STEL	104	0.020"	CONTINUOUS	Stairs: Steel
	S-STRS-WOOD	2	0.020"	CONTINUOUS	Stairs: Wood
	S-TRUS	2	0.020"	CONTINUOUS	Trusses
	S-TRUS-STEL	104	0.020"	CONTINUOUS	Trusses: Steel
	S-TRUS-WOOD	2	0.020"	CONTINUOUS	Trusses: Wood
	S-WALL	3	0.010"	CONTINUOUS	Walls
	S-WALL-BFOG	4	0.014"	HIDDEN2	Walls: Below Floor Or Grade
	S-WALL-CMUW	111	0.020"	CONTINUOUS	Walls: Load Bearing: Concrete Masonry Unit
	S-WALL-CONC	2	0.020"	CONTINUOUS	Walls: Cast-In-Place Concrete
	S-WALL-MSNW	111	0.020"	CONTINUOUS	Walls: Masonry
	S-WALL-PCST	2	0.020"	CONTINUOUS	Walls: Pre-Cast Concrete
	S-WALL-SHEA	2	0.020"	CONTINUOUS	Walls: Shear
	S-WALL-SHEA-CMUW	111	0.020"	CONTINUOUS	Walls: Shear: Concrete Masonry Unit
	S-WALL-SHEA-CONC	2	0.020"	CONTINUOUS	Walls: Shear: Concrete
	S-WALL-SHEA-WOOD	35	0.020"	CONTINUOUS	Walls: Shear: Wood
	S-WALL-STEL	27	0.014"	CONTINUOUS	Walls: Light Gage Steel Studs
	S-WALL-WOOD	111	0.020"	CONTINUOUS	Walls: Wood
	F-AFFF	22	0.014"	CONTINUOUS	Aqueous Film Forming Foam System
	F-AFFF-EQPM	4	0.014"	CONTINUOUS	Aqueous Film Forming Foam: Equipment



DISCIPLINE GROUP	LEVEL NAME	MicroStation COLOR	WEIGHT (INCHES)	LINE TYPE	DESCRIPTION
	F-AFFF-PIPE	46	0.020"	CONTINUOUS	Aqueous Film Forming Foam : Piping
	F-CO2S	102	0.014"	CONTINUOUS	Co2 System
	F-CO2S-EQPM	4	0.014"	CONTINUOUS	Co2 System: Equipment
	F-CO2S-PIPE	102	0.020"	CONTINUOUS	Co2 System: Piping
	F-HALN	182	0.014"	CONTINUOUS	Halon System
	F-HALN-EQPM	4	0.014"	CONTINUOUS	Halon System: Equipment
	F-HALN-PIPE	206	0.020"	CONTINUOUS	Halon System: Piping
	F-IGAS	36	0.014"	CONTINUOUS	Inert Gas System
	F-IGAS-EQPM	4	0.014"	CONTINUOUS	Inert Gas System: Equipment
	F-IGAS-PIPE	44	0.020"	CONTINUOUS	Inert Gas System: Piping
	F-PROT	116	0.014"	CONTINUOUS	Fire Protection System
	F-PROT-ALRM	103	0.014"	CONTINUOUS	Fire Protection System: Alarm
	F-PROT-EQPM	4	0.014"	CONTINUOUS	Fire Protection System: Equipment
	F-PROT-SMOK	27	0.014"	CONTINUOUS	Fire Protection System: Smoke Detectors
	F-PROT-STAN	124	0.020"	CONTINUOUS	Fire Protection System: Standpipe
	F-SPRN	196	0.014"	CONTINUOUS	Sprinkler Systems
	F-SPRN-CLHD	4	0.014"	CONTINUOUS	Sprinkler Systems: Ceiling Heads
	F-SPRN-OTHD	27	0.014"	CONTINUOUS	Sprinkler Systems: Other Heads
	F-SPRN-PIPE	35	0.020"	CONTINUOUS	Sprinkler Systems: Piping
	F-SPRN-STAN	204	0.020"	CONTINUOUS	Sprinkler Systems: Standpipe
Electrical					
	E-XXXX-1LIN	2	0.020"	CONTINUOUS	Any Major Group: Single Line Diagrams
	E-BUSW-1LIN	2	0.020"	CONTINUOUS	Busways: Single Line



DISCIPLINE GROUP	LEVEL NAME	MicroStation COLOR	WEIGHT (INCHES)	LINE TYPE	DESCRIPTION
					Diagrams
	E-EQPM-1LIN	2	0.020"	CONTINUOUS	Equipment: Single Line Diagrams
	E-FEED-1LIN	2	0.020"	CONTINUOUS	Feeders: Single Line Diagrams
	E-XXXX-RISR	2	0.020"	CONTINUOUS	Any Mayor Group: Riser Diagrams
	E-ALRM	2	0.020"	CONTINUOUS	Alarm System
	E-AUXL	2	0.020"	CONTINUOUS	Auxiliary And Miscellaneous Systems
	E-CCTV	2	0.020"	CONTINUOUS	Closed-Circuit Television System
	E-CDEQ	2	0.020"	CONTINUOUS	Control Diagram Wiring And Symbols
	E-COMM	2	0.020"	CONTINUOUS	Telephones, Communication Outlets
	E-CTRL-DEVC	2	0.020"	CONTINUOUS	Electrical Control Systems
	E-DATA	2	0.020"	CONTINUOUS	Data Outlets
	E-FIRE	2	0.020"	CONTINUOUS	Fire Alarm Devices
	E-FIRE-CLNG	2	0.020"	CONTINUOUS	Fire Alarm Devices: Ceiling Mounted
	E-FIRE-WALL	2	0.020"	CONTINUOUS	Fire Alarm Devices: Wall Mounted
	E-FIRE-ZONE	1	0.039"	HIDDEN2	Fire Alarm: Zones
	E-LITE	2	0.020"	CONTINUOUS	Lighting
	E-LITE-CIRC	2	0.020"	CONTINUOUS	Lighting: Circuits: General
	E-LITE-CIRC-C	2	0.020"	CONTINUOUS	Lighting: Circuits: Above Ceiling
	E-LITE-CIRC-NUMB	3	0.010"	CONTINUOUS	Lighting: Circuits: Number
	E-LITE-CIRC-U	2	0.020"	DASHED2	Lighting: Circuits: Below Floor
	E-LITE-CIRC-W	2	0.020"	DASHED2	Lighting: Circuit: Wall
	E-LITE-CLNG	2	0.020"	CONTINUOUS	Lighting: Ceiling Mounted Fixtures
	E-LITE-DEMO	4	0.014"	HIDDEN2	Lighting: Work To Be Demolished
	E-LITE-EMER-C	2	0.020"	CONTINUOUS	Lighting: Emergency: Ceiling Mounted Fixtures
	E-LITE-EMER-W	2	0.020"	CONTINUOUS	Lighting: Emergency: Wall Mounted Fixtures
	E-LITE-EQPM	2	0.020"	CONTINUOUS	Lighting: Equipment
	E-LITE-EXIT-C	2	0.020"	CONTINUOUS	Lighting: Exit: Ceiling



DISCIPLINE GROUP	LEVEL NAME	MicroStation COLOR	WEIGHT (INCHES)	LINE TYPE	DESCRIPTION
					Mounted Fixtures
	E-LITE-EXIT-W	2	0.020"	CONTINUOUS	Lighting: Exit: Wall Mounted Fixtures
	E-LITE-EXTR	2	0.020"	CONTINUOUS	Lighting: Exterior And Site Fixtures
	E-LITE-FLOR	2	0.020"	CONTINUOUS	Lighting: Floor Mounted Fixtures
	E-LITE-IDEN	0	0.010"	CONTINUOUS	Lighting: Fixture Identification Notation
	E-LITE-JBOX	2	0.020"	CONTINUOUS	Lighting: Junction Boxes
	E-LITE-PANL	2	0.020"	CONTINUOUS	Lighting: Panels
	E-LITE-RELO	4	0.014"	CONTINUOUS	Lighting: Work To Be Relocated
	E-LITE-ROOF	2	0.020"	CONTINUOUS	Lighting: Roof Mounted Fixtures
	E-LITE-SPCL	2	0.020"	CONTINUOUS	Lighting: Special Fixtures
	E-LITE-SWCH	2	0.020"	CONTINUOUS	Lighting: Switches And Control Devices
	E-LITE-WALL	2	0.020"	CONTINUOUS	Lighting: Wall Mounted Fixtures
	E-LITE-WDWK	2	0.020"	CONTINUOUS	Lighting: Furniture Mounted, Task Light Fixtures
		2			
	E-LNTG	2	0.020"	DASHED2	Lightning Protection System
		2			
	E-POWR	2	0.020"	CONTINUOUS	Power: Receptacles, Equipment
	E-POWR-CABL	2	0.020"	CONTINUOUS	Power: Cables Trays
	E-POWR-CIRC	2	0.020"	CONTINUOUS	Power: Circuits
	E-POWR-CIRC-C	2	0.020"	CONTINUOUS	Power: Circuits: Above Ceiling
	E-POWR-CIRC-F	2	0.020"	CONTINUOUS	Power: Circuits: Fire Alarm System
	E-POWR-CIRC-NUMB	2	0.020"	CONTINUOUS	Power: Circuits: Number
	E-POWR-CIRC-U	2	0.020"	DASHED2	Power: Circuits: Below Floor
	E-POWR-CIRC-W	2	0.020"	CONTINUOUS	Power: Circuits: Wall
	E-POWR-DEMO	4	0.014"	HIDDEN2	Power: Work To Be Demolished
	E-POWR-DEVC	2	0.020"	CONTINUOUS	Power: Devices
	E-POWR-DCBK	2	0.020"	CONTINUOUS	Power: Duct Banks
	E-POWR-EQPM	2	0.020"	CONTINUOUS	Power: Equipment
	E-POWR-FEED	2	0.020"	CONTINUOUS	Power: Feeders
	E-POWR-JBOX	2	0.020"	CONTINUOUS	Power: Junction Boxes



DISCIPLINE GROUP	LEVEL NAME	MicroStation COLOR	WEIGHT (INCHES)	LINE TYPE	DESCRIPTION
	E-POWR-PANL	2	0.020"	CONTINUOUS	Power: Panels
	E-POWR-SWBD	2	0.020"	CONTINUOUS	Power: Switchboards
	E-POWR-URAC	2	0.020"	DASHED2	Power: Under Floor Raceways
	E-SERT	2	0.020"	CONTINUOUS	Security Systems
	E-SITE	2	0.020"	CONTINUOUS	Site
	E-SITE-UNDR	2	0.020"	DASHED2	Site: Underground Lines
	E-SITE-POLE	2	0.020"	CONTINUOUS	Site: Electric Poles
	E-SITE-OVHD	2	0.020"	CENTER2	Site: Overhead Lines
	E-SOUN	2	0.020"	CONTINUOUS	Sound, P/A Systems, Speakers
	E-TVAN	2	0.020"	CONTINUOUS	Television Antenna System
	T-XXXX-1LIN	4	0.014"	CONTINUOUS	Any Major Group: Single-Line Diagrams
	T-XXXX-RISR	4	0.014"	CONTINUOUS	Any Major Group: Riser Diagrams
	T-CABL	4	0.014"	CONTINUOUS	Cable Systems
	T-CABL-COAX	4	0.014"	CONTINUOUS	Cable Systems: Coaxial Cable
	T-CABL-EQPM	4	0.014"	CONTINUOUS	Cable Systems: Equipment
	T-CABL-FIBR	4	0.014"	CONTINUOUS	Cable Systems: Fiber Optics Cable
	T-CABL-JACK	4	0.014"	CONTINUOUS	Cable Systems: Jacks
	T-CABL-JBOX	4	0.014"	CONTINUOUS	Cable Systems: Junction Boxes
	T-CABL-MULT	4	0.014"	CONTINUOUS	Cable Systems: Multi-Conductor Cable
	T-CABL-TRAY	4	0.014"	CONTINUOUS	Cable Systems: Cable Ray And Wireway
	T-CATV	4	0.014"	CONTINUOUS	Cable Television Systems
	T-DATA	4	0.014"	CONTINUOUS	Data/Lan System
	T-DATA-EQPM	4	0.014"	CONTINUOUS	Data/Lan System:



DISCIPLINE GROUP	LEVEL NAME	MicroStation COLOR	WEIGHT (INCHES)	LINE TYPE	DESCRIPTION
					Equipment
	T-DATA-JACKS	4	0.014"	CONTINUOUS	Data/Lan System: Jacks
	T-DATA-JBOX	4	0.014"	CONTINUOUS	Data/Lan System: Junction Boxes
	T-PHON	4	0.014"	CONTINUOUS	Telephone System
	T-PHON-EQPM	4	0.014"	CONTINUOUS	Telephone System: Equipment
	T-PHON-JACK	4	0.014"	CONTINUOUS	Telephone System: Jacks
	T-PHON-JBOX	4	0.014"	CONTINUOUS	Telephone System: Junction Boxes
Security					
	TY-ALRM-1LIN	4	0.014"	CONTINUOUS	Alarm System: Single-Line Diagrams
	TY-ALRM-RISR	4	0.014"	CONTINUOUS	Alarm System: Riser Diagrams
	TY-ALRM	4	0.014"	CONTINUOUS	Alarm System
	TY-ALRM-DURS	4	0.014"	CONTINUOUS	Alarm System: Duress Alarm
	TY-ALRM-EQPM	4	0.014"	CONTINUOUS	Alarm System: Control Equipment, Consoles, Racks, Etc.
	TY-ALRM-IDEN	0	0.010"	CONTINUOUS	Alarm System: Identification Notation
	TY-CCTV	4	0.014"	CONTINUOUS	Closed-Circuit Television System
	TY-ACCS-CARD	4	0.014"	CONTINUOUS	Access Control System: Card Operated
	TY-ACCS-COND	4	0.014"	CONTINUOUS	Access Control System: Conduit
	TY-ACCS-DOOR	4	0.014"	CONTINUOUS	Access Control Systems: Door Control
	TY-NURS	4	0.014"	CONTINUOUS	Nurse Call System
	TY-POWR	4	0.014"	CONTINUOUS	Power Conduit
	TY-CCTV	4	0.014"	CONTINUOUS	Closed-Circuit Television System
	TY-ACCS-CARD	4	0.014"	CONTINUOUS	Access Control System:



DISCIPLINE GROUP	LEVEL NAME	MicroStation COLOR	WEIGHT (INCHES)	LINE TYPE	DESCRIPTION
					Card Operated
	TY-ACCS-COND	4	0.014	CONTINUOUS	Access Control System: Conduit
	TY-ACCSS-DOOR	4	0.014"	CONTINUOUS	Access Control Systems: Door Control
	TY-NURS	4	0.014"	CONTINUOUS	Nurse Call System
	TY-POWR	4	0.014"	CONTINUOUS	Power Conduit



Appendix 7 – Line Weight Plotting Configuration

LINE WEIGHT SPECIFICATION (11X17 size plots)

Line Weight	Thickness(inch)
0	0.0025
1	0.0050
2	0.0075
3	0.0100
4	0.0125
5	0.0150
6	0.0175
7	0.0200
8	0.0250
9	0.0275
10	0.0300
11	0.0325
12	0.0350
13	0.0400
14	0.0425
15	0.0450
16	0.0475
17	0.0500

LINE WEIGHT SPECIFICATION (22X34 size plot)

Line Weight	Thickness(inch)
0	0.0025
1	0.0075
2	0.0125
3	0.0200
4	0.0250
5	0.0300
6	0.0350
7	0.0400
8	0.0475
9	0.0525
10	0.0575
11	0.0625
12	0.0700
13	0.0750
14	0.0800
15	0.0850
16	0.0925
17	0.0975



Appendix 8 – Custom Line Style (LC) Specification

UTILITY CABLE TV	————CATV————	UTILITY LITE	————LITE————LITE—
UTILITY CABLE TV (OH)	————CATV(OH)————	UTILITY LITE ABANDONED	-----LITE-----LITE--
UTILITY CABLE TV ABANDONED	-----CATV-----	UTILITY LITE DEMO	---X---LITE---X---LITE--
UTILITY CABLE TV DEMO	---X---CATV---X---	UTILITY OIL	————O————O———
UTILITY COMMUNICATION	————COMM————	UTILITY OIL ABANDONED	-----O-----O-----
UTILITY COMMUNICATION (OH)	————COMM(OH)————	UTILITY OIL DEMO	---X---O---X---O---X---
UTILITY COMMUNICATION ABANDONED	-----COMM-----	UTILITY SANITARY SEWER	————SS————SS———
UTILITY COMMUNICATION DEMO	---X---COMM---X---	UTILITY SANITARY SEWER ABANDONED	-----SS-----SS-----
UTILITY COMPRESSED AIR	————AIR————	UTILITY SANITARY SEWER DEMO	---X---SS---X---SS-----
UTILITY COMPRESSED AIR ABANDONED	-----AIR-----	UTILITY SIGNAL	————SIG————SIG———
UTILITY COMPRESSED AIR DEMO	---X---AIR---X---	UTILITY SIGNAL ABANDONED	-----SIG-----SIG-----
UTILITY ELECTRIC	————E————E———	UTILITY SIGNAL DEMO	---X---SIG---X---SIG---
UTILITY ELECTRIC (OH)	————E(OH)————	UTILITY STORM DRAIN	————SD————SD———
UTILITY ELECTRIC ABANDONED	-----E(OH)-----	UTILITY STORM DRAIN ABANDONED	-----SD-----SD-----
UTILITY ELECTRIC DEMO	---X---E(OH)---X---	UTILITY STORM DRAIN DEMO	---X---SD---X---SD-----
UTILITY FIBER OPTIC	————FOC————	UTILITY TELEPHONE (OH)	————TEL(OH)————TEL(OH)———
UTILITY FIBER OPTIC (OH)	————FOC(OH)————	UTILITY TELEPHONE (OH) ABANDONED	-----TEL(OH)-----TEL(OH)-----
UTILITY FIBER OPTIC ABANDONED	-----FOC-----	UTILITY TELEPHONE (OH) DEMO	---X---TEL(OH)---X---TEL(OH)---
UTILITY FIBER OPTIC DEMO	---X---FOC---X---	UTILITY TELEPHONE	————TEL————TEL———
UTILITY FIRE WATER	————FW————FW———	UTILITY TELEPHONE ABANDONED	-----TEL(OH)-----TEL(OH)-----
UTILITY FIRE WATER ABANDONED	-----FW-----FW-----	UTILITY TELEPHONE DEMO	---X---TEL---X---TEL---
UTILITY FIRE WATER DEMO	---X---FW---X---FW---	UTILITY TRENCH DRAIN	————TD————TD———
UTILITY FUEL	————FUEL————	UTILITY TRENCH DRAIN ABANDONED	-----TD-----TD-----
UTILITY FUEL ABANDONED	-----FUEL-----	UTILITY TRENCH DRAIN DEMO	---X---TD---X---TD-----
UTILITY FUEL DEMO	---X---FUEL---X---	UTILITY UNDER DRAIN	————UD————UD———
UTILITY GAS	————G————G———	UTILITY UNDER DRAIN ABANDONED	-----UD-----UD-----
UTILITY GAS ABANDONED	-----G-----G-----	UTILITY UNDER DRAIN DEMO	---X---UD---X---UD-----
UTILITY GAS DEMO	---X---G---X---G---	UTILITY UNKNOWN ID	————UNID————UNID———
UTILITY HOT WATER	————HW————HW———	UTILITY UNKNOWN ID (OH)	————UNID(OH)————
UTILITY HOT WATER ABANDONED	-----HW-----HW-----	UTILITY UNKNOWN ID ABANDONED	-----UNID-----UNID-----
UTILITY HOT WATER DEMO	---X---HW---X---HW---	UTILITY UNKNOWN ID DEMO	---X---UNID---X---UNID---
UTILITY INDF	————INDF————INDF———	UTILITY WATER	————W————W———
UTILITY INDF ABANDONED	-----INDF-----INDF-----	UTILITY WATER ABANDONED	-----W-----W-----
UTILITY INDF DEMO	---X---INDF---X---INDF---	UTILITY WATER DEMO	---X---W---X---W---X---
UTILITY IRRIGATION	————IRR————IRR———		
UTILITY IRRIGATION ABANDONED	-----IRR-----IRR-----		
UTILITY IRRIGATION DEMO	---X---IRR---X---IRR---		



Appendix 9 – Graphic Scales

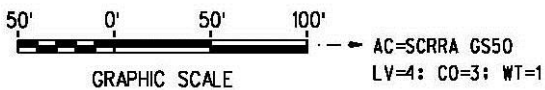
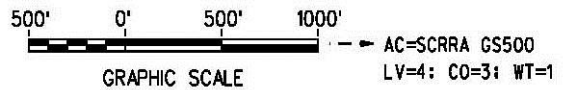
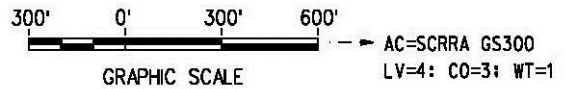
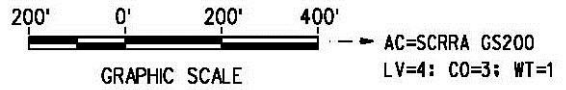
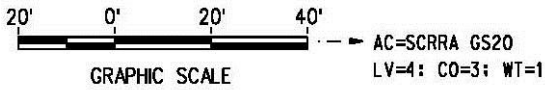
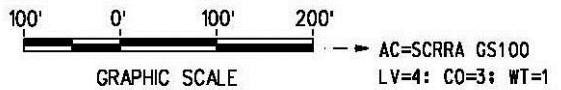
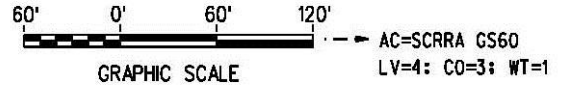
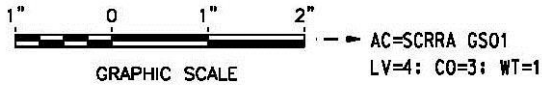



Appendix 10 – Sample SCRRA Border and Title Block

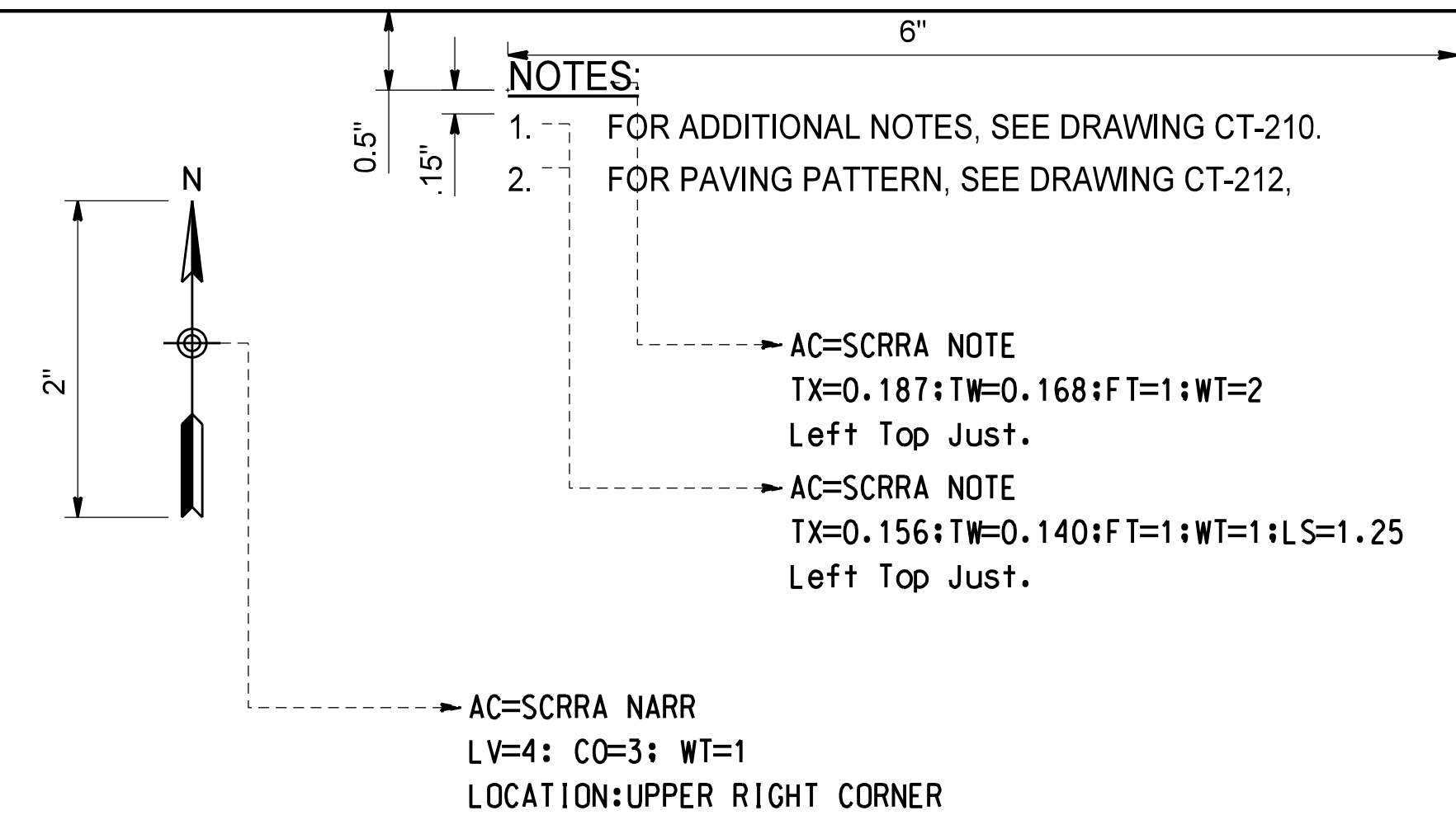

- NOTES:**
- FOR ADDITIONAL NOTES, SEE DRAWING CT-210.
 - FOR PAVING PATTERN, SEE DRAWING CT-212.
- AC=SCRRA NOTE
TX=0.187;TW=0.168;FT=1;WT=2
Left Top Just.
- AC=SCRRA NOTE
TX=0.156;TW=0.140;FT=1;WT=1;LS=1.25
Left Top Just.

AC=SCRRA NARR
LV=4; CO=3; WT=1
LOCATION:UPPER RIGHT CORNER

CONTRACT DRAWING BORDER

CELL=SCRRA BDR

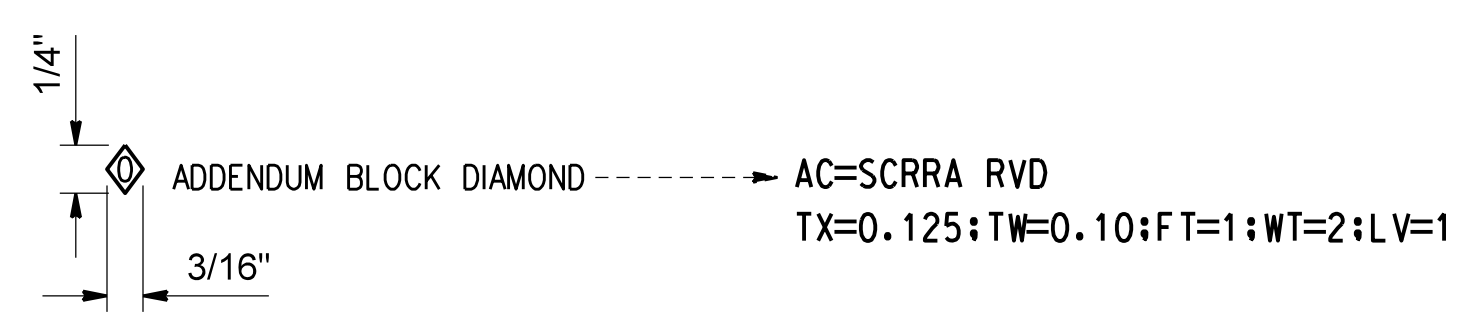
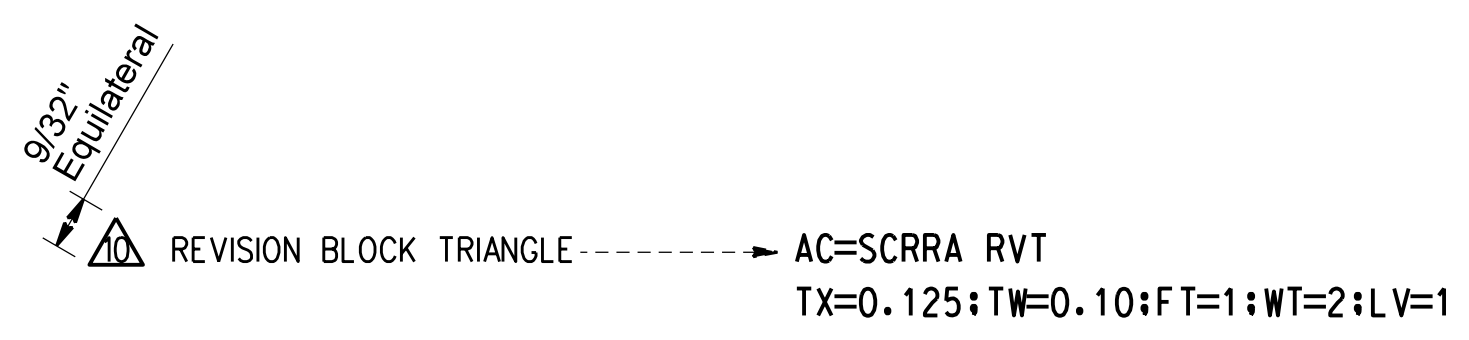
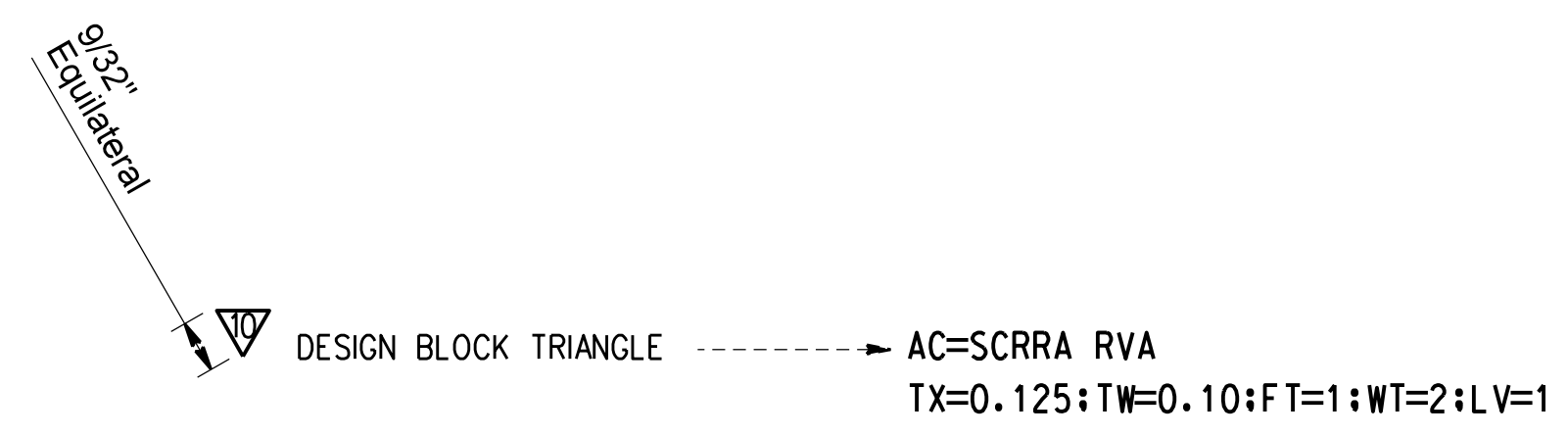

AC=SCRRA RVD
TX=0.125
TW=0.10
FT=1
WT=2
LV=1

AC=SCRRA REV

ENGINEER
RESPONSIBLE/SUBMITTING
CHANGES

PROJECT MANAGER
APPROVING
ADDENDUM/CHANGES

AC=SCRRA BTXT
TX=0.140
TW=0.112
FT=1
WT=2
LV=1
Left Top Just.

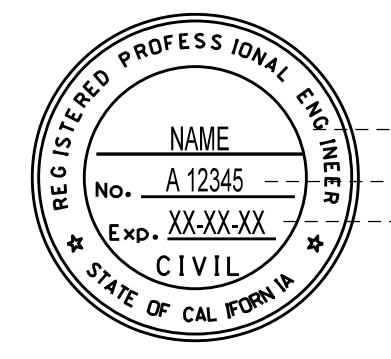

AC=SEAL INFO
TX=0.125
TW=0.08
FT=1
WT=1
LV=7
Center Center Just.

AC=SEAL BLANK CIVIL
LV=7

1 GEC CONSULTANT
(COMPANY NAME AND LOGO)

AC=SCRRA BTXT
TX=0.290
TW=0.232
FT=43
WT=4
LV=1
Center Center Just.

AC=SCRRA BTXT
TX=0.180
TW=0.144
FT=1
WT=3
LV=1
Center Center Just.

AC=SCRRA BTXT
TX=0.180
TW=0.144
FT=1
WT=2
LV=1
Center Center Just.

AC=SCRRA BTXT
TX=0.25
TW=0.20
FT=8
WT=3
LV=1
Center Center Just.

AC=SCRRA BTXT
TX=0.140
TW=0.112
FT=1
WT=2
LV=1
Center Center Just.

RESERVED
FOR
GRAPHIC SCALE,
KEY PLAN OR LEGEND

RESERVED
FOR
SCRRA ADMIN USE

DATES \$USERS \$TIMES \$PLANNING \$SPELDRVLS

REV.	DATE	BY	SUB.	APP.
0	05-04-15			IN
1	09-01-15			IN
2	12-10-15			IN
3	01-14-16			IN

INFORMATION CONFIDENTIAL:
All plans, drawings, specifications, and/or information furnished herewith shall remain the property of the Southern California Regional Rail Authority and shall be held confidential, and shall not be used for any purpose not provided for in agreements with the Southern California Regional Rail Authority.

DESIGNED BY
D. ESIGNER

DRAWN BY
D. RAFTER

CHECKED BY
C. HECKER

APPROVED BY
I. NCHARGE

DATE
05-04-2016

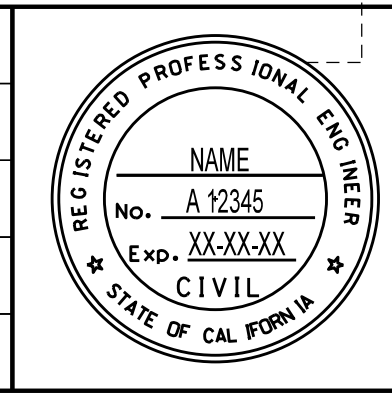

METROLINK

SUBMITTED: _____
PROJECT MANAGER

APPROVED: _____

METROLINK COMMUTER RAIL SYSTEM
METROLINK ANAHEIM STATION
MT1 TRACK PLAN AND
PROFILE MAINLINE
MT1 STA 3151+50 TO MT1 STA 3162+50

CONTRACT NO. C0000-00	
DRAWING NO. XX-000	
REVISION 0	SHEET NO. 000 OF 000
SCALE HORIZ 1"=20' VERT 1"=5'	



Appendix 11 – Sample SCRRA Border And Title Block

CONTRACT DRAWING BORDER

CELL=SCRRA BDR1

AC=SCRRA BTXT
 TX=0.140
 TW=0.112
 FT=1
 WT=2
 LV=1
 Center Center Just.

AC=SCRRA BTXT
 TX=0.180
 TW=0.144
 FT=1
 WT=3
 LV=1
 Center Center Just.

AC=SCRRA BTXT
 TX=0.180
 TW=0.144
 FT=1
 WT=2
 LV=1
 Center Center Just.

AC=SCRRA BTXT
 TX=0.25
 TW=0.20
 FT=8
 WT=3
 LV=1
 Center Center Just.

AC=SCRRA BTXT
 TX=0.140
 TW=0.112
 FT=1
 WT=2
 LV=1
 Left Top Just.

AC=SCRRA BTXT
 TX=0.290
 TW=0.232
 FT=43
 WT=4
 LV=1
 Center Center Just.

RESERVED
 FOR
 GRAPHIC SCALE,
 KEY PLAN OR LEGEND

RESERVED
 FOR
 SCRRA ADMIN USE

1 GEC CONSULTANT
 (COMPANY NAME AND LOGO)

\$DAYS \$USERS
 \$PLT \$LPL \$SPL \$DPL \$VPL \$TDRVL \$

REV.	DATE	BY	SUB.	APP.

INFORMATION CONFIDENTIAL:
 All plans, drawings, specifications, and/or information furnished herewith shall remain the property of the Southern California Regional Rail Authority and shall be held confidential, and shall not be used for any purpose not provided for in agreements with the Southern California Regional Rail Authority.

DESIGNED BY
D. ESIGNER

DRAWN BY
D. RAFTER

CHECKED BY
C. HECKER

APPROVED BY
I. NCHARGE

DATE
XX-XX-XXXX

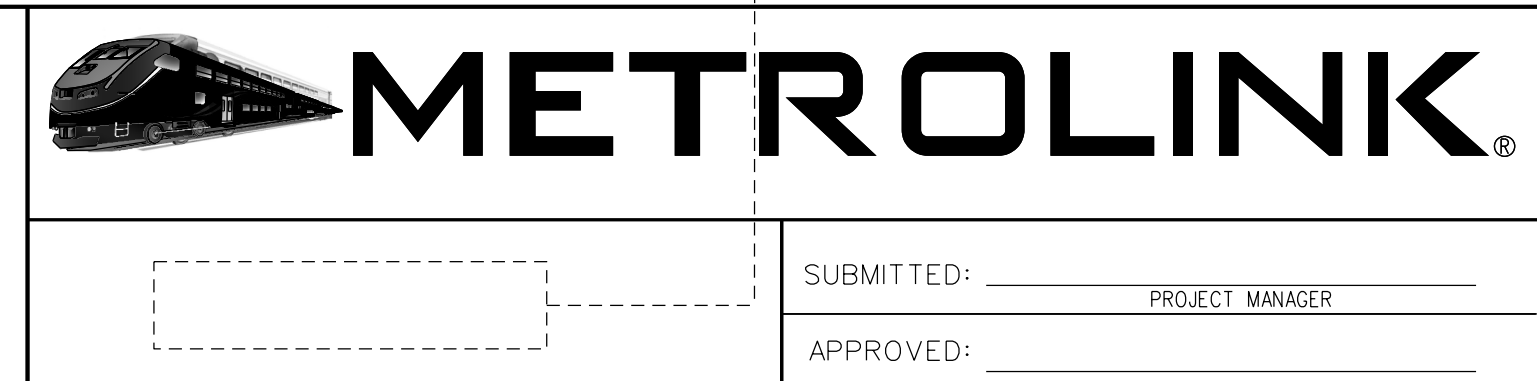
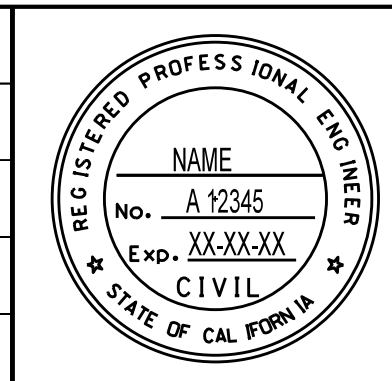

SUBMITTED: _____ PROJECT MANAGER _____

APPROVED: _____

METROLINK COMMUTER RAIL SYSTEM
METROLINK ANAHEIM STATION
 MT1 TRACK PLAN AND
 PROFILE MAINLINE
 MT1 STA 3151+50 TO MT1 STA 3162+50

CONTRACT NO. C0000-00	
DRAWING NO. XX-000	
REVISION	SHEET NO.
0	000 OF 000
SCALE	HORIZ 1"=20' VERT 1"=5'



Appendix 12 – Sample Index of Drawings

INDEX OF DRAWINGS

AC=SCRRA 10D
TX=0.14, TW=0.112, FT=1, WT=2 LV=45

TX=0.25, TW=0.20, FT=8, WT=3, LV=1, Center Center Just.

SHT NO.	DWG. NO.	REV. NO.	TITLE	SHT NO.	DWG. NO.	REV. NO.	TITLE	SHT NO.	DWG. NO.	REV. NO.	TITLE	SHT NO.	DWG. NO.	REV. NO.	TITLE
GENERAL															
1	G-001	0	TITLE SHEET	28	C-028	0	EXISTING TOPOGRAPHY AND DEMOLITION PLAN S12408+50 TO S12419+50	55	C-054	0	ALIGNMENT DATA S12465+00 TO S12493+32.88	83	C-082	0	PROFILE S2 2236+50 TO S2 2258+50
2	G-002	0	INDEX OF DRAWINGS	29	C-029	0	EXISTING TOPOGRAPHY AND DEMOLITION PLAN S12419+50 TO S12430+50	56	C-055	0	PLAN AND PROFILE S12216+86.19 TO S12226+50	84	C-083	0	PROFILE S2 2258+50 TO S2 2278+50
3	G-003	0	GENERAL NOTES SYMBOLS AND ABBREVIATIONS	30	C-030	0	EXISTING TOPOGRAPHY AND DEMOLITION PLAN S12430+50 TO S12441+50	57	C-056	0	PLAN AND PROFILE S12226+50 TO S12236+50	85	C-084	0	PROFILE S2 2278+50 TO S2 2288+50
4	G-004	0	CONSTRUCTION NOTES	31	C-031	0	EXISTING TOPOGRAPHY AND DEMOLITION PLAN S12441+50 TO S12452+00	58	C-057	0	PLAN AND PROFILE S12236+50 TO S12247+50	86	C-085	0	PROFILE S2 2278+50 TO S2 2298+50
5	G-005	0	SURVEY CONTROL SHEET	32	C-032	0	EXISTING TOPOGRAPHY AND DEMOLITION PLAN S12452+00 TO S12462+50	59	C-058	10	PLAN AND PROFILE S12247+50 TO S12258+50	87	C-086	0	ALIGNMENT PLAN COMM EASEMENT BASELINE ("CE" LINE) SHEET 1 OF 2
6	G-006	0	CONSTRUCTION DETAILS AND TYPICAL SECTIONS	33	C-033	0	EXISTING TOPOGRAPHY AND DEMOLITION PLAN S12462+50 TO S12472+50	60	C-059	0	PLAN AND PROFILE S12258+50 TO S12269+50	88	C-087	0	ALIGNMENT PLAN COMM EASEMENT BASELINE ("CE" LINE) SHEET 2 OF 2
CIVIL															
7	CS-001	0	GENERAL CIVIL NOTES, ABBREVIATIONS AND SYMBOLS SHEET 1 OF 2	34	C-034	0	EXISTING TOPOGRAPHY AND DEMOLITION PLAN S12472+50 TO S12483+50	61	C-060	0	PLAN AND PROFILE S12269+50 TO S12278+50	89	C-088	0	SITE PLAN ANAHEIM STATION WEST PARKING LOT AND TRACTION POWER SUBSTATION SFM
8	CS-002	0	GENERAL CIVIL NOTES, ABBREVIATIONS AND SYMBOLS SHEET 2 OF 2	35	C-035	0	EXISTING TOPOGRAPHY AND DEMOLITION PLAN S12483+50 TO S12493+30	62	C-061	0	PLAN AND PROFILE S12278+50 TO S12287+25	90	C-089	0	SITE PLAN ANAHEIM STATION EAST PARKING LOT
9	C-001	0	SUPPLEMENTAL CIVIL NOTES, ABBREVIATIONS AND SYMBOLS	36	C-036	0	EXISTING TOPOGRAPHY AND DEMOLITION PLAN ANAHEIM STATION SHEET 1 OF 7	63	C-062	0	PLAN AND PROFILE S12287+25 TO S12298+50	91	C-090	0	SITE PLAN ANAHEIM STATION EAST PARKING LOT
10	C-010	0	EXISTING TOPOGRAPHY AND DEMOLITION PLAN TRACTION POWER SUBSTATION AFM	37	C-037	0	EXISTING TOPOGRAPHY AND DEMOLITION PLAN ANAHEIM STATION SHEET 2 OF 7	64	C-063	0	PLAN AND PROFILE S12298+50 TO S12309+50	92	C-091	0	SITE PLAN TRACTION POWER SUBSTATION SFM
11	C-011	0	EXISTING TOPOGRAPHY AND DEMOLITION PLAN S12216+86.19 TO S12226+50	38	C-038	0	EXISTING TOPOGRAPHY AND DEMOLITION PLAN ANAHEIM STATION SHEET 3 OF 7	65	C-064	0	PLAN AND PROFILE S12309+50 TO S12320+50	93	C-092	0	GENERAL ARRANGEMENT ANAHEIM STATION - WALNUT AVE ENTRANCES
12	C-012	0	EXISTING TOPOGRAPHY AND DEMOLITION PLAN S12226+50 TO S12236+50	39	C-039	0	EXISTING TOPOGRAPHY AND DEMOLITION PLAN ANAHEIM STATION SHEET 4 OF 7	66	C-065	20	PLAN AND PROFILE S12320+50 TO S12331+50	94	C-093	0	ANAHEIM STATION EAST PARKING LOT DRIVEWAY SITE PLAN AND DETAILS
13	C-013	0	EXISTING TOPOGRAPHY AND DEMOLITION PLAN S12236+50 TO S12247+50	40	C-040	0	EXISTING TOPOGRAPHY AND DEMOLITION PLAN ANAHEIM STATION SHEET 5 OF 7	67	C-066	0	PLAN AND PROFILE S12331+50 TO S12342+50	95	C-094	0	ANAHEIM STATION EAST PARKING LOT DRIVEWAY GRADING AND DRAINAGE PLAN
14	C-014	0	EXISTING TOPOGRAPHY AND DEMOLITION PLAN S12247+50 TO S12258+50	41	C-041	0	EXISTING TOPOGRAPHY AND DEMOLITION PLAN ANAHEIM STATION SHEET 6 OF 7	68	C-067	0	PLAN AND PROFILE S12342+50 TO S12353+50	96	C-095	0	GRADING DETAILS
15	C-015	0	EXISTING TOPOGRAPHY AND DEMOLITION PLAN S12273+50 TO S12281+50	42	C-042	0	EXISTING TOPOGRAPHY AND DEMOLITION PLAN ANAHEIM STATION SHEET 7 OF 7	69	C-068	0	PLAN AND PROFILE S12353+50 TO S12364+50	97	C-096	0	ANAHEIM STATION WALNUT AVE - WEST ACCESS ROAD PLANS AND DETAILS
16	C-016	0	EXISTING TOPOGRAPHY AND DEMOLITION PLAN S12281+50 TO S12290+00	43	C-043	0	EXISTING TOPOGRAPHY AND DEMOLITION PLAN ANAHEIM STATION SHEET 1 OF 7	70	C-069	0	PLAN AND PROFILE S12364+50 TO S12375+50	98	CS-051	0	AT GRADE STANDARD CHAIN LINK FENCING
17	C-017	0	EXISTING TOPOGRAPHY AND DEMOLITION PLAN S12290+00 TO S12298+50	44	C-044	0	EXISTING TOPOGRAPHY AND DEMOLITION PLAN ANAHEIM STATION SHEET 2 OF 7	71	C-070	0	PLAN AND PROFILE S12375+50 TO S12386+50	99	CS-062	0	MARKERS UTILITIES AND STATIONING
18	C-018	0	EXISTING TOPOGRAPHY AND DEMOLITION PLAN S12298+50 TO S12309+50	45	C-045	0	EXISTING TOPOGRAPHY AND DEMOLITION PLAN ANAHEIM STATION SHEET 3 OF 7	72	C-071	0	PLAN AND PROFILE S12386+50 TO S12397+50				
19	C-019	0	EXISTING TOPOGRAPHY AND DEMOLITION PLAN S12309+50 TO S12320+50	46	C-046	0	EXISTING TOPOGRAPHY AND DEMOLITION PLAN ANAHEIM STATION SHEET 4 OF 7	73	C-072	0	PLAN AND PROFILE S12397+50 TO S12408+50				
20	C-020	0	EXISTING TOPOGRAPHY AND DEMOLITION PLAN S12320+50 TO S12331+50	47	C-047	0	ALIGNMENT PLAN AND DATA S12240+50 TO S12270+00	74	C-073	0	PLAN AND PROFILE S12408+50 TO S12419+50				
21	C-021	0	EXISTING TOPOGRAPHY AND DEMOLITION PLAN S12331+50 TO S12342+50	48	C-048	0	ALIGNMENT PLAN AND DATA S12270+00 TO S12301+00	75	C-074	0	PLAN AND PROFILE S12419+50 TO S12430+50				
22	C-022	0	EXISTING TOPOGRAPHY AND DEMOLITION PLAN S12342+50 TO S12353+50	49	C-049	0	ALIGNMENT PLAN AND DATA S12301+00 TO S12331+00	76	C-075	0	PLAN AND PROFILE S12430+50 TO S12441+50				
23	C-023	0	EXISTING TOPOGRAPHY AND DEMOLITION PLAN S12353+50 TO S12364+50	50	C-050	0	ALIGNMENT PLAN AND DATA S12331+00 TO S12361+50	77	C-076	0	PLAN AND PROFILE S12441+50 TO S12452+00				
24	C-024	0	EXISTING TOPOGRAPHY AND DEMOLITION PLAN S12364+50 TO S12375+50	51	C-051	0	ALIGNMENT PLAN AND DATA S12361+50 TO S12409+00	78	C-077	0	PLAN AND PROFILE S12452+00 TO S12462+50				
25	C-025	0	EXISTING TOPOGRAPHY AND DEMOLITION PLAN S12375+50 TO S12386+50	52	C-052	0	ALIGNMENT PLAN AND DATA S12409+00 TO S12437+50	79	C-078	0	PLAN AND PROFILE S12462+50 TO S12472+50 S3 2463+28.000 TO S3 2470+94.572				
26	C-026	0	EXISTING TOPOGRAPHY AND DEMOLITION PLAN S12386+50 TO S12397+50	53	C-053	0	ALIGNMENT PLAN AND DATA S12437+50 TO S12465+00	80	C-079	0	PLAN AND PROFILE S12472+50 TO S12483+50				
27	C-027	0	EXISTING TOPOGRAPHY AND DEMOLITION PLAN S12397+50 TO S12408+50	54	C-054	0	ALIGNMENT PLAN S12465+00 TO S12493+32.88	81	C-080	0	PLAN AND PROFILE S12483+50 TO S12493+32.88				
								82	C-081	0	PROFILE S2 2216+86.19 TO S2 2236+50				

CIVIL STANDARDS

UTILITIES

RESERVED
FOR
SCRRA ADMIN USE

\$ DATES \$
 \$ TIMES \$
 \$ SCHEDULES \$
 \$ PERTAINING \$

REV.	DATE	ISSUED FOR BID	CH	IN
0	05-04-15	ISSUED FOR BID		

INFORMATION CONFIDENTIAL:
All plans, drawings, specifications, and/or information furnished herewith shall remain the property of the Southern California Regional Rail Authority and shall be held confidential, and shall not be used for any purpose not provided for in agreements with the Southern California Regional Rail Authority.

DESIGNED BY
D. ESIGNER

DRAWN BY
D. RAFTER

CHECKED BY
C. HECKER

APPROVED BY
I. NCHARGE

DATE
05-04-2016

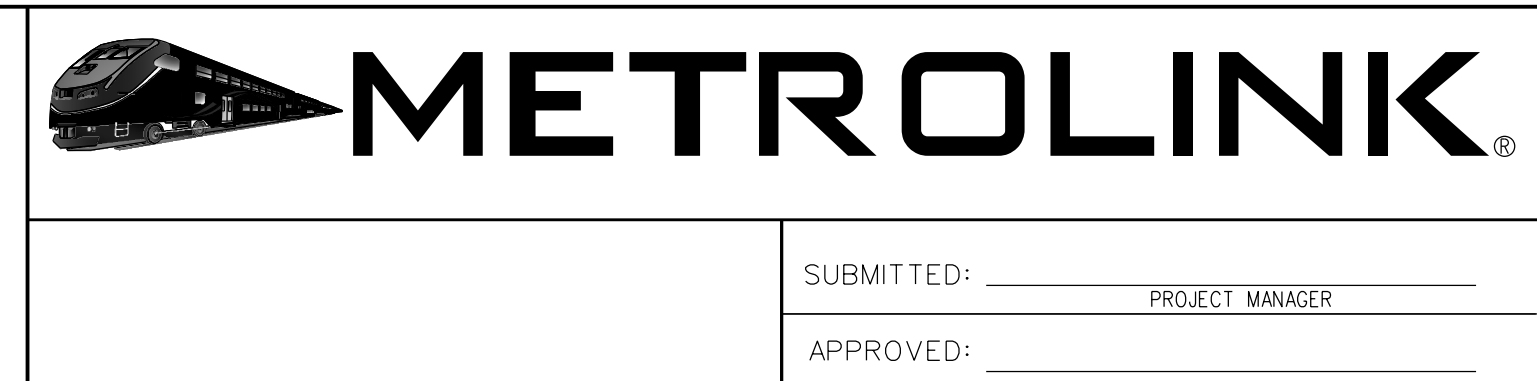
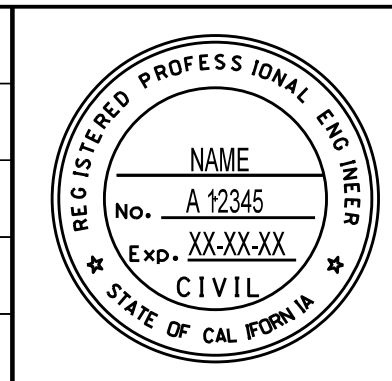

METROLINK COMMUTER RAIL SYSTEM
METROLINK ANAHEIM STATION

INDEX OF DRAWINGS

SUBMITTED: _____ PROJECT MANAGER

APPROVED: _____

CONTRACT NO. C0000-00	
DRAWING NO. XX-000	
REVISION	SHEET NO.
0	000 OF 000
SCALE NO SCALE	



Appendix 13 – Sample Index of Drawings

INDEX OF DRAWINGS

UTILITY AND AGENCY CONTACTS

SYMBOLS AND ABBREVIATIONS

SHT NO.	DWG. NO.	REV. NO.	TITLE	SHT NO.	DWG. NO.	REV. NO.	TITLE
GENERAL							
1	G-001	0	TITLE SHEET	25	C-25	0	SYCAMORE DRIVE STREET IMPROVEMENT PLAN
2	G-002	0	INDEX OF DRAWINGS, SYMBOLS AND ABBREVIATIONS	26	C-26	0	SYCAMORE DRIVE STREET IMPROVEMENT PROFILE
3	G-003	0	GENERAL NOTES AND NOTICES	27	C-27	0	SYCAMORE DRIVE CROSSING IMPROVEMENT DETAIL WEST QUADRANT
4	G-004	0	CONSTRUCTION NOTES	28	C-28	0	SYCAMORE DRIVE MEDIAN DETAIL
5	G-005	0	SURVEY CONTROL SHEET	29	C-29	0	SYCAMORE DRIVE CROSSING IMPROVEMENT DETAIL EAST QUADRANT
6	G-006	0	CONSTRUCTION DETAILS AND TYPICAL SECTIONS	30	C-30	0	SYCAMORE DRIVE UTILITY PLAN
CIVIL ----- TX=0.18, TW=0.144, FT=1, WT=2, LV=45, Left Top Just.							
7	C-07	0	FIRST STREET STREET IMPROVEMENT PLAN	31	C-31	0	SYCAMORE DRIVE DRAINAGE MODIFICATION PLAN
8	C-08	0	FIRST STREET CROSSING IMPROVEMENTS DETAIL	32	C-32	0	SYCAMORE DRIVE LANDSCAPE PLAN
9	C-09	0	FIRST STREET UTILITY PLAN	33	C-33	0	SYCAMORE DRIVE SIGNING AND STRIPING PLAN
10	C-10	0	FIRST STREET SIGNING AND STRIPING	34	C-34	0	SYCAMORE DRIVE TRAFFIC SIGNAL MODIFICATION PLAN
11	C-11	0	ERRINGER ROAD STREET IMPROVEMENT PLAN SHEET 1 OF 2	35	C-35	0	SYCAMORE DRIVE TRAFFIC SIGNAL PREEMPTION PLAN
12	C-12	0	ERRINGER ROAD STREET IMPROVEMENT PLAN SHEET 2 OF 2				
13	C-13	0	ERRINGER ROAD STREET IMPROVEMENT PROFILE SHEET 1 OF 2				
14	C-14	0	ERRINGER ROAD STREET IMPROVEMENT PROFILE SHEET 2 OF 2				
15	C-15	0	ERRINGER ROAD CROSSING IMPROVEMENT DETAIL WEST QUADRANT				
16	C-16	0	ERRINGER ROAD MEDIAN DETAIL				
17	C-17	0	ERRINGER ROAD CROSSING IMPROVEMENT DETAIL EAST QUADRANT				
18	C-18	0	ERRINGER ROAD UTILITY PLAN SHEET 1 OF 2				
19	C-19	0	ERRINGER ROAD UTILITY PLAN SHEET 2 OF 2				
20	C-20	0	ERRINGER ROAD DRAINAGE MODIFICATION PLAN				
21	C-21	0	ERRINGER ROAD LANDSCAPE PLAN				
22	C-22	0	ERRINGER ROAD SIGNING AND STRIPING PLAN				
23	C-23	0	ERRINGER ROAD TRAFFIC SIGNAL MODIFICATION PLAN				
24	C-24	0	ERRINGER ROAD TRAFFIC SIGNAL PREEMPTION PLAN				

SCRRA (METROLINK)	(909) 592-7969 NARESH PATEL
VENTURA COUNTY WATERSHED PROTECTION DISTRICT	(805) 662-6882 KAREN MARTIA
CITY OF SIMIVALLEY WATERWORKS, DISTRICT 8	(805) 583-6896 ERNIE WONG
GOLDEN STATE WATER SIMIVALLEY	(805) 520-2396 SKIP FARIA
AT&T TRANSMISSION	(714) 963-7960 JIM FORKERT
AT&T DISTRIBUTION	(805) 583-6500 JODY RIEHL
CRIMSON PIPELINE L.P.	(562) 285-4102 ALEX MORALES
LEVEL 3 COMMUNICATIONS	(909) 322-0031 JEFF PATRICK
MCI (VERIZON BUSINESS)	(805) 432-6427 ALEC KINCH
QWEST	(714) 666-8016 JUAN DEL CASTILLO
SEMPRA UTILITIES SIMIDISTRICT	(818) 701-4594 PEGGY LI
SPRINT	(951) 662-6262 JACK FRY
SCE DISTRIBUTION THOUSAND OAKS	(714) 796-9932 KIM GURULE
SCE TELECOMMUNICATIONS	(626) 308-6738 CONRAD FROST
SCE TRANSMISSION	(805) 490-5293 BUSTER BROWN
TIME WARNER NORTHWEST	(805) 732-8160 PATRICIA ROBERTSON
SUNESYS, LLC	(951) 235-6021 ROBERT SANTOS
CENTURY LINK BUSINESS	(916) 626-2595 WILLIAM PETERSON

AB	AGGREGATE BASE
AC	ASPHALT CONCRETE
ACP	ASBESTOS CEMENT PIPE
ADA	AMERICANS WITH DISABILITIES ACT
AT&T	AMERICAN TELEPHONE AND TELEGRAPH COMPANY
BC	BEGIN CURVE
BCR	BEGIN CURB RETURN
BM	BENCH MARK
C&G	CURB AND GUTTER
CI	CAST IRON
CH	CURB HEIGHT
CMP	CORRUGATED METAL PIPE
CONC	CONCRETE
CPUC	CALIFORNIA PUBLIC UTILITIES COMMISSION
DI	DRAINAGE INLET
DOT	DEPARTMENT OF TRANSPORTATION (U.S.)
EC	END CURVE
ELEV	ELEVATION
ECR	END OF CURB RETURN
ES	ENGINEERING STANDARDS (SCRRA STANDARD DRAWINGS)
EG	EXISTING GROUND
EXIST	EXISTING
FL	FLOW LINE
FS	FINISHED SURFACE
FT	FEET, FOOT
GB	GRADE BREAK
GPS	GLOBAL POSITIONING SYSTEM
GSW	GOLDEN STATE WATER
HMA	HOT MIX ASPHALT
HP	HIGH PRESSURE
INV	INVERT
JCT	JUNCTION
KV	KILOVOLT
LT	LEFT
LG	LIP OF GUTTER
LP	LOW POINT
MCI	MICROWAVE COMMUNICATIONS INC.
MH	MANHOLE
NAD 83	NORTH AMERICAN DATUM OF 1983
NGS	NATIONAL GEODETIC SURVEY
NSRS	NATIONAL SPATIAL REFERENCE SYSTEM
O.C.	ON CENTER
OG	ORIGINAL GROUND
PPB	PEDESTRIAN PUSH BUTTON
PRE-EMPT	PRE-EMPTION
PROP	PROPOSED
PCC	PORTLAND CEMENT CONCRETE
PH	POT HOLE
PVI	POINT OF VERTICAL INTERSECTION
PVT	POINT OF VERTICAL TANGENT
PVC	POINT OF VERTICAL CURVE
PVRC	POINT OF VERTICAL REVERSE CURVE
RR	RAILROAD
RET	RETAINING
RCB	REINFORCED CONCRETE BOX
RCP	REINFORCED CONCRETE PIPE
ROW	RIGHT-OF-WAY
RPMS	RAISED PAVEMENT MARKERS
RT	RIGHT
RTN	REAL TIME NETWORK
S/W	SIDEWALK
SCRRA	SOUTHERN CALIFORNIA REGIONAL RAIL AUTHORITY
SCE	SOUTHERN CALIFORNIA EDISON
SVPW	SIMIVALLEY DEPARTMENT OF PUBLIC WORKS
SPPWC	STANDARD PLANS FOR PUBLIC WORKS CONSTRUCTION
STA	STATION
SD	STORM DRAIN
SS	STORM SEWER
STD	STANDARD
TC	TOP OF CURB
TG	TOP OF GRATE
TWC	TIME WARNER CABLE
UP	UNION PACIFIC RAILROAD
VC	VERTICAL CURVE
VCTC	VENTURA COUNTY TRANSPORTATION COMMISSION
WGS	WORLD GEODETIC SYSTEM
WSP	WELDED STEEL PIPE
○	NEW CONSTRUCTION
□	DISPOSITION

RESERVED FOR SCRRA ADMIN USE

\$USERS \$TIMES \$DAYS \$SCHEDULES \$SPLDORVLS

0	05-04-15	ISSUED FOR BID	CH	IN
REV.	DATE		BY	APP.

INFORMATION CONFIDENTIAL: All plans, drawings, specifications, and/or information furnished herewith shall remain the property of the Southern California Regional Rail Authority and shall be held confidential, and shall not be used for any purpose not provided for in agreements with the Southern California Regional Rail Authority.

DESIGNED BY	D. ESIGNER
DRAWN BY	D. RAFTER
CHECKED BY	C. HECKER
APPROVED BY	I. NCHARGE
DATE	05-04-2016

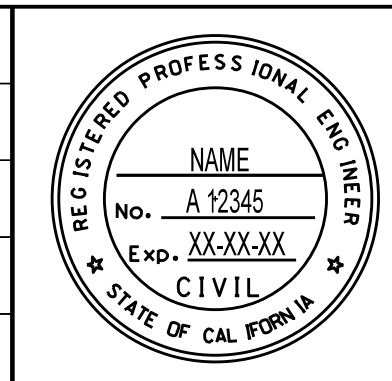

METROLINK COMMUTER RAIL SYSTEM
 VENTURA COUNTY SEALED CORRIDOR

INDEX OF DRAWINGS,
 SYMBOLS AND ABBREVIATIONS

CONTRACT NO.	C0000-00
DRAWING NO.	XX-000
REVISION	0
SHEET NO.	000 OF 000
SCALE	NO SCALE



Appendix 14 – Sample Plan and Profile

AC=SCRRRA PGELEV
 TX=0.125, TW=0.10, FT=8, LV=17,
 CO=0 WT=1, Center Center Just.

AC=SCRRRA PHGRID



STATION 0+00 0+00 0+00 0+00 0+00 0+00 TOTAL

\$USERS
 \$TIMES
 \$DATE
 \$REV
 \$BY
 \$APP
 \$SUB
 \$DATE

REV.	DATE	DESCRIPTION	BY	APP.
0	05-04-15	ISSUED FOR BID	CH	IN

INFORMATION CONFIDENTIAL:
 All plans, drawings, specifications, and/or information furnished herewith shall remain the property of the Southern California Regional Rail Authority and shall be held confidential and shall not be used for any purpose not provided for in agreements with the Southern California Regional Rail Authority.

DESIGNED BY
D. ESIGNER
 DRAWN BY
D. RAFTER
 CHECKED BY
C. HECKER
 APPROVED BY
I. NCHARGE
 DATE
05-04-2016

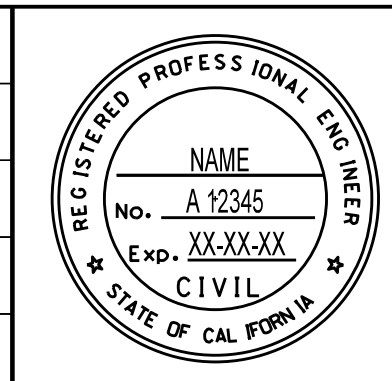

METROLINK COMMUTER RAIL SYSTEM
METROLINK ANAHEIM STATION
MT1 TRACK PLAN AND
PROFILE MAINLINE
MT1 STA 3151+50 TO MT1 STA 3162+50

CONTRACT NO. C0000-00	
DRAWING NO. XX-000	
REVISION 0	SHEET NO. 000 OF 000
SCALE HORIZ 1"=20' VERT 1"=5'	

SUBMITTED: _____ PROJECT MANAGER
 APPROVED: _____



Appendix 15 – Sample Plan and Profile

AC=SCRRRA PGELEV
 TX=0.125, TW=0.10, FT=8, LV=17,
 CO=0 WT=1, Center Center Just.

AC=SCRRRA PHGRID1

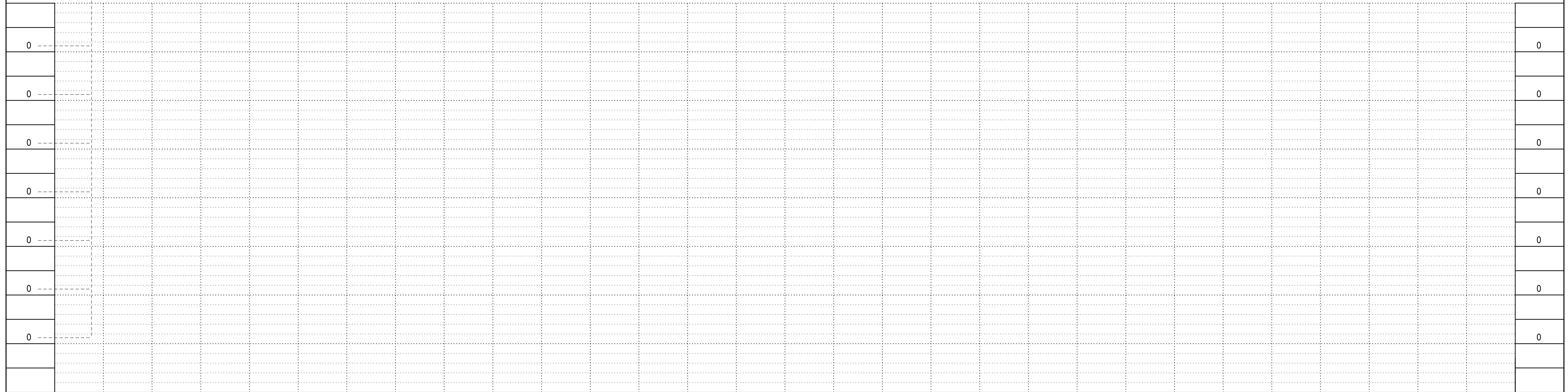

STATION 0+00 0+00 0+00 0+00 0+00 0+00

\$USERS
 \$TIMES
 \$DATE \$
 \$REV \$
 \$DATE \$
 \$BY \$
 \$APP \$
 \$SUB \$

REV.	DATE	ISSUED FOR	CH	IN
0	05-04-15	ISSUED FOR BID		

INFORMATION CONFIDENTIAL:
 All plans, drawings, specifications, and/or information furnished herewith shall remain the property of the Southern California Regional Rail Authority and shall be held confidential and shall not be used for any purpose not provided for in agreements with the Southern California Regional Rail Authority.

DESIGNED BY
D. ESIGNER
 DRAWN BY
D. RAFTER
 CHECKED BY
C. HECKER
 APPROVED BY
I. NCHARGE
 DATE
05-04-2016

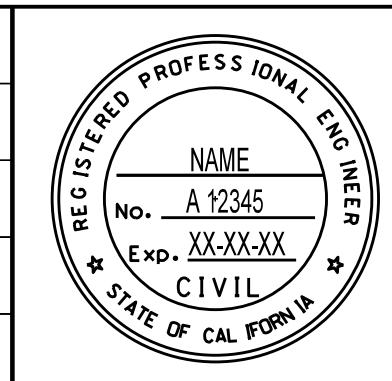

METROLINK COMMUTER RAIL SYSTEM
METROLINK ANAHEIM STATION
 MT1 TRACK PLAN AND
 PROFILE MAINLINE
 MT1 STA 3151+50 TO MT1 STA 3162+50

CONTRACT NO. C0000-00	
DRAWING NO. XX-000	
REVISION 0	SHEET NO. 000 OF 000
SCALE HORIZ 1"=20' VERT 1"=5'	

SUBMITTED: _____ PROJECT MANAGER
 APPROVED: _____



Appendix 16 – Sample Plan and Profile

AC=SCRRRA PGELEV
 TX=0.125, TW=0.10, FT=8, LV=17,
 CO=0 WT=1, Center Center Just.

AC=SCRRRA PHGRID2



STATION 0+00 0+00 0+00 0+00 0+00 0+00

\$DATE\$
 \$TIME\$
 \$REV\$
 \$DATE\$
 \$BY\$
 \$APP\$
 \$SUB\$

0	05-04-15	ISSUED FOR BID	CH	IN
REV.	DATE		BY	APP.

INFORMATION CONFIDENTIAL:
 All plans, drawings, specifications, and/or information furnished herewith shall remain the property of the Southern California Regional Rail Authority and shall be held confidential, and shall not be used for any purpose not provided for in agreements with the Southern California Regional Rail Authority.

DESIGNED BY
D. ESIGNER
 DRAWN BY
D. RAFTER
 CHECKED BY
C. HECKER
 APPROVED BY
I. NCHARGE
 DATE
05-04-2016

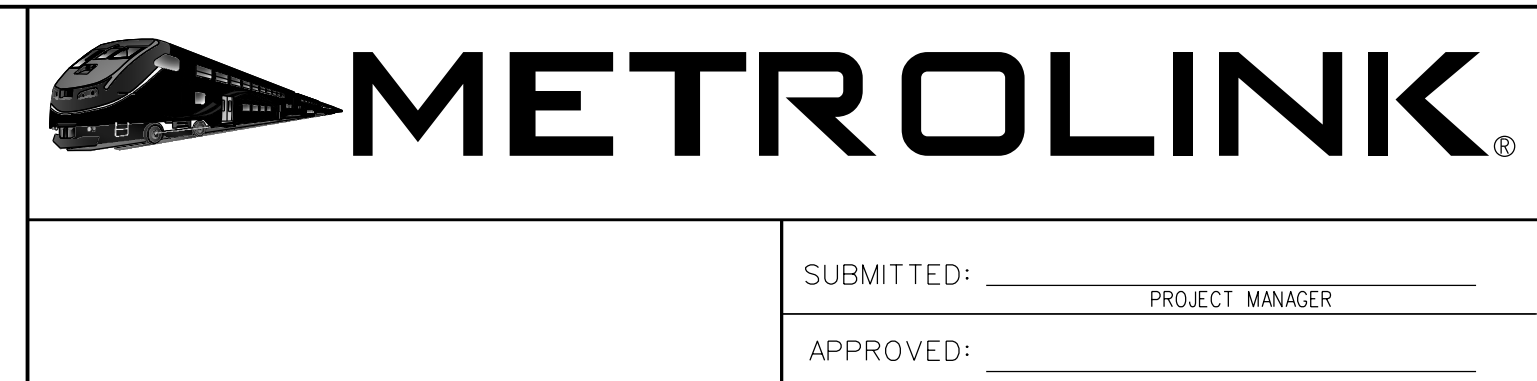
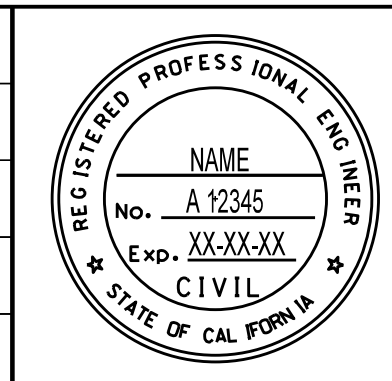

METROLINK COMMUTER RAIL SYSTEM
METROLINK ANAHEIM STATION
MT1 TRACK PLAN AND
PROFILE MAINLINE
MT1 STA 3151+50 TO MT1 STA 3162+50

CONTRACT NO. C0000-00	
DRAWING NO. XX-000	
REVISION 0	SHEET NO. 000 OF 000
SCALE HORIZ 1"=20' VERT 1"=5'	



Appendix 17 – Sample Full Profile

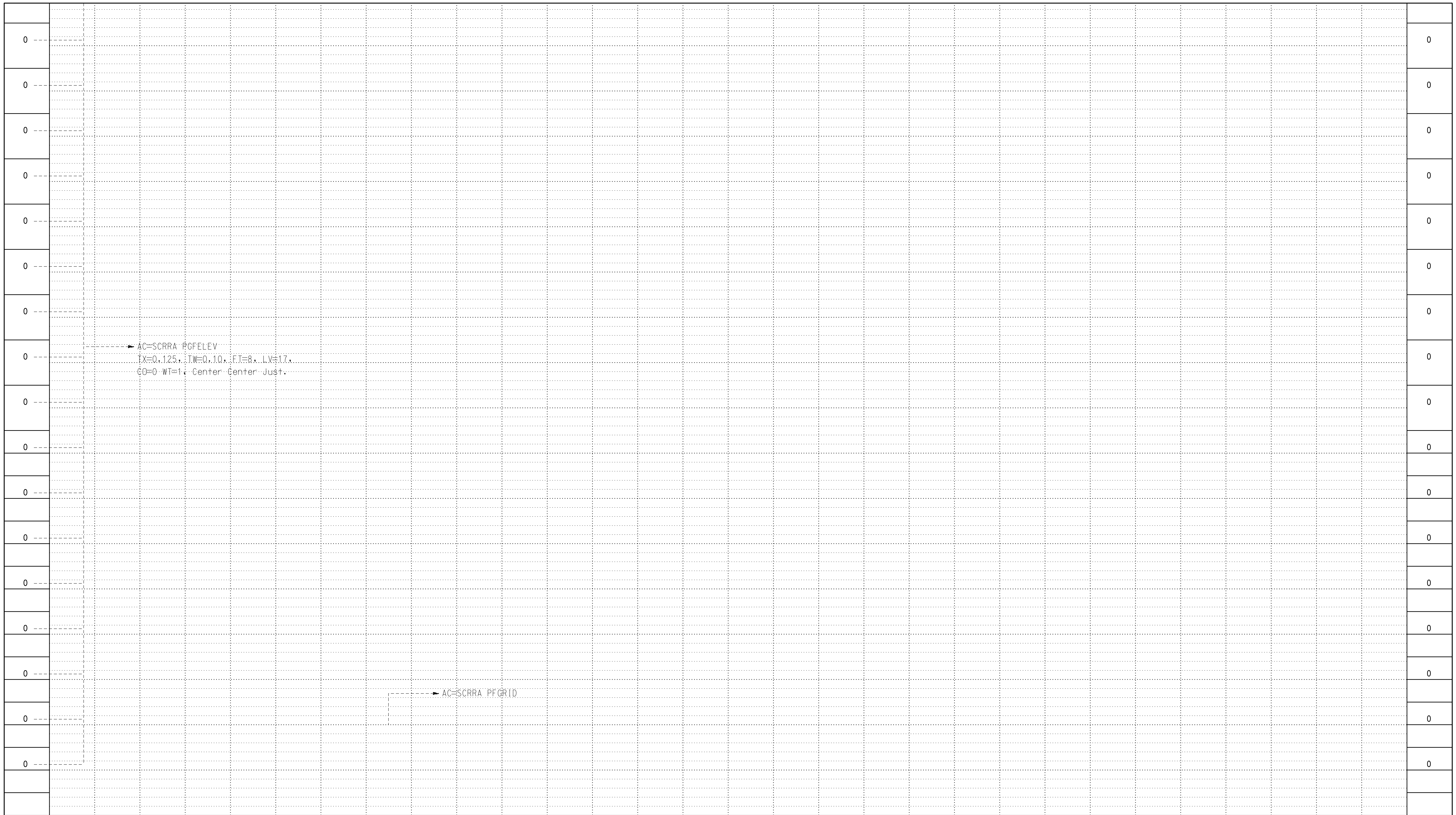

AC-SCRRRA PGFELEV
 TX=0.125, TW=0.10, FT=8, LV=17,
 CO=0 WT=1, Center Center Just.

AC-SCRRRA PGGRID

STATION 0+00 1+00 2+00 3+00 4+00 5+00

\$USERS
 \$TIMES
 \$DATE\$
 \$PLN\$
 \$PLOT\$
 \$PLOT\$

0	05-04-15	ISSUED FOR BID	CH	IN
REV.	DATE		BY	APP.

INFORMATION CONFIDENTIAL:
 All plans, drawings, specifications, and/or information furnished herewith shall remain the property of the Southern California Regional Rail Authority and shall not be used for any purpose not provided for in agreements with the Southern California Regional Rail Authority.

DESIGNED BY
D. ESIGNER
 DRAWN BY
D. RAFTER
 CHECKED BY
C. HECKER
 APPROVED BY
I. NCHARGE
 DATE
05-04-2016

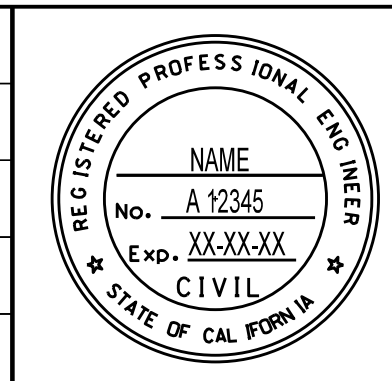

METROLINK COMMUTER RAIL SYSTEM
METROLINK ANAHEIM STATION
 MT2 TRACK
 PROFILE MAINLINE
 MT1 STA 3151+50 TO MT1 STA 3162+50

CONTRACT NO. C0000-00	
DRAWING NO. XX-000	
REVISION	SHEET NO.
0	000 OF 000
SCALE	HORIZ 1"=20' VERT 1"=5'

SUBMITTED: _____ PROJECT MANAGER
 APPROVED: _____



Appendix 18 – Sample Title page

SOUTHERN CALIFORNIA REGIONAL RAIL AUTHORITY

PROJECT NAME 1

PROJECT NAME 2

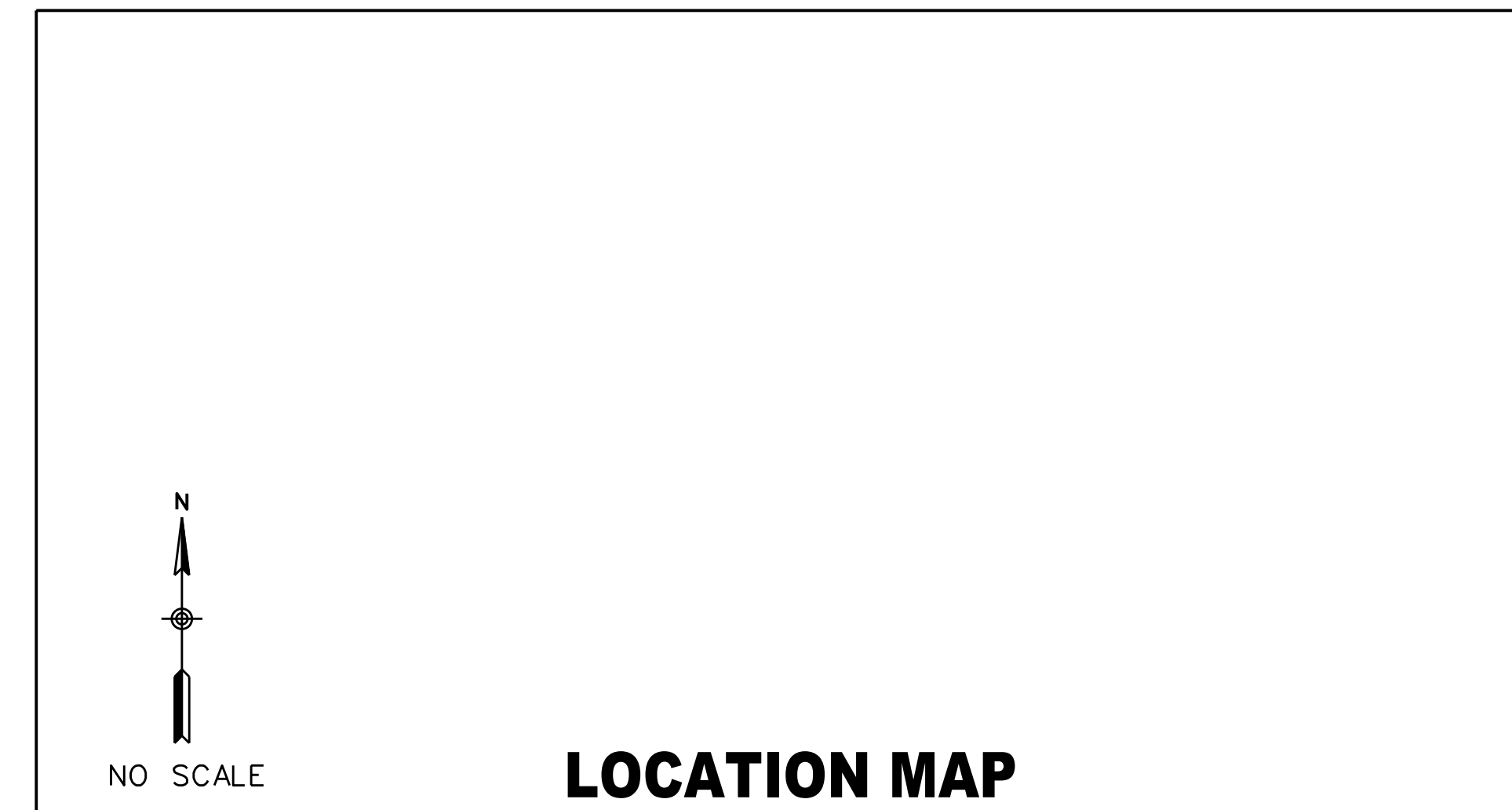
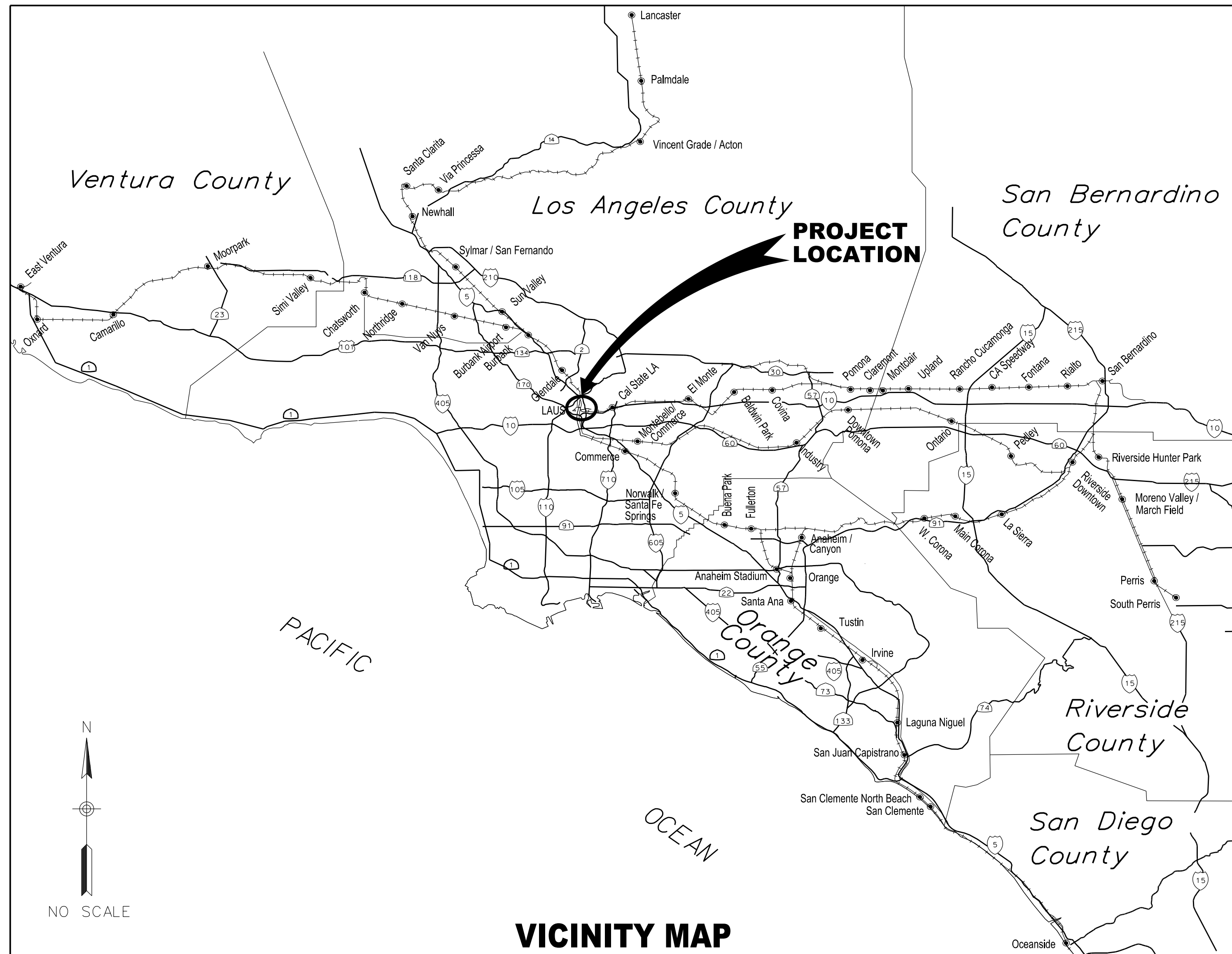

MONTH 01, YEAR

000% SUBMITTAL

SUBMITTAL STATUS



CONTRACT No. C-XXXX-XX

\$USERS
 \$TIMES
 \$DATES
 \$PLANS
 \$SPECS
 \$ELECTRICAL
 \$MECHANICAL

1 GEC CONSULTANT
 (COMPANY NAME AND LOGO)

APPROVED BY: _____ DATE: XX-XX-XX
 NAME, SCRRA

SUBMITTED BY: _____ DATE: XX-XX-XX
 NAME, PROJECT MANAGER

